

Standard **RCS4**  
Cleanroom Specification **RCS4CR**

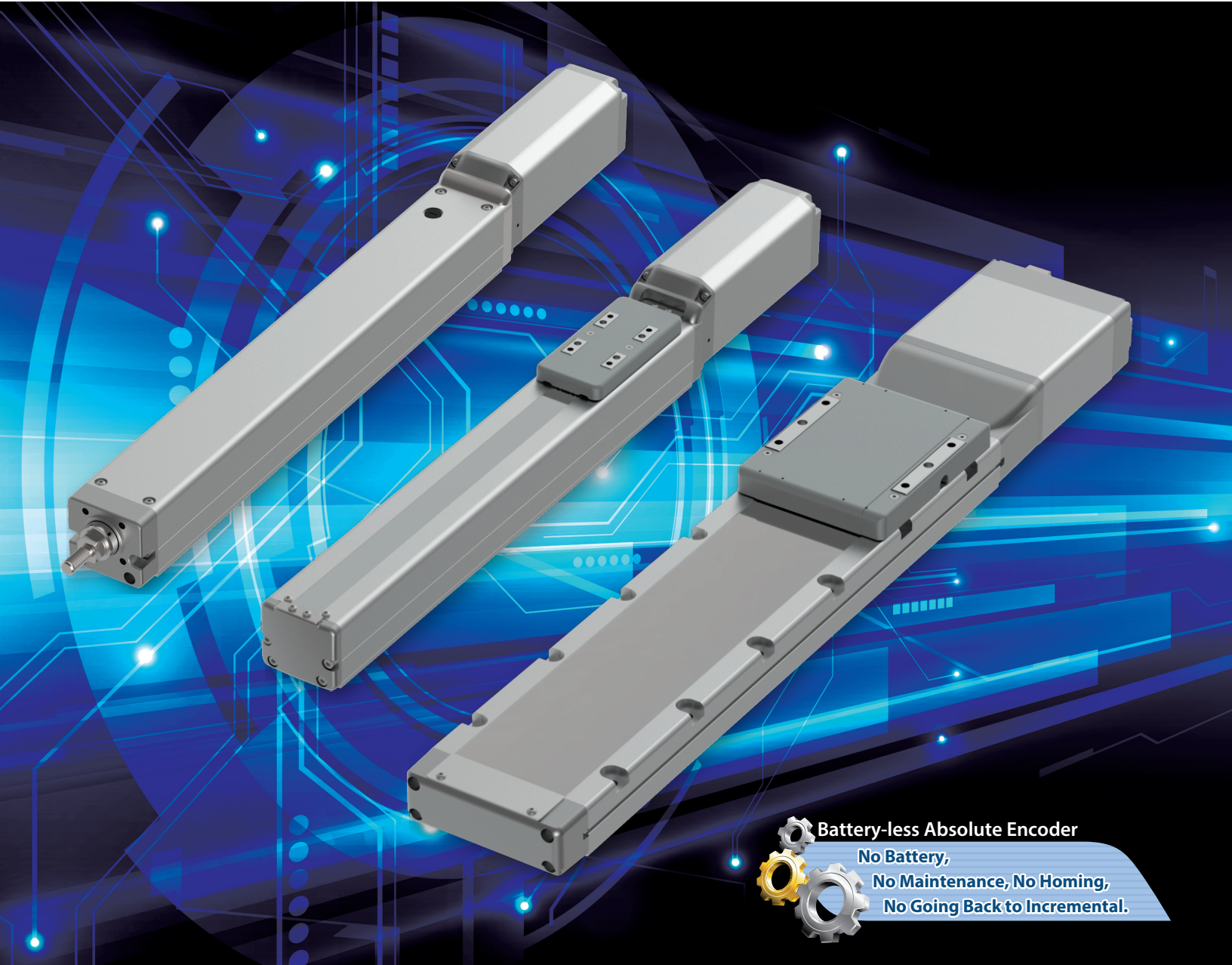

Battery-less Absolute Encoder  
No Battery,  
No Maintenance, No Homing,  
No Going Back to Incremental.

# RCS4 BENEFITS

## The advantages of using an absolute encoder

[For incremental encoder]

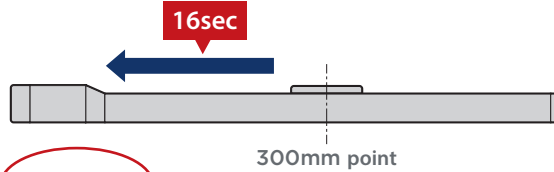

Hurry up!



It takes 16 seconds from the 300mm point until home return is completed.

## Home return not required

[For absolute encoder]

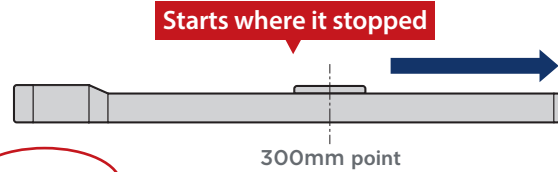

Smooth!



Since the position information is held by the battery, it is unnecessary to perform home return each time.

Normally, in emergency stops...

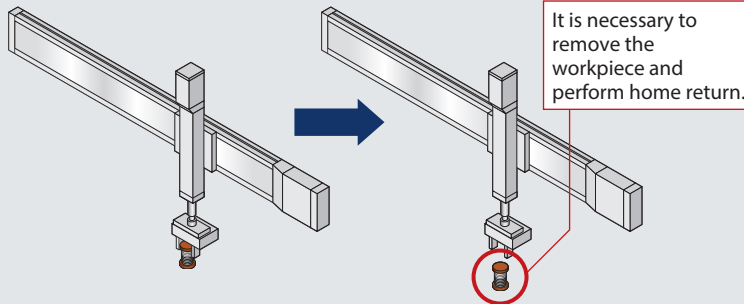

With absolute encoder

Since home return is unnecessary, there is no need to remove the workpiece and perform home return.

- MERIT 1** The recovery time after device shutdown can be shortened.
- MERIT 2** This reduces the production costs.



## The advantages of battery-less

## Battery replacement not required

**MERIT 1** The battery replacement processes and purchase costs can be reduced.

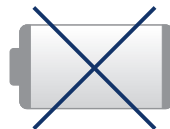

Replacement guidelines: Every 3 years

**MERIT 2** Battery-related trouble such as "voltage drop" will not occur.



The advantages of using an absolute encoder.



The advantages of battery-less



**Battery-less Absolute Encoder**

## An abundant lineup of 54 models



### Slider Type **SA**

The slider on the top of the body actuates. Since it uses a base integrated ball circulating type with a built-in linear guide, it will be able to deal with moments in the pitching, yawing, and rolling directions.

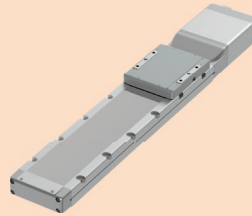

### Wide Slider Type **WSA**

The slider on the top of the body actuates. The ball circulating linear guide is built into the wide body. External guides are not required, even for applications with large overhangs.

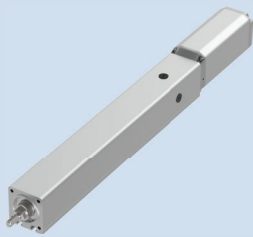

### Rod Type **RA**

The rod actuates in the same manner as the rod type air cylinder. This actuator type has no built-in linear guide and costs the least among the RCS4 rod types.



### Radial Cylinder **RRA**

The rod actuates in the same manner as the rod type air cylinder. Since ball circulating type linear guides are built in, it can take moment loads. External guides are not required.

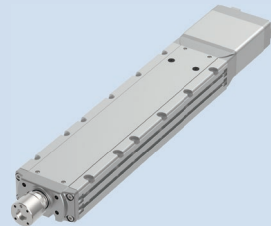

### Wide Radial Cylinder **WRA**

The rod actuates in the same manner as the rod type air cylinder. Due to a wide body and high rigidity rod, it can deal with up to four times the allowable torque on rod tip compared to a radial cylinder.



### Table Type **TA**

The table actuates on top of the main body. A ball circulating type linear guide is built into the table. Double block can be selected as an option, so that the two guide blocks increase the allowable dynamic moment.

Now hear this!

### Radial Cylinder **RRA**

You may not believe it, but...  
**A guide is not required!**

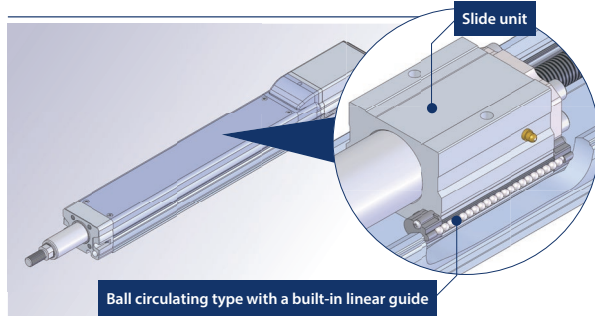

Since ball circulating type linear guides are built into the rod type body, it can take radial loads and moment loads. The equipment will be compact since an external guide is unnecessary.

### Wide Slider Type **WSA**

Since it uses a built-in ball circulating type with a built-in linear guide inside its wide body, it will be able to deal with high load moments in the pitching, yawing, and rolling directions. Since it is flat, it is ideal when the space in the height direction is limited.

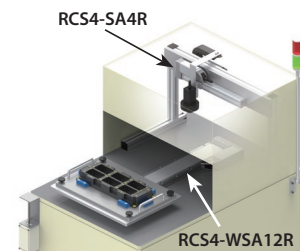

#### Device using an air cylinder

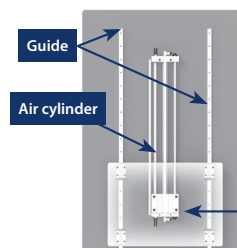

#### Device using ROBO Cylinder

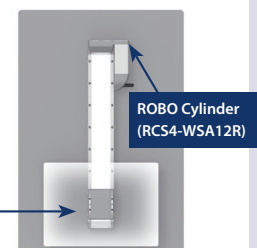

# Product Lineup

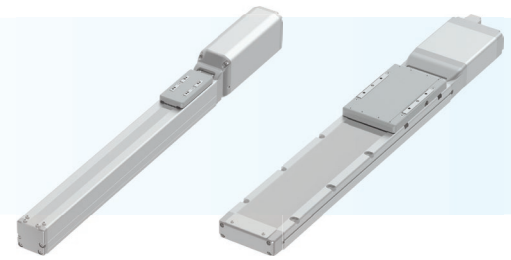

## Slider Type: SA

Motor	Type	External view	Body width (mm)	Motor wattage (W)	Lead (mm)	Positioning repeatability (mm)	Stroke (mm)	Max speed (mm/s)	Rated thrust (N)	Max. payload (kg)		Reference page
										Horizontal	Vertical	
Coupled Motor	SA4C		40mm	60	16	±0.01 [±0.005]	50~500 (50st increments)	960	53	10	3	P11
					600			85	14	5		
					300			170	17	8		
	SA6C		60mm	100	2.5	±0.01 [±0.005]	50~800 (50st increments)	150	340	20	12	P13
					1600			57	11	3.5		
					1200			85	18	6		
					720			142	30	11		
					360			283	45	15		
					180			566	45	15		
	SA7C		70mm	200	36	±0.01 [±0.005]	50~800 (50st increments)	1800	95	7	4	P15
					24			1500	142	30	7	
					16			1000	214	40	12	
SA8C		90mm	400	8	±0.01 [±0.005]	50~1100 (50st increments)	500	427	45	20	P17	
				4			240	855	50	25		
				48			2200	141	8	-		
				30			1800	226	30	12		
				20			1200	339	60	20		
Side-mounted Motor	SA4R		40mm	60	16	±0.01	50~500 (50st increments)	960	53	10	2.5	P19
					600			85	14	4.5		
					300			170	17	8		
	SA6R		60mm	100	2.5	±0.01	50~800 (50st increments)	150	340	20	12	P21
					1600			57	11	3		
					1200			85	18	5		
					720			142	30	9		
					360			283	45	15		
					180			566	45	15		
	SA7R		70mm	200	36	±0.01	50~800 (50st increments)	1800	95	7	4	P23
					24			1500	142	30	6	
					16			1000	214	38	12	
SA8R		90mm	400	8	±0.01	50~1100 (50st increments)	500	427	45	18	P25	
				4			240	855	50	25		
				48			2100	141	8	-		
				30			1800	226	30	12		
				20			1200	339	60	20		
				10			600	678	80	35		
				5			300	1357	90	45		

Values in [ ] are for high-precision specification

## Wide Slider Type: WSA

Motor	Type	External view	Body width (mm)	Motor wattage (W)	Lead (mm)	Positioning repeatability (mm)	Stroke (mm)	Max speed (mm/s)	Rated thrust (N)	Max. payload (kg)		Reference page
										Horizontal	Vertical	
Coupled Motor	WSA10C		100mm	60	16	±0.01 [±0.005]	50~500 (50st increments)	960	53	7	-	P27
					600			85	16	3		
					300			170	27	5		
	WSA12C		120mm	100	2.5	±0.01 [±0.005]	50~800 (50st increments)	150	340	40	10	P29
					1600			57	5	-		
					1200			85	15	3		
					720			142	25	8		
					360			283	45	15		
					180			566	55	15		
	WSA14C		140mm	200	36	±0.01 [±0.005]	50~800 (50st increments)	1800	95	7	-	P31
					24			1440	142	20	2.5	
					16			960	214	45	8	
WSA16C		160mm	400	8	±0.01 [±0.005]	50~1100 (50st increments)	480	427	65	10	P33	
				4			240	855	80	25		
				30			1800	226	30	12		
				20			1200	339	60	20		
				10			600	678	80	35		
Side-mounted Motor	WSA10R		100mm	60	16	±0.01	50~500 (50st increments)	960	53	7	-	P35
					600			85	16	3		
					300			170	27	5		
	WSA12R		120mm	100	2.5	±0.01	50~800 (50st increments)	150	340	40	10	P37
					1600			57	5	-		
					1200			85	13	3		
					720			142	23	8		
					360			283	43	15		
					180			566	55	15		
	WSA14R		140mm	200	36	±0.01	50~800 (50st increments)	1710	95	7	-	P39
					24			1440	142	20	2.5	
					16			960	214	45	8	
WSA16R		160mm	400	8	±0.01	50~1100 (50st increments)	480	427	65	10	P41	
				4			240	855	75	25		
				30			1800	226	30	12		
				20			1200	339	60	18		
				10			600	678	80	35		
				5			300	1357	100	50		

Values in [ ] are for high-precision specification

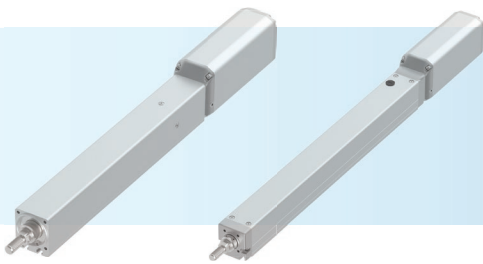

## Rod Type: RA

Motor	Type	External view	Body width (mm)	Motor wattage (W)	Lead (mm)	Positioning repeatability (mm)	Stroke (mm)	Max speed (mm/s)	Rated thrust (N)	Max. payload (kg)		Reference page
										Horizontal	Vertical	
Coupled Motor	RA4C		40mm	60	16	±0.01	50~200 (50st increments)	800	53	8	2	P43
					10			500	85	18	4	
					5			250	170	30	6	
					2.5			125	340	40	10	
	RA6C		60mm	100	20	±0.01	50~300 (50st increments)	1000	85	15	4	P45
					12			600	142	25	10	
					6			300	283	50	20	
					3			150	566	60	20	
	RA7C		70mm	200	24	±0.01	50~300 (50st increments)	1200	142	20	6	P47
					16			800	214	45	12	
					8			400	427	60	25	
					4			200	855	80	35	
RA8C		90mm	400	20	±0.01	50~300 (50st increments)	1000	399	60	20	P49	
				10			500	678	80	40		
				5			250	1357	100	72		
Side-mounted Motor	RA4R		40mm	60	16	±0.01	50~200 (50st increments)	800	53	8	2	P51
					10			500	85	18	4	
					5			250	170	30	6	
					2.5			125	340	40	10	
	RA6R		60mm	100	20	±0.01	50~300 (50st increments)	1000	85	15	4	P53
					12			600	142	25	9	
					6			300	283	50	19	
					3			150	566	60	20	
	RA7R		70mm	200	24	±0.01	50~300 (50st increments)	1200	142	20	6	P55
					16			800	214	45	12	
					8			400	427	60	25	
					4			200	855	80	35	
RA8R		90mm	400	20	±0.01	50~300 (50st increments)	1000	339	60	20	P57	
				10			500	678	80	40		
				5			250	1357	100	72		

## Radial Cylinder: RRA

Motor	Type	External view	Body width (mm)	Motor wattage (W)	Lead (mm)	Positioning repeatability (mm)	Stroke (mm)	Max speed (mm/s)	Rated thrust (N)	Max. payload (kg)		Reference page
										Horizontal	Vertical	
Coupled Motor	RRA4C		40mm	60	16	±0.01	60~410 (50st increments)	960	53	8	2	P59
					10			600	85	18	4	
					5			300	170	30	6	
					2.5			150	340	40	10	
	RRA6C		60mm	100	20	±0.01	65~415 (50st increments)	1200	85	15	4	P61
					12			720	142	25	10	
					6			360	283	50	20	
					3			180	566	60	20	
	RRA7C		70mm	200	24	±0.01	70~520 (50st increments)	1440	142	20	6	P63
					16			960	214	45	12	
					8			480	427	60	25	
					4			240	855	80	35	
RRA8C		90mm	400	30	±0.01	50~700 (50st increments)	1500	226	30	8	P65	
				20			1100	339	60	20		
				10			550	678	80	40		
				5			275	1357	100	72		
Side-mounted Motor	RRA4R		40mm	60	16	±0.01	60~410 (50st increments)	960	53	8	2	P67
					10			600	85	18	4	
					5			300	170	30	6	
					2.5			150	340	40	10	
	RRA6R		60mm	100	20	±0.01	65~415 (50st increments)	1200	85	15	4	P69
					12			720	142	25	9	
					6			360	283	50	19	
					3			180	566	60	20	
	RRA7R		70mm	200	24	±0.01	70~520 (50st increments)	1440	142	20	6	P71
					16			960	214	45	12	
					8			480	427	60	25	
					4			240	855	80	35	
RRA8R		90mm	400	30	±0.01	50~700 (50st increments)	1300	226	30	8	P73	
				20			1000	339	60	17		
				10			550	678	80	34		
				5			275	1357	100	72		

# Product Lineup

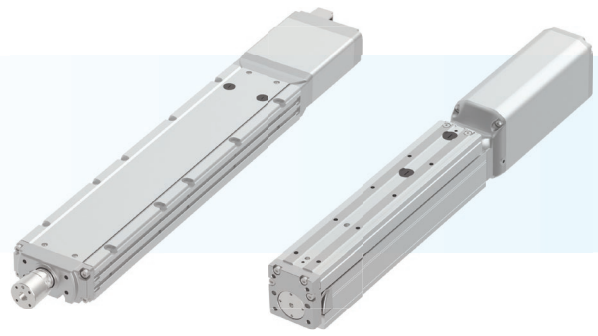

## Wide Radial Cylinder: WRA

Motor	Type	External view	Body width (mm)	Motor wattage (W)	Lead (mm)	Positioning repeatability (mm)	Stroke (mm)	Max speed (mm/s)	Rated thrust (N)	Max. payload (kg)		Reference page
										Horizontal	Vertical	
Coupled Motor	WRA10C		100mm	60	16	±0.01	50~500 (50st increments)	800	53	5	—	P75
					10			600	85	16	3	
					5			300	170	25	5	
					2.5			150	340	40	10	
	WRA12C		120mm	100	20	±0.01	50~500 (50st increments)	1000	85	12	2	P77
					12			720	142	25	6	
					6			360	283	40	15	
					3			180	566	60	20	
	WRA14C		140mm	200	24	±0.01	50~600 (50st increments)	1200	142	25	3	P79
					16			800	214	50	8	
					8			480	427	65	20	
					4			240	855	85	30	
WRA16C		160mm	400	30	±0.01	50~800 (50st increments)	1300	226	30	6	P81	
				20			1000	339	60	12		
				10			500	678	80	35		
				5			250	1357	100	50		
Side-mounted Motor	WRA10R		100mm	60	16	±0.01	50~500 (50st increments)	800	53	5	—	P83
					10			600	85	13	2.5	
					5			300	170	25	5	
					2.5			150	340	40	10	
	WRA12R		120mm	100	20	±0.01	50~500 (50st increments)	1000	85	12	2	P85
					12			720	142	25	6	
					6			360	283	40	15	
					3			180	566	60	20	
	WRA14R		140mm	200	24	±0.01	50~600 (50st increments)	1200	142	25	3	P87
					16			800	214	50	8	
					8			480	427	65	20	
					4			240	855	85	30	
WRA16R		160mm	400	30	±0.01	50~800 (50st increments)	1300	226	30	6	P89	
				20			1000	339	60	12		
				10			500	678	80	35		
				5			250	1357	100	50		

## Table Type: TA

Motor	Type	External view	Body width (mm)	Motor wattage (W)	Lead (mm)	Positioning repeatability (mm)	Stroke (mm)	Max speed (mm/s)	Rated thrust (N)	Max. payload (kg)		Reference page
										Horizontal	Vertical	
Coupled Motor	TA4C		40mm	60	16*	±0.01	Single Block 25~150 (25st increments) Double Block 40~90 (25st increments) 140,190,240	900[-]	53[-]	4[-]	1.5[-]	P91 P93
					10			600	85	5[8]	3	
					5			300	170	5[10]	6	
					2.5			150	340	5[10]	9	
	TA6C		60mm	100	20*	±0.01	Single Block 25~200 (25st increments) Double Block 45~120 (25st increments) 170~320 (50st increments)	1100[-]	85[-]	8[-]	4[-]	P95 P97
					12			720	142	8[14]	6	
					6			360	283	8[20]	10	
					3			180	566	10[20]	12	
	TA7C		70mm	200	24*	±0.01	Single Block 25~200 (25mm increments) 250,300 Double Block 40~90 (25mm increments) 140~390 (50mm increments)	1300[-]	142[-]	12[-]	5[-]	P99 P101
					16			960	214	15[25]	10[8]	
					8			480	427	15[30]	18	
					4			240	855	15[30]	20[24]	
Side-mounted Motor	TA4R		40mm	60	16*	±0.01	Single Block 25~150 (25st increments) Double Block 40~90 (25st increments) 140,190,240	800[-]	53[-]	4[-]	1.5[-]	P103 P105
					10			600	85	5[8]	3	
					5			300	170	5[10]	6	
					2.5			150	340	5[10]	9	
	TA6R		60mm	100	20*	±0.01	Single Block 25~200 (25st increments) Double Block 45~120 (25st increments) 170~320 (50st increments)	1000[-]	85[-]	8[-]	4[-]	P107 P109
					12			720	142	8[14]	6	
					6			360	283	8[20]	10	
					3			180	566	10[20]	10[12]	
	TA7R		70mm	200	24*	±0.01	Single Block 25~200 (25mm increments) 250,300 Double Block 40~90 (25mm increments) 140~390 (50mm increments)	1200[-]	142[-]	12[-]	5[-]	P111 P113
					16			960	214	15[25]	10[8]	
					8			480	427	15[30]	18	
					4			240	855	15[30]	20[24]	

\* Single Block (SB) specification only. Values in [ ] are for double block specification

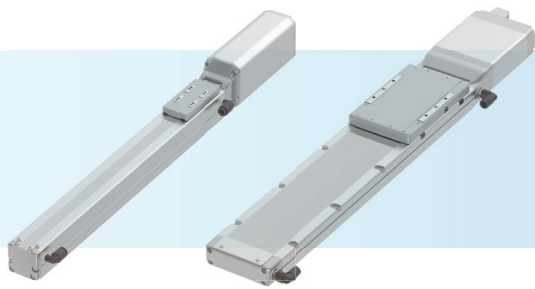

## Slider Type SA <Cleanroom Specification>

Motor	Type	External view	Body width (mm)	Motor wattage (W)	Lead (mm)	Positioning repeatability (mm)	Stroke (mm)	Max Speed (mm/s)	Rated thrust (N)	Max. payload (kg)	Cleanliness	Reference page	
										Horizontal Vertical			
Coupled Motor	SA4C		40mm	60	16	±0.01 [±0.005]	50~500 (50st increments)	960	53	10	3	Class 10 (Fed.Std.209D Standard)  Class 2.5 or equivalent (ISO 14644-1 Standard)	p115
					10			600	85	14	5		
					5			300	170	17	8		
					2.5			150	340	20	12		
	SA6C		60mm	100	20	±0.01 [±0.005]	50~800 (50st increments)	1200	85	18	6		p117
					12			720	142	30	11		
					6			360	283	45	15		
	SA7C		70mm	200	24	±0.01 [±0.005]	50~800 (50st increments)	1500	142	30	7		p119
					16			1000	214	40	12		
					8			500	427	45	20		
					4			240	855	50	25		
	SA8C		90mm	400	20	±0.01 [±0.005]	50~1100 (50st increments)	1200	339	60	20		p121
					10			600	678	80	35		
					5			300	1357	90	45		

Values in [ ] are for high-precision specification

## Wide Slider Type WSA <Cleanroom Specification>

Motor	Type	External view	Body width (mm)	Motor wattage (W)	Lead (mm)	Positioning repeatability (mm)	Stroke (mm)	Max Speed (mm/s)	Rated thrust (N)	Max. payload (kg)	Cleanliness	Reference page	
										Horizontal Vertical			
Coupled Motor	WSA10C		100mm	60	16	±0.01 [±0.005]	50~500 (50st increments)	960	53	7	-	Class 10 (Fed.Std.209D Standard)  Class 2.5 or equivalent (ISO 14644-1 Standard)	p123
					10			600	85	16	3		
					5			300	170	27	5		
					2.5			150	340	40	10		
	WSA12C		120mm	100	20	±0.01 [±0.005]	50~800 (50st increments)	1200	85	15	3		p125
					12			720	142	25	8		
					6			360	283	45	15		
	WSA14C		140mm	200	24	±0.01 [±0.005]	50~800 (50st increments)	1440	142	20	2.5		p127
					16			960	214	45	8		
					8			480	427	65	10		
					4			240	855	80	25		
	WSA16C		160mm	400	20	±0.01 [±0.005]	50~1100 (50st increments)	1200	339	60	20		p129
					10			600	678	80	35		
					5			300	1357	100	50		

Values in [ ] are for high-precision specification

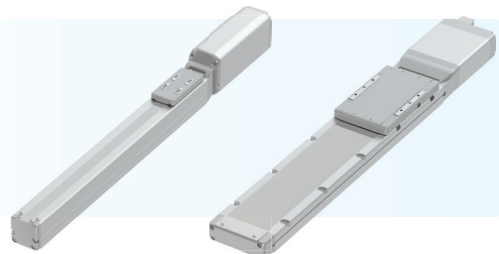

# Model Specification Number

## Slider Type: SA

**RCS4** — [ ] — **WA** — [ ] — [ ] — [ ] — [ ] — [ ] — [ ]

Series      Type      Encoder Type      Motor Type      Ball Screw Lead      Stroke      Applicable Controllers      Cable Length      Options

<b>SA4C</b>	Body width 40mm Coupled motor type	<b>WA</b> Battery-less Absolute	<b>60</b> 60W <b>100</b> 100W <b>200</b> 200W <b>400</b> 400W	<b>2.5</b> 2.5mm <b>3</b> 3mm <b>4</b> 4mm <b>5</b> 5mm <b>6</b> 6mm <b>8</b> 8mm <b>10</b> 10mm <b>12</b> 12mm <b>16</b> 16mm <b>20</b> 20mm <b>24</b> 24mm <b>30</b> 30mm <b>36</b> 36mm <b>48</b> 48mm	<b>50</b> 50mm ? ? <b>1100</b> 1100mm (50mm increments)	<b>T2</b> SCON MSCON SSEL XSEL-P/Q XSEL-RA/SA	[ ] [ ] [ ] [ ] [ ] [ ]	<table border="1"> <tr><td><b>N</b></td><td>None</td></tr> <tr><td><b>P</b></td><td>1m</td></tr> <tr><td><b>S</b></td><td>3m</td></tr> <tr><td><b>M</b></td><td>5m</td></tr> <tr><td><b>X</b> <input type="checkbox"/></td><td>Specified length (Standard cable)</td></tr> <tr><td><b>R</b> <input type="checkbox"/></td><td>Robot cable</td></tr> </table>	<b>N</b>	None	<b>P</b>	1m	<b>S</b>	3m	<b>M</b>	5m	<b>X</b> <input type="checkbox"/>	Specified length (Standard cable)	<b>R</b> <input type="checkbox"/>	Robot cable
<b>N</b>	None																			
<b>P</b>	1m																			
<b>S</b>	3m																			
<b>M</b>	5m																			
<b>X</b> <input type="checkbox"/>	Specified length (Standard cable)																			
<b>R</b> <input type="checkbox"/>	Robot cable																			
<b>SA6C</b>	Body width 60mm Coupled motor type																			
<b>SA7C</b>	Body width 70mm Coupled motor type																			
<b>SA8C</b>	Body width 90mm Coupled motor type																			
<b>SA4R</b>	Body width 40mm Side-mounted motor type																			
<b>SA6R</b>	Body width 60mm Side-mounted motor type																			
<b>SA7R</b>	Body width 70mm Side-mounted motor type																			
<b>SA8R</b>	Body width 90mm Side-mounted motor type																			

\*The type of motor, ball screw lead, stroke, and selection options vary depending on the actuator type. Please refer to the pages of each type for details.

## Wide Slider Type: WSA

**RCS4** — [ ] — **WA** — [ ] — [ ] — [ ] — [ ] — [ ] — [ ]

Series      Type      Encoder Type      Motor Type      Ball Screw Lead      Stroke      Applicable Controllers      Cable Length      Options

<b>WSA10C</b>	Body width 100mm Coupled motor type	<b>WA</b> Battery-less Absolute	<b>60</b> 60W <b>100</b> 100W <b>200</b> 200W <b>400</b> 400W	<b>2.5</b> 2.5mm <b>3</b> 3mm <b>4</b> 4mm <b>5</b> 5mm <b>6</b> 6mm <b>8</b> 8mm <b>10</b> 10mm <b>12</b> 12mm <b>16</b> 16mm <b>20</b> 20mm <b>24</b> 24mm <b>30</b> 30mm <b>36</b> 36mm	<b>50</b> 50mm ? ? <b>1100</b> 1100mm (50mm increments)	<b>T2</b> SCON MSCON SSEL XSEL-P/Q XSEL-RA/SA	[ ] [ ] [ ] [ ] [ ] [ ]	<table border="1"> <tr><td><b>N</b></td><td>None</td></tr> <tr><td><b>P</b></td><td>1m</td></tr> <tr><td><b>S</b></td><td>3m</td></tr> <tr><td><b>M</b></td><td>5m</td></tr> <tr><td><b>X</b> <input type="checkbox"/></td><td>Specified length (Standard cable)</td></tr> <tr><td><b>R</b> <input type="checkbox"/></td><td>Robot cable</td></tr> </table>	<b>N</b>	None	<b>P</b>	1m	<b>S</b>	3m	<b>M</b>	5m	<b>X</b> <input type="checkbox"/>	Specified length (Standard cable)	<b>R</b> <input type="checkbox"/>	Robot cable
<b>N</b>	None																			
<b>P</b>	1m																			
<b>S</b>	3m																			
<b>M</b>	5m																			
<b>X</b> <input type="checkbox"/>	Specified length (Standard cable)																			
<b>R</b> <input type="checkbox"/>	Robot cable																			
<b>WSA12C</b>	Body width 120mm Coupled motor type																			
<b>WSA14C</b>	Body width 140mm Coupled motor type																			
<b>WSA16C</b>	Body width 160mm Coupled motor type																			
<b>WSA10R</b>	Body width 100mm Side-mounted motor type																			
<b>WSA12R</b>	Body width 120mm Side-mounted motor type																			
<b>WSA14R</b>	Body width 140mm Side-mounted motor type																			
<b>WSA16R</b>	Body width 160mm Side-mounted motor type																			

\*The type of motor, ball screw lead, stroke, and selection options vary depending on the actuator type. Please refer to the pages of each type for details.



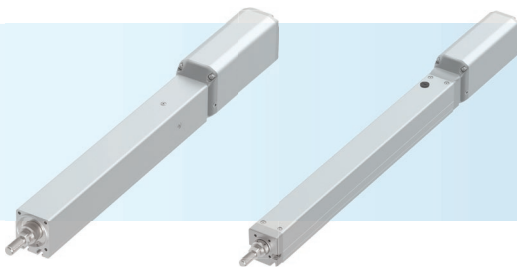

# Rod Type: RA

**RCS4** — [ ] — **WA** — [ ] — [ ] — [ ] — [ ] — [ ] — [ ]

Series      Type      Encoder Type      Motor Type      Ball Screw Lead      Stroke      Applicable Controllers      Cable Length      Options

<b>WA</b>	Battery-less Absolute
-----------	-----------------------

<b>60</b>	60W
<b>100</b>	100W
<b>200</b>	200W
<b>400</b>	400W

<b>50</b>	50mm
<i>z</i>	<i>z</i>
<b>300</b>	300mm

(50mm increments)

<b>2.5</b>	2.5mm
<b>3</b>	3mm
<b>4</b>	4mm
<b>5</b>	5mm
<b>6</b>	6mm
<b>8</b>	8mm
<b>10</b>	10mm
<b>12</b>	12mm
<b>16</b>	16mm
<b>20</b>	20mm
<b>24</b>	24mm

<b>T2</b>	SCON MSCON SSEL XSEL-P/Q XSEL-RA/SA
-----------	---

<b>N</b>	None
<b>P</b>	1m
<b>S</b>	3m
<b>M</b>	5m
<b>X</b> □□	Specified length (Standard cable)
<b>R</b> □□	Robot cable

<b>RA4C</b>	Body width 40mm Coupled motor type
<b>RA6C</b>	Body width 60mm Coupled motor type
<b>RA7C</b>	Body width 70mm Coupled motor type
<b>RA8C</b>	Body width 90mm Coupled motor type
<b>RA4R</b>	Body width 40mm Side-mounted motor type
<b>RA6R</b>	Body width 60mm Side-mounted motor type
<b>RA7R</b>	Body width 70mm Side-mounted motor type
<b>RA8R</b>	Body width 90mm Side-mounted motor type

<b>B</b>	Brake
<b>CJT</b>	Cable exit direction (Top)
<b>CJR</b>	Cable exit direction (Right)
<b>CJL</b>	Cable exit direction (Left)
<b>CJO</b>	Cable exit direction (Outside)
<b>CJB</b>	Cable exit direction (Bottom)
<b>FL</b>	Flange
<b>FT</b>	Foot bracket
<b>ML</b>	Motor side-mounted to left (standard)
<b>MR</b>	Motor side-mounted to right
<b>NFA</b>	Tip adapter (Internal thread)
<b>NM</b>	Non-motor End Specification
<b>NTB</b>	T-slot nut bar
<b>RP</b>	Back mounting plate

\*The type of motor, ball screw lead, stroke, and selection options vary depending on the actuator type. Please refer to the pages of each type for details.

# Radial Cylinder: RRA

**RCS4** — [ ] — **WA** — [ ] — [ ] — [ ] — [ ] — [ ] — [ ]

Series      Type      Encoder Type      Motor Type      Ball Screw Lead      Stroke      Applicable Controllers      Cable Length      Options

<b>WA</b>	Battery-less Absolute
-----------	-----------------------

<b>60</b>	60W
<b>100</b>	100W
<b>200</b>	200W
<b>400</b>	400W

<b>60</b>	60mm
<i>z</i>	<i>z</i>
<b>700</b>	700mm

(50mm increments)

<b>2.5</b>	2.5mm
<b>3</b>	3mm
<b>4</b>	4mm
<b>5</b>	5mm
<b>6</b>	6mm
<b>8</b>	8mm
<b>10</b>	10mm
<b>12</b>	12mm
<b>16</b>	16mm
<b>20</b>	20mm
<b>24</b>	24mm
<b>30</b>	30mm

<b>T2</b>	SCON MSCON SSEL XSEL-P/Q XSEL-RA/SA
-----------	---

<b>N</b>	None
<b>P</b>	1m
<b>S</b>	3m
<b>M</b>	5m
<b>X</b> □□	Specified length (Standard cable)
<b>R</b> □□	Robot cable

<b>RRA4C</b>	Body width 40mm Coupled motor type
<b>RRA6C</b>	Body width 60mm Coupled motor type
<b>RRA7C</b>	Body width 70mm Coupled motor type
<b>RRA8C</b>	Body width 90mm Coupled motor type
<b>RRA4R</b>	Body width 40mm Side-mounted motor type
<b>RRA6R</b>	Body width 60mm Side-mounted motor type
<b>RRA7R</b>	Body width 70mm Side-mounted motor type
<b>RRA8R</b>	Body width 90mm Side-mounted motor type

<b>B</b>	Brake
<b>CJT</b>	Cable exit direction (Top)
<b>CJR</b>	Cable exit direction (Right)
<b>CJL</b>	Cable exit direction (Left)
<b>CJO</b>	Cable exit direction (Outside)
<b>CJB</b>	Cable exit direction (Bottom)
<b>FL</b>	Flange
<b>FFA</b>	Tip adapter (Flange)
<b>NFA</b>	Tip adapter (Internal thread)
<b>KFA</b>	Tip adapter (Keyway)
<b>ML</b>	Motor side-mounted to left (standard)
<b>MR</b>	Motor side-mounted to right
<b>NM</b>	Non-motor End Specification
<b>RP</b>	Back mounting plate

\*The type of motor, ball screw lead, stroke, and selection options vary depending on the actuator type. Please refer to the pages of each type for details.

# Model Number

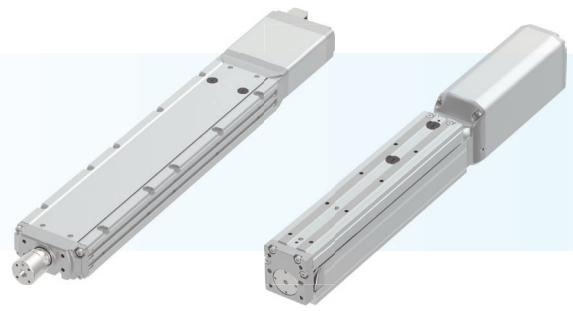

## Wide Radial Cylinder: WRA

**RCS4** — [ ] — **WA** — [ ] — [ ] — [ ] — [ ] — [ ] — [ ] — [ ]

Series      Type      Encoder Type      Motor Type      Ball Screw Lead      Stroke      Applicable Controllers      Cable Length      Options

Series	Type	Encoder Type	Motor Type	Ball Screw Lead	Stroke	Applicable Controllers	Cable Length	Options
<b>WRA10C</b>	Body width 100mm Coupled motor type	<b>WA</b> Battery-less Absolute	<b>60</b> 60W <b>100</b> 100W <b>200</b> 200W <b>400</b> 400W	<b>2.5</b> 2.5mm <b>3</b> 3mm <b>4</b> 4mm <b>5</b> 5mm <b>6</b> 6mm <b>8</b> 8mm <b>10</b> 10mm <b>12</b> 12mm <b>16</b> 16mm <b>20</b> 20mm <b>24</b> 24mm <b>30</b> 30mm	<b>50</b> 50mm ? ? <b>800</b> 800mm (50mm increments)	<b>T2</b> SCON MSCON SSEL XSEL-P/Q XSEL-RA/SA	<b>N</b> None <b>P</b> 1m <b>S</b> 3m <b>M</b> 5m <b>X</b> □□ Specified length (Standard cable) <b>R</b> □□ Robot cable	<b>B</b> Brake <b>CJT</b> Cable exit direction (Top) <b>CJR</b> Cable exit direction (Right) <b>CJL</b> Cable exit direction (Left) <b>CJO</b> Cable exit direction (Outside) <b>CJB</b> Cable exit direction (Bottom) <b>FL</b> Flange <b>ML</b> Motor side-mounted to left (standard) <b>MR</b> Motor side-mounted to right <b>NM</b> Non-motor End Specification <b>NTBL</b> T-slot nut bar (Left) <b>NTBR</b> T-slot nut bar (Right)

\*The type of motor, ball screw lead, stroke, and selection options vary depending on the actuator type. Please refer to the pages of each type for details.

## Table Type: TA

**RCS4** — [ ] — **WA** — [ ] — [ ] — [ ] — [ ] — [ ] — [ ] — [ ]

Series      Type      Encoder Type      Motor Type      Ball Screw Lead      Stroke      Applicable Controllers      Cable Length      Options

Series	Type	Encoder Type	Motor Type	Ball Screw Lead	Stroke	Applicable Controllers	Cable Length	Options
<b>TA4C</b>	Body width 40mm Coupled motor type	<b>WA</b> Battery-less Absolute	<b>60</b> 60W <b>100</b> 100W <b>200</b> 200W <b>400</b> 400W	<b>2.5</b> 2.5mm <b>3</b> 3mm <b>4</b> 4mm <b>5</b> 5mm <b>6</b> 6mm <b>8</b> 8mm <b>10</b> 10mm <b>12</b> 12mm <b>16</b> 16mm <b>20</b> 20mm <b>24</b> 24mm	<b>25</b> 25mm ? ? <b>390</b> 390mm	<b>T2</b> SCON MSCON SSEL XSEL-P/Q XSEL-RA/SA	<b>N</b> None <b>P</b> 1m <b>S</b> 3m <b>M</b> 5m <b>X</b> □□ Specified length (Standard cable) <b>R</b> □□ Robot cable	<b>B</b> Brake <b>CJT</b> Cable exit direction (Top) <b>CJR</b> Cable exit direction (Right) <b>CJL</b> Cable exit direction (Left) <b>CJO</b> Cable exit direction (Outside) <b>CJB</b> Cable exit direction (Bottom) <b>DB</b> High Rigidity Specification (Double-block guide) <b>ML</b> Motor side-mounted to left (standard) <b>MR</b> Motor side-mounted to right <b>NM</b> Non-motor End Specification <b>RP</b> Back mounting plate

\*The type of motor, ball screw lead, stroke, and selection options vary depending on the actuator type. Please refer to the pages of each type for details.

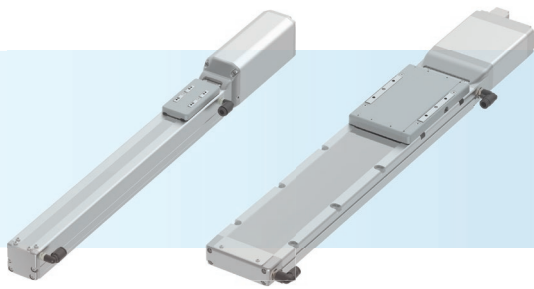

# Slider Type SA <Cleanroom Specification>

**RCS4CR** — [ ] — **WA** — [ ] — [ ] — [ ] — [ ] — [ ] — [ ]

Series      Type      Encoder Type      Motor Type      Ball Screw Lead      Stroke      Applicable Controllers      Cable Length      Options

<b>SA4C</b>	Body width 40mm Coupled motor type
<b>SA6C</b>	Body width 60mm Coupled motor type
<b>SA7C</b>	Body width 70mm Coupled motor type
<b>SA8C</b>	Body width 90mm Coupled motor type

<b>WA</b>	Battery-less Absolute
<b>60</b>	60W
<b>100</b>	100W
<b>200</b>	200W
<b>400</b>	400W

<b>50</b>	50mm
<b>?</b>	?
<b>1100</b>	1100mm

(50mm increments)

<b>2.5</b>	2.5mm
<b>3</b>	3mm
<b>4</b>	4mm
<b>5</b>	5mm
<b>6</b>	6mm
<b>8</b>	8mm
<b>10</b>	10mm
<b>12</b>	12mm
<b>16</b>	16mm
<b>20</b>	20mm
<b>24</b>	24mm

<b>T2</b>	SCON MSCON SSEL XSEL-P/Q XSEL-RA/SA
-----------	---

<b>N</b>	None
<b>P</b>	1m
<b>S</b>	3m
<b>M</b>	5m
<b>X</b> [ ]	Specified length (Standard cable)
<b>R</b> [ ]	Robot cable

<b>B</b>	Brake
<b>CJT</b>	Cable exit direction (Top)
<b>CJR</b>	Cable exit direction (Right)
<b>CJL</b>	Cable exit direction (Left)
<b>CJB</b>	Cable exit direction (Bottom)
<b>HPR</b>	High-precision Specification
<b>NM</b>	Non-motor End Specification
<b>VR</b>	Air suction joint in opposite position
<b>W</b>	Double Slider Specification

\*The type of motor, ball screw lead, stroke, and selection options vary depending on the actuator type. Please refer to the pages of each type for details.

# Wide Slider Type WSA <Cleanroom Specification>

**RCS4CR** — [ ] — **WA** — [ ] — [ ] — [ ] — [ ] — [ ] — [ ]

Series      Type      Encoder Type      Motor Type      Ball Screw Lead      Stroke      Applicable Controllers      Cable Length      Options

<b>WSA10C</b>	Body width 100mm Coupled motor type
<b>WSA12C</b>	Body width 120mm Coupled motor type
<b>WSA14C</b>	Body width 140mm Coupled motor type
<b>WSA16C</b>	Body width 160mm Coupled motor type

<b>WA</b>	Battery-less Absolute
<b>60</b>	60W
<b>100</b>	100W
<b>200</b>	200W
<b>400</b>	400W

<b>50</b>	50mm
<b>?</b>	?
<b>1100</b>	1100mm

(50mm increments)

<b>2.5</b>	2.5mm
<b>3</b>	3mm
<b>4</b>	4mm
<b>5</b>	5mm
<b>6</b>	6mm
<b>8</b>	8mm
<b>10</b>	10mm
<b>12</b>	12mm
<b>16</b>	16mm
<b>20</b>	20mm
<b>24</b>	24mm

<b>T2</b>	SCON MSCON SSEL XSEL-P/Q XSEL-RA/SA
-----------	---

<b>N</b>	None
<b>P</b>	1m
<b>S</b>	3m
<b>M</b>	5m
<b>X</b> [ ]	Specified length (Standard cable)
<b>R</b> [ ]	Robot cable

<b>B</b>	Brake
<b>CJT</b>	Cable exit direction (Top)
<b>CJR</b>	Cable exit direction (Right)
<b>CJL</b>	Cable exit direction (Left)
<b>CJB</b>	Cable exit direction (Bottom)
<b>HPR</b>	High-precision Specification
<b>NM</b>	Non-motor End Specification
<b>VR</b>	Air suction joint in opposite position

\*The type of motor, ball screw lead, stroke, and selection options vary depending on the actuator type. Please refer to the pages of each type for details.

# RCS4-SA4C

±10μm Standard
±5μm High-precision Optional
Simple Dust-proof
Battery-less Absolute
Motor Unit Type
Coupled Motor
Body Width 40mm
200v AC Servo Motor

Model Specification Items	<b>RCS4</b> — Series	<b>SA4C</b> — Type	<b>WA</b> — Encoder Type	<b>60</b> — Motor Type	Lead	Stroke	<b>T2</b> — Applicable Controllers	Cable Length	Options
			WA: Battery-less Absolute	60: Servo motor 60W	16: 16mm 10: 10mm 5: 5mm 2.5: 2.5mm	50: 50mm 500: 500mm (50mm increments)	T2: SCON MSCON SSEL XSEL-P/Q XSEL-RA/SA	N: None P: 1m S: 3m M: 5m X□□: Specified Length R□□: Robot Cable	Refer to Options table below.

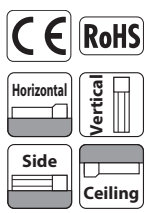

\* Depending on the model, there may be some limitations to using the vertical, side, and ceiling mount positions. Please refer to the Selection Notes on P.138 for more information.



- POINT Selection Notes**
- (1) Longer strokes may cause the maximum speed to decrease due to resonance of the ball screw. Be sure to check the maximum speed of the desired stroke in the Actuator Specifications table, which can be found below.
  - (2) Both the horizontal and vertical payloads assume operation at an acceleration of 0.3G.
  - (3) When the acceleration is increased, the payload will be reduced. Please refer to "Table of Payload by Acceleration" on P.139 for more details.
  - (4) Estimated allowable duty varies depending on operating conditions (payload, acceleration/deceleration, etc.). Please refer to P. 149 for more information.

## Actuator Specifications

### Lead and Payload

Model Number	Motor wattage (W)	Lead (mm)	Max. payload		Rated thrust (N)	Stroke (mm)
			Horizontal (kg)	Vertical (kg)		
RCS4-SA4C-WA-60-16-①-T2-②-③	60	16	10	3	53	50~500 (50mm increments)
RCS4-SA4C-WA-60-10-①-T2-②-③		10	14	5	85	
RCS4-SA4C-WA-60-5-①-T2-②-③		5	17	8	170	
RCS4-SA4C-WA-60-2.5-①-T2-②-③		2.5	20	12	340	

Legend: ① Stroke ② Cable Length ③ Option

### Stroke and Max Speed (Unit: mm/s)

Lead	Stroke	50~450 (50mm increments)	
		500 (mm)	500 (mm)
16	960	875	
10	600	555	
5	300	275	
2.5	150	135	

### ① Stroke

① Stroke (mm)	RCS4-SA4C	① Stroke (mm)	RCS4-SA4C
50	○	300	○
100	○	350	○
150	○	400	○
200	○	450	○
250	○	500	○

### ② Cable Length

Type	Cable Code
Standard	P(1m)
	S(3m)
	M(5m)
Specified length (Standard cable)	X06(6m) ~ X10(10m)
	X11(11m) ~ X15(15m)
	X16(16m) ~ X20(20m)
Robot cable	R01(1m) ~ R03(3m)
	R04(4m) ~ R05(5m)
	R06(6m) ~ R10(10m)
	R11(11m) ~ R15(15m)
	R16(16m) ~ R20(20m)

### ③ Options

Name	Option Code	Reference Page
Brake	<b>B</b>	See P.131
Cable exit direction (Top)	<b>CJT</b>	See P.131
Cable exit direction (Right)	<b>CJR</b>	See P.131
Cable exit direction (Left)	<b>CJL</b>	See P.131
Cable exit direction (Bottom)	<b>CJB</b>	See P.131
High-Precision specification (*1)	<b>HPR</b>	See P.134
Non-motor end specification	<b>NM</b>	See P.136
Slider roller specification	<b>SR</b>	See P.137
Double slider specification (*2)	<b>W</b>	See P.137

(\*1) Double slider specification cannot be selected.  
(\*2) Some leads cannot be selected. (Please see P. 150)

### Actuator Specifications

Item	Description
Drive system	Ball screw φ8mm, rolled C10
Positioning repeatability (*1)	±0.01mm [±0.005mm]
Lost motion	0.1mm or less
Base	Material: Aluminum with white alumite treatment
Allowable static moment	Ma direction: 13.0N·m, Mb direction: 18.6N·m, Mc direction: 25.3N·m
Allowable dynamic moment (*2)	Ma direction: 5.0N·m, Mb direction: 7.1N·m, Mc direction: 9.7N·m
Ambient operating temp. & humidity	0~40°C, 85% RH or less (Non-condensing)

\* Reference for overhang load length: Ma direction: 150mm or less, Mb, Mc direction: 150mm or less  
(\*1) Values in [ ] are for high precision specification.  
(\*2) Assumes a standard rated life of 5,000km. The service life will vary depending on operation and installation conditions. Please contact IAI America for details of the running life. See page 146 for moment load directions.

If the moment loads in Ma/Mb/Mc are within the allowable ranges, there is no overhang length limit.

CAD drawings can be downloaded from our website.  
www.intelligentactuator.com



\*1 When the slider is returning to its home position, please be careful of interference from surrounding objects, as it will travel until it reaches the M.E.  
M.E: Mechanical end S.E: Stroke end

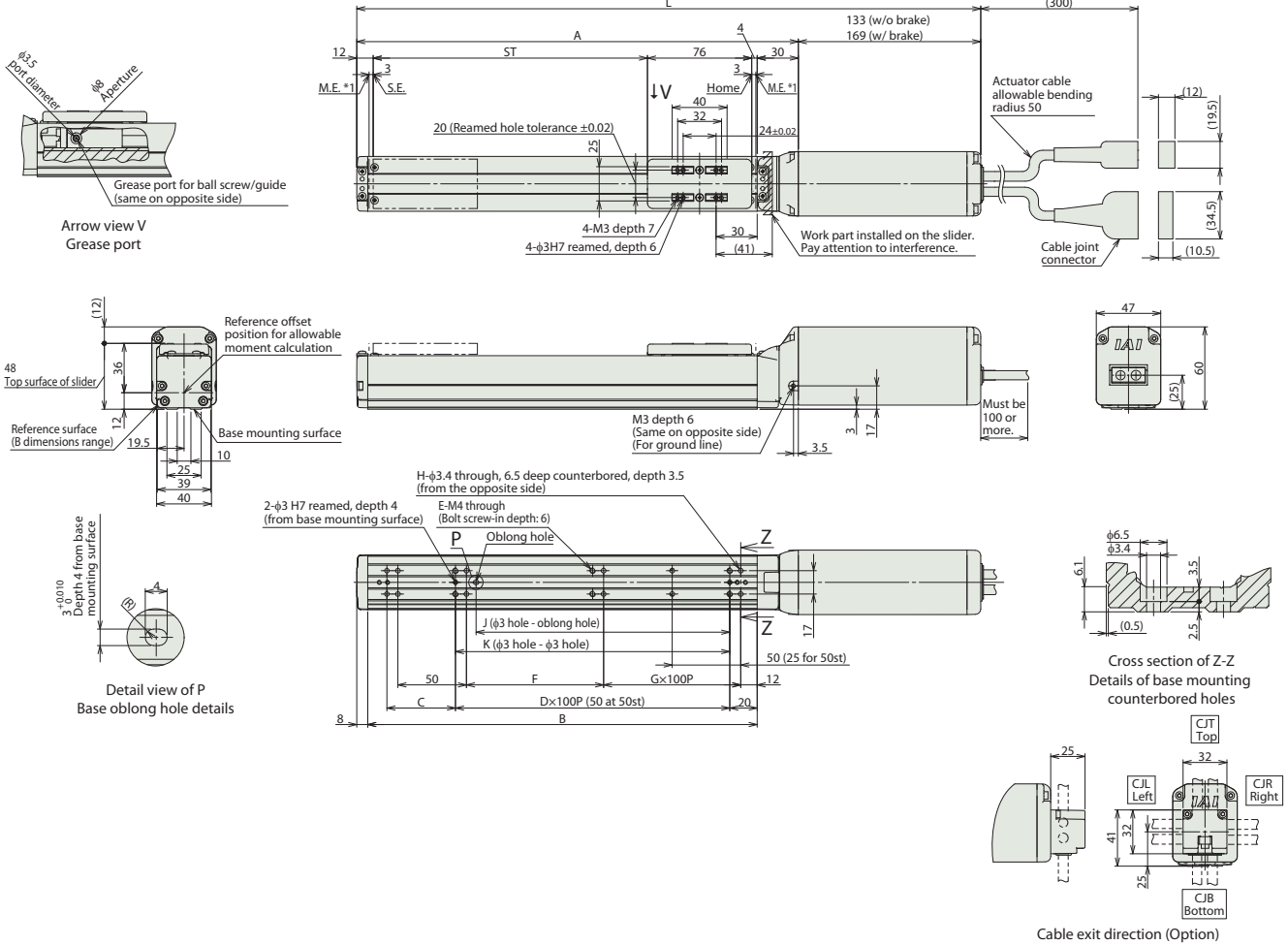

■ Dimensions and Mass by Stroke

L	Stroke	50	100	150	200	250	300	350	400	450	500
	W/o brake	305	355	405	455	505	555	605	655	705	755
	W/ brake	341	391	441	491	541	591	641	691	741	791
	A	172	222	272	322	372	422	472	522	572	622
	B	134	184	234	284	334	384	434	484	534	584
	C	50	50	100	50	100	50	100	50	100	50
	D	-	1	1	2	2	3	3	4	4	5
	E	6	6	6	8	8	10	10	12	12	14
	F	50	100	50	100	50	100	50	100	50	100
	G	0	0	1	1	2	2	3	3	4	4
	H	8	8	10	10	12	12	14	14	16	16
	J	35	85	85	185	185	285	285	385	385	485
	K	50	100	100	200	200	300	300	400	400	500
Mass (kg)	W/o brake	1.2	1.3	1.4	1.5	1.5	1.6	1.7	1.8	1.9	2.0
	W/ brake	1.4	1.5	1.6	1.7	1.7	1.8	1.9	2.0	2.1	2.2

Applicable Controllers

The RCS4 series actuators can be operated by the controllers indicated below. Please select the type depending on your intended use.

Name	External view	Max. number of connectable axes	Input power	Control method				Maximum number of positioning points	Reference page	
				Positioner	Pulse train	Program	Network * Option			
SCON-CB/CGB		1	Single phase 100V/200VAC	●	●	-	DeviceNet CC-Link CC-Link IE CompoNet MECHATROLINK EtherCAT EtherNet/IP EtherCAT	512 (768 for network spec.)	Please contact IAI for more information.	
SCON-LC/LCG		1		-	-	●		512 (768 for network spec.)		
SCON-CAL/CGAL		1		●	-	-		512 (768 for network spec.)		
MSCON-C		6		This model is network-compatible only.				256		
SSEL-CS		2		●	-	●		20000		
XSEL-P/Q/RA/SA		8	Single phase 200VAC Three-phase 200VAC	-	-	●	55000 (Depending on the type)			

Note: The type of compatible networks will vary depending on the controller. Please refer to the reference page for more information.

Foreword  
Slider Type  
Wide Slider Type  
Rod Type  
Radial Cylinder  
Wide Radial Cylinder  
Table Type  
Cleanroom Slider  
Cleanroom Wide Slider  
Options  
Reference Data  
Controller

# RCS4-SA6C

±10μm Standard
±5μm High precision Optional
Simple Dust-proof
Battery-less Absolute
Motor Unit Type
Coupled Motor
Body Width 60mm
200v AC Servo Motor

Model Specification Items	<b>RCS4</b> — <b>SA6C</b> — <b>WA</b> — <b>100</b> — [ ] — [ ] — [ ] — <b>T2</b> — [ ] — [ ]
	Series — Type — Encoder Type — Motor Type — Lead — Stroke — Applicable Controllers — Cable Length — Options
	WA: Battery-less Absolute      100: Servo motor 100W      30:30mm 20:20mm 12:12mm 6: 6mm 3: 3mm 50:50mm 800:800mm (50mm increments)
	T2:SCON MSCON SSEL XSEL-P/Q XSEL-RA/SA N : None P : 1m S : 3m M : 5m X□ : Specified Length R□ : Robot Cable
	Refer to Options table below.

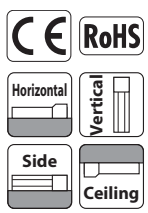

\* Depending on the model, there may be some limitations to using the vertical, side, and ceiling mount positions. Please refer to the Selection Notes on P.138 for more information.



- POINT Selection Notes**
- (1) Longer strokes may cause the maximum speed to decrease due to resonance of the ball screw. Be sure to check the maximum speed of the desired stroke in the Actuator Specifications table, which can be found below.
  - (2) Both the horizontal and vertical payloads assume operation at an acceleration of 0.3G.
  - (3) When the acceleration is increased, the payload will be reduced. Please refer to "Table of Payload by Acceleration" on P.139 for more details.
  - (4) Estimated allowable duty varies depending on operating conditions (payload, acceleration/deceleration, etc.). Please refer to P. 149 for more information.

## Actuator Specifications

### Lead and Payload

Model Number	Motor wattage (W)	Lead (mm)		Max. payload		Rated thrust (N)	Stroke (mm)
		Horizontal (kg)	Vertical (kg)	Horizontal (kg)	Vertical (kg)		
RCS4-SA6C-WA-100-30-①-T2-②-③	100	30	11	3.5	57	50~800 (50mm increments)	
RCS4-SA6C-WA-100-20-①-T2-②-③		20	18	6	85		
RCS4-SA6C-WA-100-12-①-T2-②-③		12	30	11	142		
RCS4-SA6C-WA-100-6-①-T2-②-③		6	45	15	283		
RCS4-SA6C-WA-100-3-①-T2-②-③		3	45	15	566		

### Stroke and Max Speed

(Unit: mm/s)

Stroke / Lead	Stroke (mm)						
	50~500 (50mm increments)	550	600	650	700	750	800
30	1600	1450	1260	1100	970	860	
20	1200	1130	970	840	735	650	575
12	720	620	535	460	405	355	315
6	360	305	265	230	200	175	155
3	180	150	130	115	100	85	75

Legend: ① Stroke ② Cable Length ③ Option

### ① Stroke

① Stroke (mm)	RCS4-SA6C	① Stroke (mm)	RCS4-SA6C
50	○	450	○
100	○	500	○
150	○	550	○
200	○	600	○
250	○	650	○
300	○	700	○
350	○	750	○
400	○	800	○

### ② Cable Length

Type	Cable Code
Standard	P(1m)
	S(3m)
	M(5m)
Specified length (Standard cable)	X06(6m) ~ X10(10m)
	X11(11m) ~ X15(15m)
	X16(16m) ~ X20(20m)
Robot cable	R01(1m) ~ R03(3m)
	R04(4m) ~ R05(5m)
	R06(6m) ~ R10(10m)
	R11(11m) ~ R15(15m)
	R16(16m) ~ R20(20m)

### ③ Options

Name	Option Code	Reference Page
Brake	B	See P.131
Cable exit direction (Top)	CJT	See P.131
Cable exit direction (Right)	CJR	See P.131
Cable exit direction (Left)	CJL	See P.131
Cable exit direction (Bottom)	CJB	See P.131
High-Precision specification (*1)	HPR	See P.134
Non-motor end specification	NM	See P.136
Slider roller specification	SR	See P.137
Double slider specification (*2)	W	See P.137

(\*1) When the lead is 30, it cannot be selected.  
 Double slider specification cannot be selected.  
 (\*2) Some leads cannot be selected. (Please see P. 150)

### Actuator Specifications

Item	Description
Drive system	Ball screw φ10mm, rolled C10
Positioning repeatability (*1)	±0.01mm [±0.005mm]
Lost motion	0.1mm or less
Base	Material: Aluminum with white alumite treatment
Allowable static moment	Ma direction: 48.5N·m, Mb direction: 69.3N·m, Mc direction: 103N·m
Allowable dynamic moment (*2)	Ma direction: 11.6N·m, Mb direction: 16.6N·m, Mc direction: 24.6N·m
Ambient operating temp. & humidity	0~40°C, 85% RH or less (Non-condensing)

\* Reference for overhang load length: Ma direction: 220mm or less, Mb, Mc direction: 220mm or less  
 (\*1) Values in [ ] are for high precision (for lead 3/6/12/20) specification.  
 (\*2) Assumes a standard rated life of 5,000km. The running life will vary depending on operation and installation conditions. Please contact IAI America for details of the running life.  
 See page 146 for moment load directions.  
 If the moment loads in Ma/Mb/Mc are within the allowable ranges, there is no overhang length limit.

CAD drawings can be downloaded from our website.  
www.intelligentactuator.com



\*1 When the slider is returning to its home position, please be careful of interference from surrounding objects, as it will travel until it reaches the M.E.  
M.E: Mechanical end S.E: Stroke end

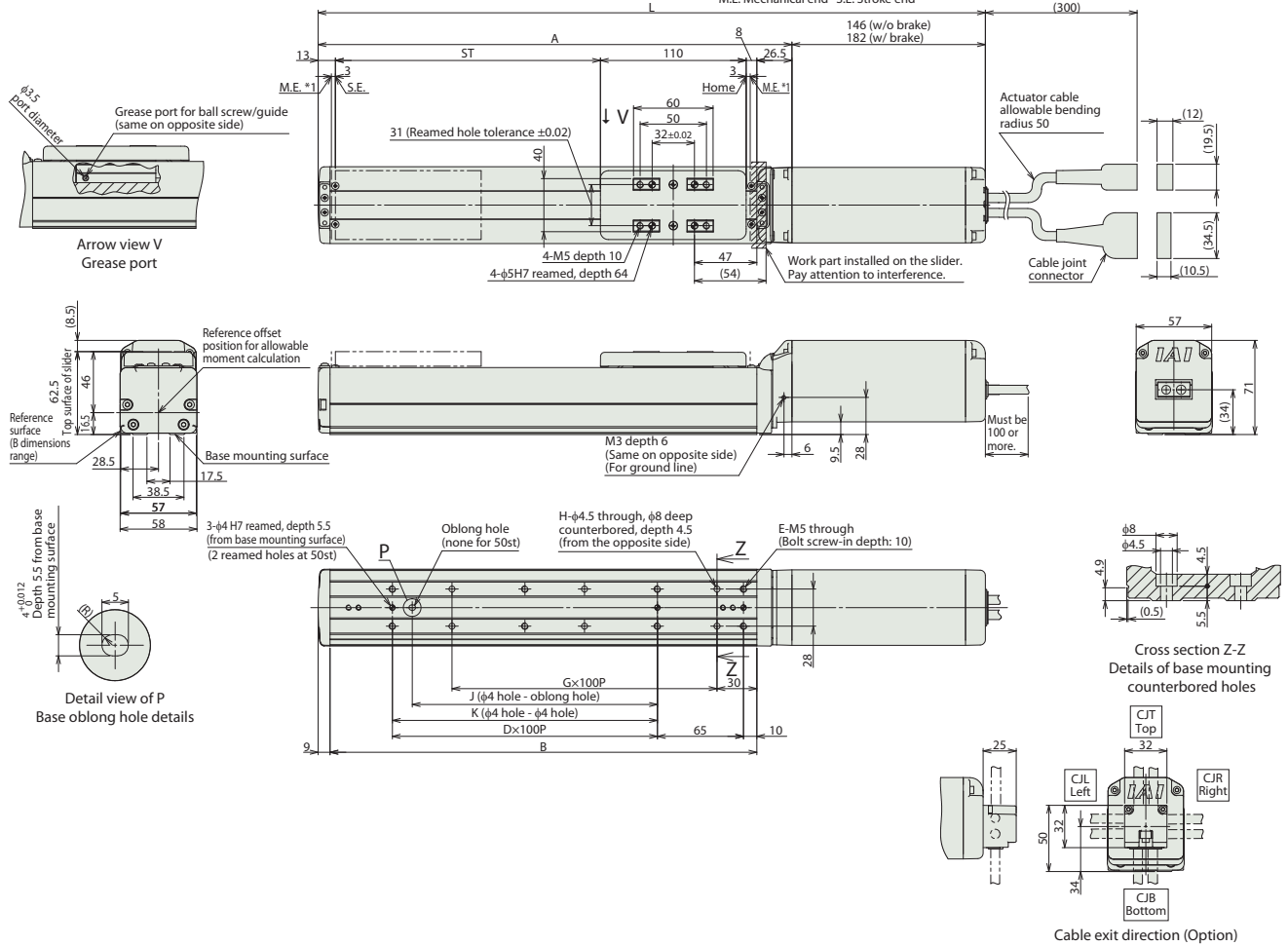

■ Dimensions and Mass by Stroke

L	Stroke	50	100	150	200	250	300	350	400	450	500	550	600	650	700	750	800
	W/o brake	353.5	403.5	453.5	503.5	553.5	603.5	653.5	703.5	753.5	803.5	853.5	903.5	953.5	1003.5	1053.5	1103.5
W/ brake	389.5	439.5	489.5	539.5	589.5	639.5	689.5	739.5	789.5	839.5	889.5	939.5	989.5	1039.5	1089.5	1139.5	1139.5
A	207.5	257.5	307.5	357.5	407.5	457.5	507.5	557.5	607.5	657.5	707.5	757.5	807.5	857.5	907.5	957.5	957.5
B	172	222	272	322	372	422	472	522	572	622	672	722	772	822	872	922	922
D	0	1	1	2	2	3	3	4	4	5	5	6	6	7	7	8	8
E	4	6	6	8	8	10	10	12	12	14	14	16	16	18	18	20	20
G	1	1	2	2	3	3	4	4	5	5	6	6	7	7	8	8	8
H	4	4	6	6	8	8	10	10	12	12	14	14	16	16	18	18	18
J	0	85	85	185	185	285	285	385	385	485	485	585	585	685	685	785	785
K	0	100	100	200	200	300	300	400	400	500	500	600	600	700	700	800	800
Mass (kg)	W/o brake	2.0	2.2	2.4	2.6	2.7	2.9	3.1	3.3	3.4	3.6	3.8	4.0	4.2	4.3	4.5	4.7
	W/ brake	2.3	2.5	2.7	2.9	3.0	3.2	3.4	3.6	3.7	3.9	4.1	4.3	4.5	4.6	4.8	5.0

Applicable Controllers

The RCS4 series actuators can be operated by the controllers indicated below. Please select the type depending on your intended use.

Name	External view	Max. number of connectable axes	Input power	Control method				Maximum number of positioning points	Reference page	
				Positioner	Pulse train	Program	Network * Option			
SCON-CB/CGB		1	Single phase 100V/200VAC	●	●	-	DeviceNet CC-Link CompoNet MECHATROLINK EtherCAT EtherNet/IP	512 (768 for network spec.)	Please contact IAI for more information.	
SCON-LC/LCG		1		-	-	●		512 (768 for network spec.)		
SCON-CAL/CGAL		1		●	-	-		512 (768 for network spec.)		
MSCON-C		6		This model is network-compatible only.				256		
SSEL-CS		2		●	-	●		20000		
XSEL-P/Q/RA/SA		8	Single phase 200VAC Three-phase 200VAC	-	-	●	55000 (Depending on the type)			

Note: The type of compatible networks will vary depending on the controller. Please refer to the reference page for more information.

Foreword  
Slider Type  
Wide Slider Type  
Rod Type  
Radial Cylinder  
Wide Radial Cylinder  
Table Type  
Cleanroom Slider  
Cleanroom Wide Slider  
Options  
Reference Data  
Controller

# RCS4-SA7C



Model Specification Items	<b>RCS4</b> — <b>SA7C</b> — <b>WA</b> — <b>200</b> — [ ] — [ ] — [ ] — <b>T2</b> — [ ] — [ ]
	Series — Type — Encoder Type — Motor Type — Lead — Stroke — Applicable Controllers — Cable Length — Options
	WA: Battery-less Absolute      200: Servo motor 200W      36:36mm 24:24mm 16:16mm 8: 8mm 4: 4mm      50:50mm 800:800mm (50mm increments)
	T2:SCON MSCON SSEL XSEL-P/Q XSEL-RA/SA      N : None P : 1m S : 3m M : 5m      Refer to Options table below.
	X□ : Specified Length R□ : Robot Cable

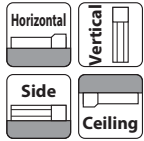

\* Depending on the model, there may be some limitations to using the vertical, side, and ceiling mount positions. Please refer to the Selection Notes on P.138 for more information.



- POINT Selection Notes**
- (1) Longer strokes may cause the maximum speed to decrease due to resonance of the ball screw. Be sure to check the maximum speed of the desired stroke in the Actuator Specifications table, which can be found below.
  - (2) Both the horizontal and vertical payloads assume operation at an acceleration of 0.3G.
  - (3) When the acceleration is increased, the payload will be reduced. Please refer to "Table of Payload by Acceleration" on P.139 for more details.
  - (4) Estimated allowable duty varies depending on operating conditions (payload, acceleration/deceleration, etc.). Please refer to P. 149 for more information.

## Actuator Specifications

### Lead and Payload

Model Number	Motor wattage (W)	Lead (mm)	Max. payload (kg)	Rated thrust (N)	Stroke (mm)	
RCS4-SA7C-WA-200-36-①-T2-②-③	200	36	7	4	50~800 (50mm increments)	
RCS4-SA7C-WA-200-24-①-T2-②-③		24	30	7		142
RCS4-SA7C-WA-200-16-①-T2-②-③		16	40	12		214
RCS4-SA7C-WA-200-8-①-T2-②-③		8	45	20		427
RCS4-SA7C-WA-200-4-①-T2-②-③		4	50	25		855

### Stroke and Max Speed

(Unit: mm/s)

Stroke / Lead	Stroke (mm)						
	50~500 (50mm increments)	550 (mm)	600 (mm)	650 (mm)	700 (mm)	750 (mm)	800 (mm)
36	1800			1620	1420	1260	1120
24	1500	1440	1240	1095	965	850	760
16	1000	965	830	720	635	560	500
8	500	475	410	355	315	275	245
4	240	235	205	175	155	135	120

Legend: ① Stroke ② Cable Length ③ Option

### ① Stroke

① Stroke (mm)	RCS4-SA7C	① Stroke (mm)	RCS4-SA7C
50	○	450	○
100	○	500	○
150	○	550	○
200	○	600	○
250	○	650	○
300	○	700	○
350	○	750	○
400	○	800	○

### ② Cable Length

Type	Cable Code
Standard	P(1m)
	S(3m)
	M(5m)
Specified length (Standard cable)	X06(6m) ~ X10(10m)
	X11(11m) ~ X15(15m)
	X16(16m) ~ X20(20m)
Robot cable	R01(1m) ~ R03(3m)
	R04(4m) ~ R05(5m)
	R06(6m) ~ R10(10m)
	R11(11m) ~ R15(15m)
	R16(16m) ~ R20(20m)

### ③ Options

Name	Option Code	Reference Page
Brake	B	See P.131
Cable exit direction (Top)	CJT	See P.131
Cable exit direction (Right)	CJR	See P.131
Cable exit direction (Left)	CJL	See P.131
Cable exit direction (Bottom)	CJB	See P.131
High-Precision specification (*1)	HPR	See P.134
Non-motor end specification	NM	See P.136
Slider roller specification	SR	See P.137
Double slider specification (*2)	W	See P.137

(\*1) When the lead is 24/36, it cannot be selected.

Double slider specification cannot be selected.

(\*2) Some leads cannot be selected. (Please see P. 150)

### Actuator Specifications

Item	Description
Drive system	Ball screw φ12mm, rolled C10
Positioning repeatability (*1)	±0.01mm [±0.005mm]
Lost motion	0.1mm or less
Base	Material: Aluminum with white alumite treatment
Allowable static moment	Ma direction 115N·m, Mb direction 115N·m, Mc direction 229N·m
Allowable dynamic moment (*2)	Ma direction 44.7N·m, Mb direction 44.7N·m, Mc direction 89.1N·m
Ambient operating temp. & humidity	0~40°C, 85% RH or less (Non-condensing)

\* Reference for overhang load length: Ma direction: 300mm or less, Mb, Mc direction: 300mm or less

(\*1) Values in [ ] are for high precision (for lead 4/8/16) specification.

(\*2) Assumes a standard rated life of 5,000km. The running life will vary depending on operation and installation conditions. Please contact IAI America for details of the running life.

See page 146 for moment load directions.

If the moment loads in Ma/Mb/Mc are within the allowable ranges, there is no overhang length limit.



CAD drawings can be downloaded from our website.  
www.intelligentactuator.com



\*1 When the slider is returning to its home position, please be careful of interference from surrounding objects, as it will travel until it reaches the M.E.  
M.E: Mechanical end S.E: Stroke end

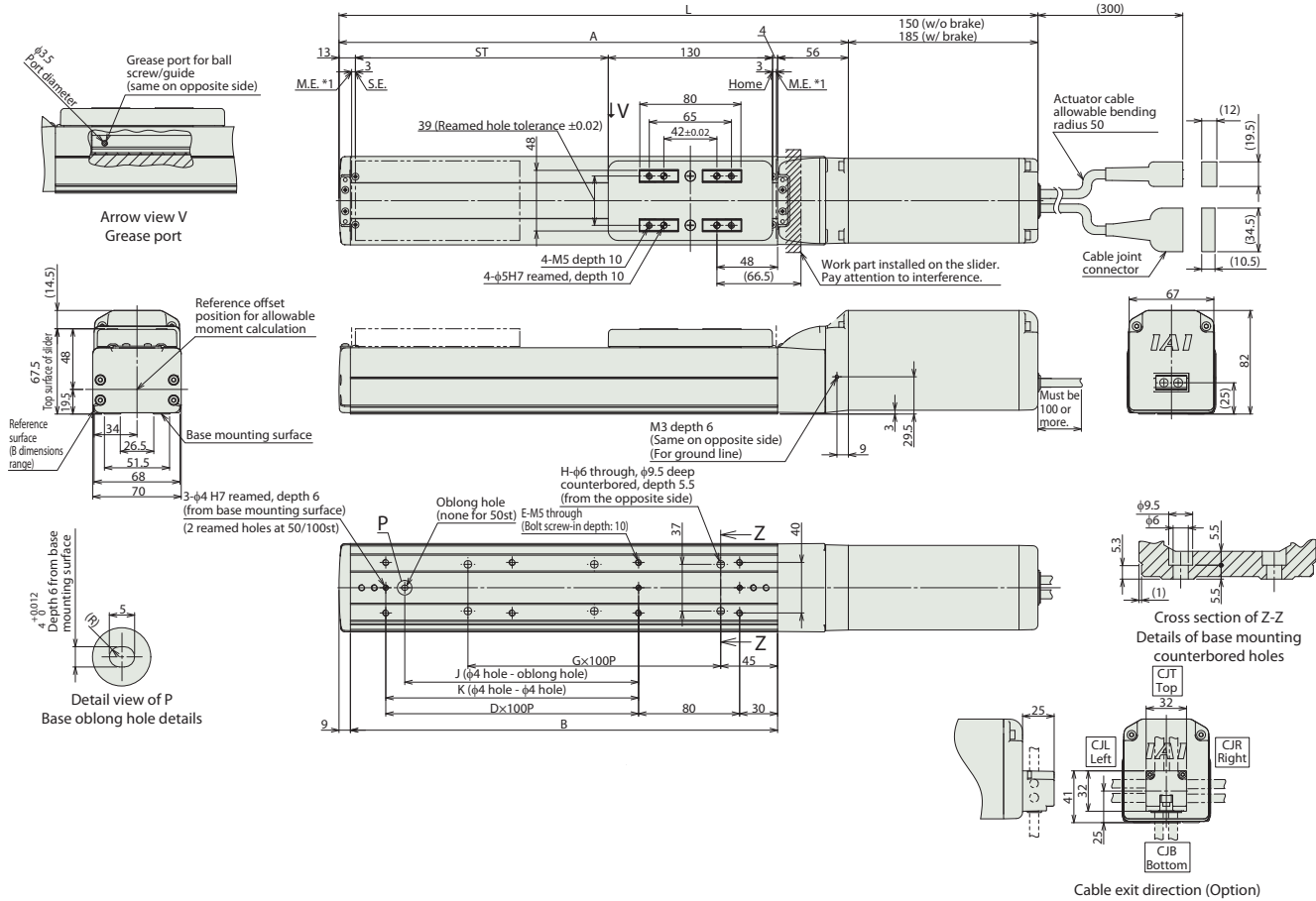

■ Dimensions and Mass by Stroke

L	Stroke	50	100	150	200	250	300	350	400	450	500	550	600	650	700	750	800
	W/o brake	403	453	503	553	603	653	703	753	803	853	903	953	1003	1053	1103	1153
W/ brake	438	488	538	588	638	688	738	788	838	888	938	988	1038	1088	1138	1188	
A	253	303	353	403	453	503	553	603	653	703	753	803	853	903	953	1003	
B	188	238	288	338	388	438	488	538	588	638	688	738	788	838	888	938	
D	0	1	1	2	2	3	3	4	4	5	5	6	6	7	7	8	
E	4	6	6	8	8	10	10	12	12	14	14	16	16	18	18	20	
G	1	1	2	2	3	3	4	4	5	5	6	6	7	7	8	8	
H	4	4	6	6	8	8	10	10	12	12	14	14	16	16	18	18	
J	0	85	85	185	185	285	285	385	385	485	485	585	585	685	685	785	
K	0	0	100	200	200	300	300	400	400	500	500	600	600	700	700	800	
Mass (kg)	W/o brake	3.5	3.8	4.0	4.3	4.5	4.7	5.0	5.2	5.4	5.7	5.9	6.1	6.4	6.6	6.8	7.1
	W/ brake	4.0	4.3	4.5	4.8	5.0	5.2	5.5	5.7	5.9	6.2	6.4	6.6	6.9	7.1	7.3	7.6

Applicable Controllers

The RCS4 series actuators can be operated by the controllers indicated below. Please select the type depending on your intended use.

Name	External view	Max. number of connectable axes	Input power	Control method				Maximum number of positioning points	Reference page	
				Positioner	Pulse train	Program	Network * Option			
SCON-CB/CGB		1	Single phase 100V/200VAC	●	●	—	DeviceNet CC-Link CC-Link IE CompoNet MECHATROLINK EtherCAT EtherNet/IP	512 (768 for network spec.)	Please contact IAI for more information.	
SCON-LC/LCG		1		—	—	●		512 (768 for network spec.)		
SCON-CAL/CGAL		1		●	—	—		512 (768 for network spec.)		
MSCON-C		6		This model is network-compatible only.				256		
SSEL-CS		2		●	—	●		20000		
XSEL-P/Q/RA/SA		8	Single phase 200VAC Three-phase 200VAC	—	—	●	55000 (Depending on the type)			

Note:  
The type of compatible networks will vary depending on the controller. Please refer to the reference page for more information.

# RCS4-SA8C



Model Specification Items	<b>RCS4</b> — <b>SA8C</b> — <b>WA</b> — <b>400</b> — [ ] — [ ] — [ ] — <b>T2</b> — [ ] — [ ]
	Series — Type — Encoder Type — Motor Type — Lead — Stroke — Applicable Controllers — Cable Length — Options
	WA: Battery-less Absolute      400: Servo motor 400W      48:48mm 30:30mm 20:20mm 10:10mm 5: 5mm      50:50mm 1100:1100mm (50mm increments)      T2:SCON SSEL XSEL-P/Q XSEL-RA/SA      N : None P : 1m S : 3m M : 5m      Refer to Options table below.      X [ ] : Specified Length R [ ] : Robot Cable



\* Depending on the model, there may be some limitations to using the vertical, side, and ceiling mount positions. Please refer to the Selection Notes on P.138 for more information.



**POINT Selection Notes**

- (1) Longer strokes may cause the maximum speed to decrease due to resonance of the ball screw. Be sure to check the maximum speed of the desired stroke in the Actuator Specifications table, which can be found below.
- (2) Both the horizontal and vertical payloads assume operation at an acceleration of 0.3G.
- (3) When the acceleration is increased, the payload will be reduced. Please refer to "Table of Payload by Acceleration" on P.139 for more details.
- (4) Estimated allowable duty varies depending on operating conditions (payload, acceleration/deceleration, etc.). Please refer to P. 149 for more information.

## Actuator Specifications

### Lead and Payload

Model Number	Motor wattage (W)	Lead (mm)	Max. payload (kg)	Rated thrust (N)	Stroke (mm)
RCS4-SA8C-WA-400-48-①-T2-②-③	400	48	8	141	50~1100 (50mm increments)
RCS4-SA8C-WA-400-30-①-T2-②-③		30	30	226	
RCS4-SA8C-WA-400-20-①-T2-②-③		20	60	339	
RCS4-SA8C-WA-400-10-①-T2-②-③		10	80	678	
RCS4-SA8C-WA-400-5-①-T2-②-③		5	90	1357	

Legend: ① Stroke ② Cable Length ③ Option

### Stroke and Max Speed

(Unit: mm/s)

Stroke	Lead										
	50~600 (50mm increments)	650 (mm)	700 (mm)	750 (mm)	800 (mm)	850 (mm)	900 (mm)	950 (mm)	1000 (mm)	1050 (mm)	1100 (mm)
48	2200		2180	1950	1760	1590	1450	1320	1210	1110	
30	1800	1640	1440	1280	1155	1040	940	855	780	715	660
20	1200	1090	960	860	770	695	630	570	520	480	440
10	600	540	480	430	385	345	310	285	260	235	220
5	300	270	240	215	190	175	155	140	130	120	110

### ① Stroke

① Stroke (mm)	RCS4-SA8C	① Stroke (mm)	RCS4-SA8C
50	○	600	○
100	○	650	○
150	○	700	○
200	○	750	○
250	○	800	○
300	○	850	○
350	○	900	○
400	○	950	○
450	○	1000	○
500	○	1050	○
550	○	1100	○

### ③ Options

Name	Option Code	Reference Page
Brake	<b>B</b>	See P.131
Cable exit direction (Top)	<b>CJT</b>	See P.131
Cable exit direction (Right)	<b>CJR</b>	See P.131
Cable exit direction (Left)	<b>CJL</b>	See P.131
Cable exit direction (Bottom)	<b>CJB</b>	See P.131
High-Precision specification (*1)	<b>HPR</b>	See P.134
Non-motor end specification	<b>NM</b>	See P.136
Slider roller specification	<b>SR</b>	See P.137
Double slider specification (*2)	<b>W</b>	See P.137

(\*1) When the lead is 30/48, it cannot be selected. Double slider specification cannot be selected.  
(\*2) Some leads cannot be selected. (Please see P. 130)

### ② Cable Length

Type	Cable Code
Standard	<b>P</b> (1m)
	<b>S</b> (3m)
	<b>M</b> (5m)
Specified length (Standard cable)	<b>X06</b> (6m) ~ <b>X10</b> (10m)
	<b>X11</b> (11m) ~ <b>X15</b> (15m)
	<b>X16</b> (16m) ~ <b>X20</b> (20m)
Robot cable	<b>R01</b> (1m) ~ <b>R03</b> (3m)
	<b>R04</b> (4m) ~ <b>R05</b> (5m)
	<b>R06</b> (6m) ~ <b>R10</b> (10m)
	<b>R11</b> (11m) ~ <b>R15</b> (15m)
	<b>R16</b> (16m) ~ <b>R20</b> (20m)

### Actuator Specifications

Item	Description
Drive system	Ball screw φ16mm, rolled C10
Positioning repeatability (*1)	±0.01mm [±0.005mm]
Lost motion	0.1mm or less
Base	Material: Aluminum with white alumite treatment
Allowable static moment	Ma direction 219N·m, Mb direction 219N·m, Mc direction 414N·m
Allowable dynamic moment (*2)	Ma direction 77.0N·m, Mb direction 77.0N·m, Mc direction 146N·m
Ambient operating temp. & humidity	0~40°C, 85% RH or less (Non-condensing)

\* Reference for overhang load length: Ma direction: 400mm or less, Mb, Mc direction: 400mm or less

(\*1) Values in [ ] are for high precision (for lead 5/10/20) specification.

(\*2) Assumes a standard rated life of 5,000km. The running life will vary depending on operation and installation conditions. Please contact IAI America for details of the running life.

See page 146 for moment load directions.

If the moment loads in Ma/Mb/Mc are within the allowable ranges, there is no overhang length limit.



\*1 When the slider is returning to its home position, please be careful of interference from surrounding objects, as it will travel until it reaches the M.E.

M.E: Mechanical end S.E: Stroke end

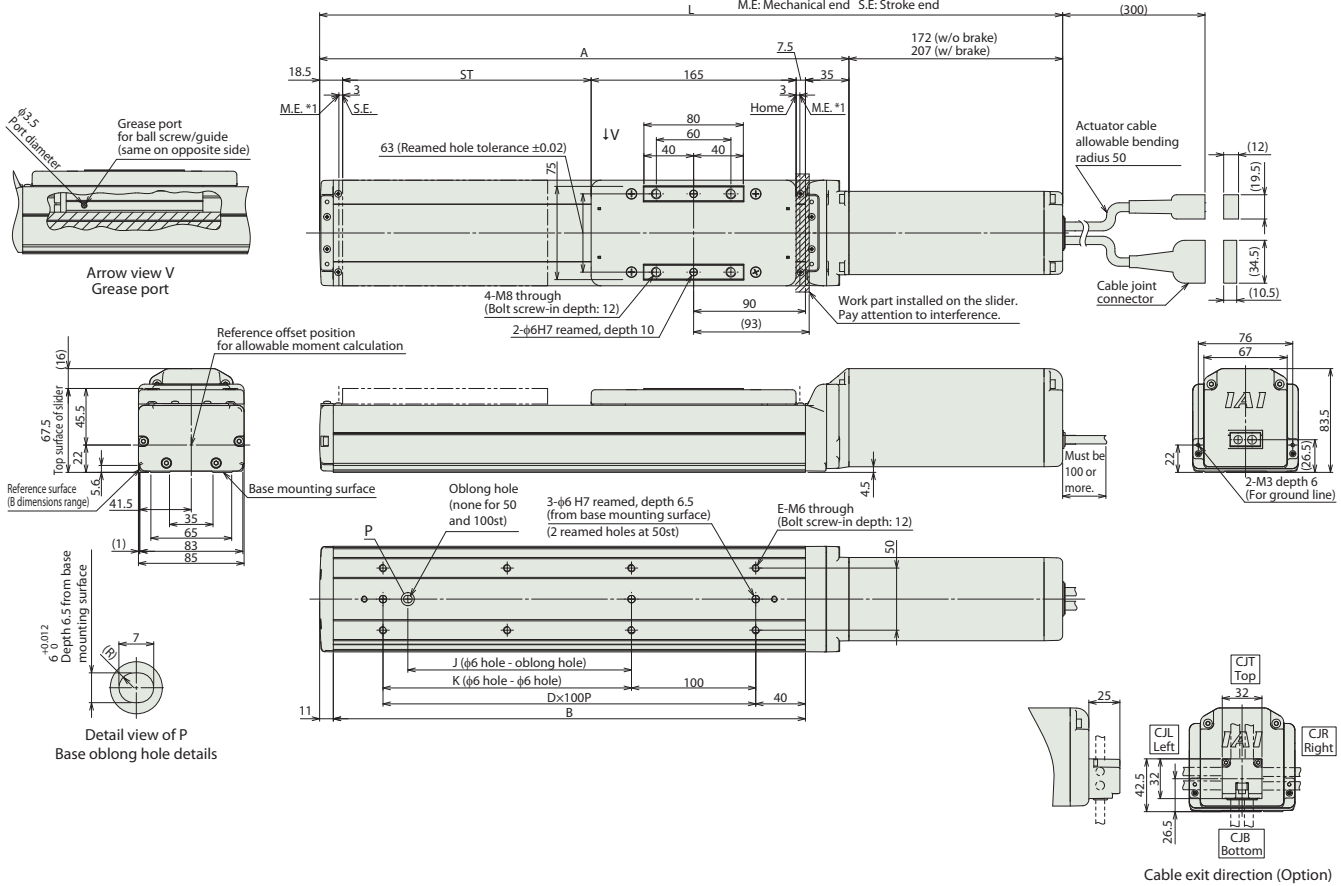

■ Dimensions and Mass by Stroke

L	Stroke	50	100	150	200	250	300	350	400	450	500	550	600	650	700	750	800	850	900	950	1000	1050	1100
	W/o brake	448	498	548	598	648	698	748	798	848	898	948	998	1048	1098	1148	1198	1248	1298	1348	1398	1448	1498
W/ brake	483	533	583	633	683	733	783	833	883	933	983	1033	1083	1133	1183	1233	1283	1333	1383	1433	1483	1533	
A	276	326	376	426	476	526	576	626	676	726	776	826	876	926	976	1026	1076	1126	1176	1226	1276	1326	
B	230	280	330	380	430	480	530	580	630	680	730	780	830	880	930	980	1030	1080	1130	1180	1230	1280	
D	1	2	2	3	3	4	4	5	5	6	6	7	7	8	8	9	9	10	10	11	11	12	
E	4	6	6	8	8	10	10	12	12	14	14	16	16	18	18	20	20	22	22	24	24	26	
J	0	0	80	180	180	280	280	380	380	480	480	580	580	680	680	780	780	880	880	980	980	1080	
K	0	100	100	200	200	300	300	400	400	500	500	600	600	700	700	800	800	900	900	1000	1000	1100	
Mass (kg)	W/o brake	4.7	5.0	5.3	5.6	5.9	6.2	6.5	6.8	7.1	7.4	7.6	7.9	8.2	8.5	8.8	9.1	9.4	9.7	10.0	10.3	10.6	10.8
	W/ brake	5.2	5.5	5.8	6.1	6.4	6.7	7.0	7.3	7.6	7.9	8.1	8.4	8.7	9.0	9.3	9.6	9.9	10.2	10.5	10.8	11.1	11.3

Applicable Controllers

The RCS4 series actuators can be operated by the controllers indicated below. Please select the type depending on your intended use.

Name	External view	Max. number of connectable axes	Input power	Control method				Network * Option	Maximum number of positioning points	Reference page
				Positioner	Pulse train	Program				
SCON-CB/CGB		1	Single phase 200VAC	●	●	-	<b>DeviceNet</b> <b>CC-Link</b> <b>PROFINET</b> <b>CompoNet</b> <b>MECHATROLINK</b> <b>EtherCAT</b> <b>EtherNet/IP</b> Note: The type of compatible networks will vary depending on the controller. Please refer to the reference page for more information.	512 (768 for network spec.)	Please contact IAI for more information.	
SCON-LC/LCG		1		-	-	●		512 (768 for network spec.)		
SSEL-CS		2	Single phase 100V/200VAC	●	-	●		20000		
XSEL-P/Q/RA/SA		8	Single phase 200VAC Three-phase 200VAC	-	-	●		55000 (Depending on the type)		

# RCS4-SA4R



Model Specification Items	<b>RCS4</b> — <b>SA4R</b> — <b>WA</b> — <b>60</b> — <input type="checkbox"/> — <input type="checkbox"/> — <input type="checkbox"/> — <input type="checkbox"/> — <input type="checkbox"/> — <input type="checkbox"/> — <input type="checkbox"/>	<b>T2</b> — <input type="checkbox"/> — <input type="checkbox"/>	* Body width does not include the width of the side-mounted motor.					
Series	Type	Encoder Type	Motor Type	Lead	Stroke	Applicable Controllers	Cable Length	Options
		WA: Battery-less Absolute	60: Servo motor 60W	16:16mm 10:10mm 5: 5mm 2.5:2.5mm	50:50mm 500:500mm (50mm increments)	T2:SCON MCON SSEL XSEL-P/Q XSEL-RA/SA	N : None P : 1m S : 3m M : 5m X□□ : Specified Length R□□ : Robot Cable	Refer to Options table below.

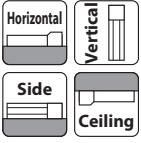

\* Depending on the model, there may be some limitations to using the vertical, side, and ceiling mount positions. Please refer to the Selection Notes on P.138 for more information.

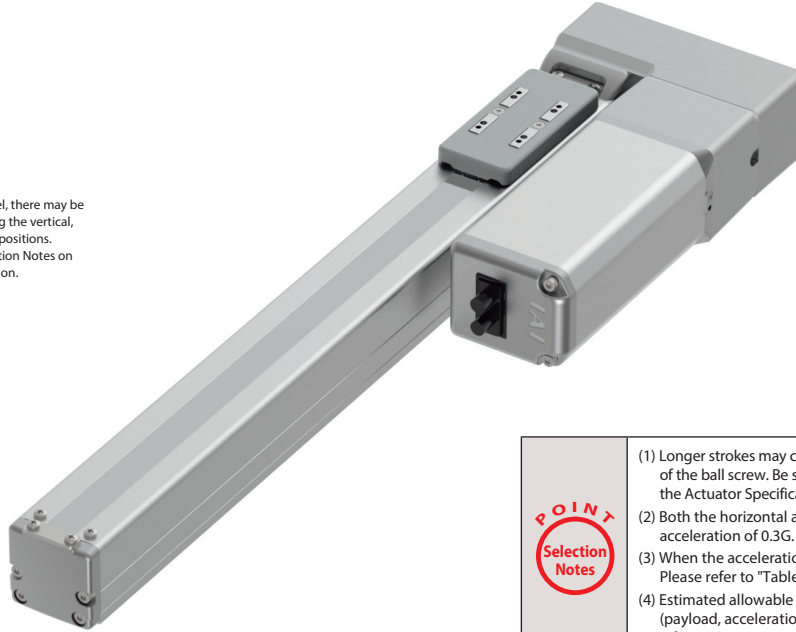

**POINT Selection Notes**

- (1) Longer strokes may cause the maximum speed to decrease due to resonance of the ball screw. Be sure to check the maximum speed of the desired stroke in the Actuator Specifications table, which can be found below.
- (2) Both the horizontal and vertical payloads assume operation at an acceleration of 0.3G.
- (3) When the acceleration is increased, the payload will be reduced. Please refer to "Table of Payload by Acceleration" on P.139 for more details.
- (4) Estimated allowable duty varies depending on operating conditions (payload, acceleration/deceleration, etc.). Please refer to P. 149 for more information.

## Actuator Specifications

### Lead and Payload

Model Number	Motor wattage (W)	Lead (mm)	Max. payload		Rated thrust (N)	Stroke (mm)
			Horizontal (kg)	Vertical (kg)		
RCS4-SA4R-WA-60-16-①-T2-②-③	60	16	10	2.5	53	50~500 (50mm increments)
RCS4-SA4R-WA-60-10-①-T2-②-③		10	14	4.5	85	
RCS4-SA4R-WA-60-5-①-T2-②-③		5	17	8	170	
RCS4-SA4R-WA-60-2.5-①-T2-②-③		2.5	20	12	340	

Legend: ① Stroke ② Cable Length ③ Option

### Stroke and Max Speed (Unit: mm/s)

Lead	Stroke	50~450 (50mm increments)	
		500 (mm)	500 (mm)
16	960	875	
10	600	555	
5	300	275	
2.5	150	135	

### ① Stroke

① Stroke (mm)	RCS4-SA4R	① Stroke (mm)	RCS4-SA4R
50	○	300	○
100	○	350	○
150	○	400	○
200	○	450	○
250	○	500	○

### ② Cable Length

Type	Cable Code
Standard	P(1m)
	S(3m)
	M(5m)
Specified length (Standard cable)	X06(6m) ~X10(10m)
	X11(11m)~X15(15m)
	X16(16m)~X20(20m)
Robot cable	R01(1m) ~R03(3m)
	R04(4m) ~R05(5m)
	R06(6m) ~R10(10m)
	R11(11m)~R15(15m)
	R16(16m)~R20(20m)

### ③ Options

Name	Option Code	Reference Page
Brake	<b>B</b>	See P.131
Cable exit direction (Top)	<b>CJT</b>	See P.131
Cable exit direction (Bottom)	<b>CJB</b>	See P.131
Cable exit direction (Outside)	<b>CJO</b>	See P.131
Motor side-mounted to left (standard)	<b>ML</b>	See P.135
Motor side-mounted to right	<b>MR</b>	See P.135
Non-motor end specification	<b>NM</b>	See P.136
Back mounting plate	<b>RP</b>	See P.137
Slider roller specification	<b>SR</b>	See P.137
Slider spacer	<b>SS</b>	See P.137
Double slider specification (*1)	<b>W</b>	See P.137

(\*1) Some leads cannot be selected. (Please see P. 150)

## Actuator Specifications

Item	Description
Drive system	Ball screw φ8mm, rolled C10
Positioning repeatability	±0.01mm
Lost motion	0.1mm or less
Base	Material: Aluminum with white alumite treatment
Allowable static moment	Ma direction 13.0N·m, Mb direction 18.6N·m, Mc direction 25.3N·m
Allowable dynamic moment (*1)	Ma direction 5.0N·m, Mb direction 7.1N·m, Mc direction 9.7N·m
Ambient operating temp. & humidity	0~40°C, 85% RH or less (Non-condensing)

\* Reference for overhang load length: Ma direction: 150mm or less, Mb, Mc direction: 150mm or less (\*1) Assumes a standard rated life of 5,000km. The running life will vary depending on operation and installation conditions. Please contact IAI America for details of the running life.

See page 146 for moment load directions.

If the moment loads in Ma/Mb/Mc are within the allowable ranges, there is no overhang length limit.

\*1 When the slider is returning to its home position, please be careful of interference from surrounding objects, as it will travel until it reaches the M.E.  
M.E: Mechanical end S.E: Stroke end

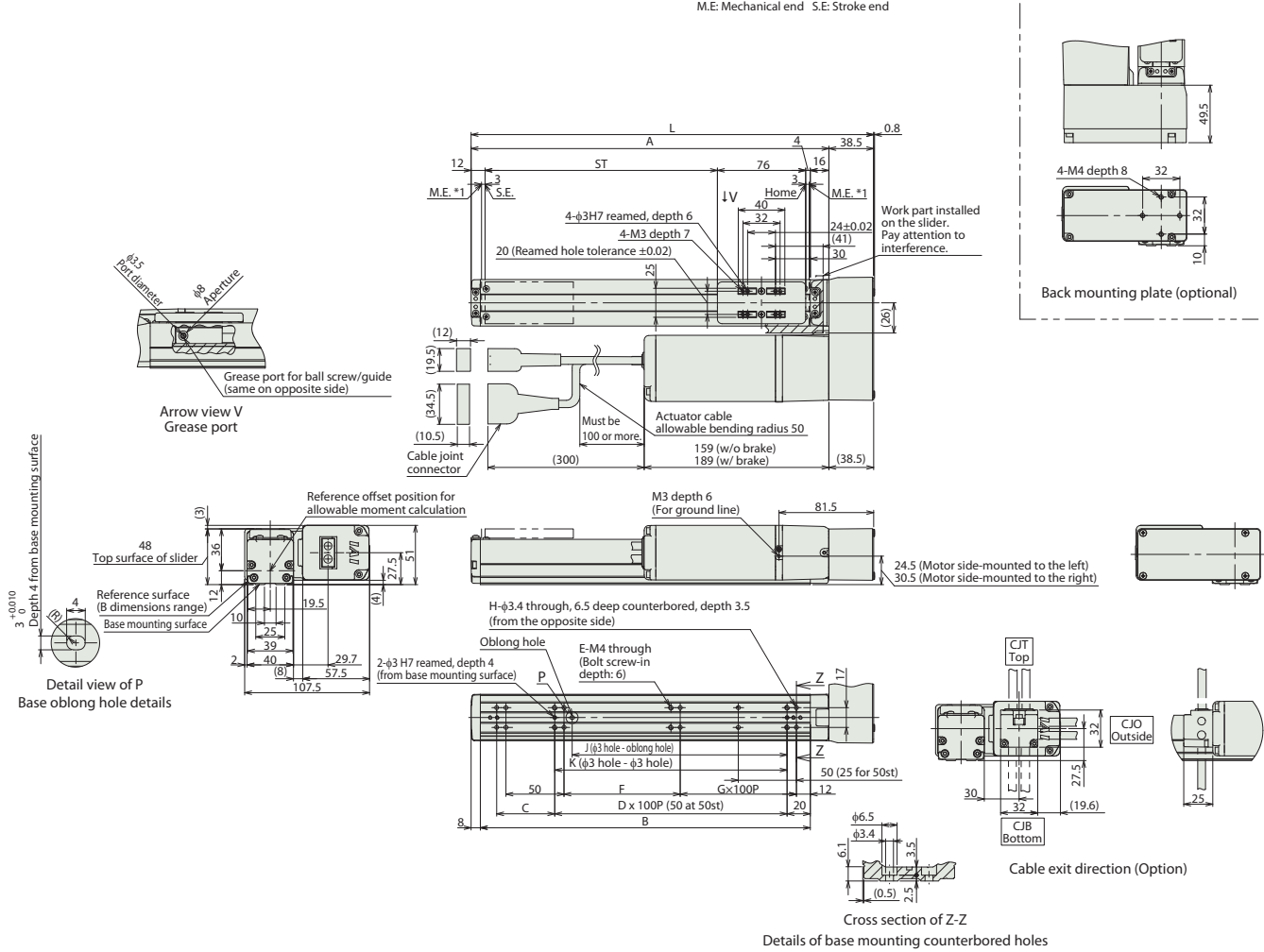

■ Dimensions and Mass by Stroke

Stroke	50	100	150	200	250	300	350	400	450	500	
L	196.5	246.5	296.5	346.5	396.5	446.5	496.5	546.5	596.5	646.5	
A	158	208	258	308	358	408	458	508	558	608	
B	134	184	234	284	334	384	434	484	534	584	
C	50	50	100	50	100	50	100	50	100	50	
D	-	1	1	2	2	3	3	4	4	5	
E	6	6	6	8	8	10	10	12	12	14	
F	50	100	50	100	50	100	50	100	50	100	
G	0	0	1	1	2	2	3	3	4	4	
H	8	8	10	10	12	12	14	14	16	16	
J	35	85	85	185	185	285	285	385	385	485	
K	50	100	100	200	200	300	300	400	400	500	
Mass (kg)	W/o brake	1.5	1.6	1.7	1.7	1.8	1.9	2.0	2.1	2.2	2.3
	W/brake	1.7	1.8	1.9	1.9	2.0	2.1	2.2	2.3	2.4	2.5

Applicable Controllers

The RSC4 series actuators can be operated by the controllers indicated below. Please select the type depending on your intended use.

Name	External view	Max. number of connectable axes	Input power	Control method				Maximum number of positioning points	Reference page	
				Positioner	Pulse train	Program	Network * Option			
SCON-CB/CGB		1	Single phase 100V/200VAC	●	●	-	DeviceNet CC-Link CompoNet MECHATROLINK EtherCAT EtherNet/IP	512 (768 for network spec.)	Please contact IAI for more information.	
SCON-LC/LCG		1		-	-	●		512 (768 for network spec.)		
SCON-CAL/CGAL		1		●	-	-		512 (768 for network spec.)		
MSCON-C		6		This model is network-compatible only.				256		
SSEL-CS		2		●	-	●		20000		
XSEL-P/Q/RA/SA		8	Single phase 200VAC Three-phase 200VAC	-	-	●	55000 (Depending on the type)			

Note: The type of compatible networks will vary depending on the controller. Please refer to the reference page for more information.

Foreword  
Slider Type  
Wide Slider Type  
Rod Type  
Radial Cylinder  
Wide Radial Cylinder  
Table Type  
Cleanroom Slider  
Cleanroom Wide Slider  
Options  
Reference Data  
Controller

# RCS4-SA6R



Model Specification Items	<b>RCS4</b> — <b>SA6R</b> — <b>WA</b> — <b>100</b> — [ ] — [ ] — [ ] — [ ] — [ ] — [ ]	<b>T2</b> — [ ] — [ ]	* Body width does not include the width of the side-mounted motor.					
Series	Type	Encoder Type	Motor Type	Lead	Stroke	Applicable Controllers	Cable Length	Options
WA: Battery-less Absolute	100: Servo motor 100W	30:30mm 20:20mm 12:12mm 6: 6mm 3: 3mm	50:50mm 800:800mm (50mm increments)	T2:SCON MSCON SSEL XSEL-P/Q XSEL-RA/SA	N : None P : 1m S : 3m M : 5m X [ ] : Specified Length R [ ] : Robot Cable	Refer to Options table below.		

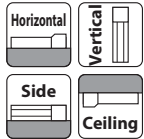

\* Depending on the model, there may be some limitations to using the vertical, side, and ceiling mount positions. Please refer to the Selection Notes on P.138 for more information.

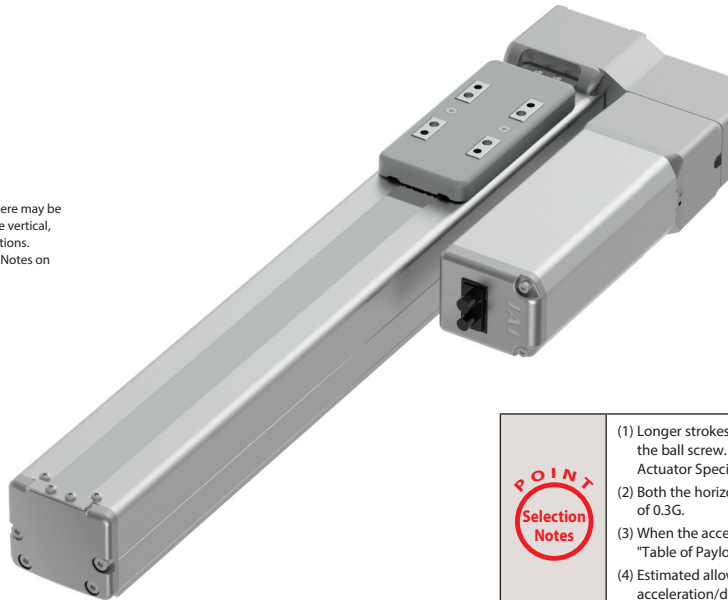

- (1) Longer strokes may cause the maximum speed to decrease due to resonance of the ball screw. Be sure to check the maximum speed of the desired stroke in the Actuator Specifications table, which can be found below.
- (2) Both the horizontal and vertical payloads assume operation at an acceleration of 0.3G.
- (3) When the acceleration is increased, the payload will be reduced. Please refer to "Table of Payload by Acceleration" on P.139 for more details.
- (4) Estimated allowable duty varies depending on operating conditions (payload, acceleration/deceleration, etc.). Please refer to P. 149 for more information.

## Actuator Specifications

### Lead and Payload

Model Number	Motor wattage (W)	Lead (mm)		Rated thrust (N)	Stroke (mm)
		Horizontal (kg)	Vertical (kg)		
RCS4-SA6R-WA-100-30-①-T2-②-③	100	30	11	57	50~800 (50mm increments)
RCS4-SA6R-WA-100-20-①-T2-②-③		20	18	85	
RCS4-SA6R-WA-100-12-①-T2-②-③		12	30	142	
RCS4-SA6R-WA-100-6-①-T2-②-③		6	45	283	
RCS4-SA6R-WA-100-3-①-T2-②-③		3	45	566	

Legend: ① Stroke ② Cable Length ③ Option

### Stroke and Max Speed

(Unit: mm/s)

Stroke Lead	Stroke (mm)						
	50~500 (50mm increments)	550 (mm)	600 (mm)	650 (mm)	700 (mm)	750 (mm)	800 (mm)
30	1600	1450	1260	1100	970	860	
20	1200	1130	970	840	735	650	575
12	720	620	535	460	405	355	315
6	360	305	265	230	200	175	155
3	180	150	130	115	100	85	75

### ① Stroke

① Stroke (mm)	RCS4-SA6R	① Stroke (mm)	RCS4-SA6R
50	○	450	○
100	○	500	○
150	○	550	○
200	○	600	○
250	○	650	○
300	○	700	○
350	○	750	○
400	○	800	○

### ② Cable Length

Type	Cable Code
Standard	P(1m)
	S(3m)
	M(5m)
Specified length (Standard cable)	X06(6m) ~ X10(10m)
	X11(11m) ~ X15(15m)
	X16(16m) ~ X20(20m)
Robot cable	R01(1m) ~ R03(3m)
	R04(4m) ~ R05(5m)
	R06(6m) ~ R10(10m)
	R11(11m) ~ R15(15m)
	R16(16m) ~ R20(20m)

### ③ Options

Name	Option Code	Reference Page
Brake	B	See P.131
Cable exit direction (Top)	CJT	See P.131
Cable exit direction (Bottom)	CJB	See P.131
Cable exit direction (Outside)	CJO	See P.131
Motor side-mounted to left (standard)	ML	See P.135
Motor side-mounted to right	MR	See P.135
Non-motor end specification	NM	See P.136
Slider roller specification	SR	See P.137
Double slider specification (*1)	W	See P.137

(\*1) Some leads cannot be selected. (Please see P. 150)

### Actuator Specifications

Item	Description
Drive system	Ball screw φ10mm, rolled C10
Positioning repeatability	±0.01mm
Lost motion	0.1 mm or less
Base	Material: Aluminum with white alumite treatment
Allowable static moment	Ma direction: 48.5N·m, Mb direction: 69.3N·m, Mc direction: 103N·m
Allowable dynamic moment (*1)	Ma direction: 11.6N·m, Mb direction: 16.6N·m, Mc direction: 24.6N·m
Ambient operating temp. & humidity	0~40°C, 85% RH or less (Non-condensing)

\* Reference for overhang load length: Ma direction: 220mm or less, Mb, Mc direction: 220mm or less

(\*1) Assumes a standard rated life of 5,000km. The running life will vary depending on operation and installation conditions. Please contact IAI America for details of the running life. See page 146 for moment load directions. If the moment loads in Ma/Mb/Mc are within the allowable ranges, there is no overhang length limit.



\*1 When the slider is returning to its home position, please be careful of interference from surrounding objects, as it will travel until it reaches the M.E.  
M.E: Mechanical end S.E: Stroke end

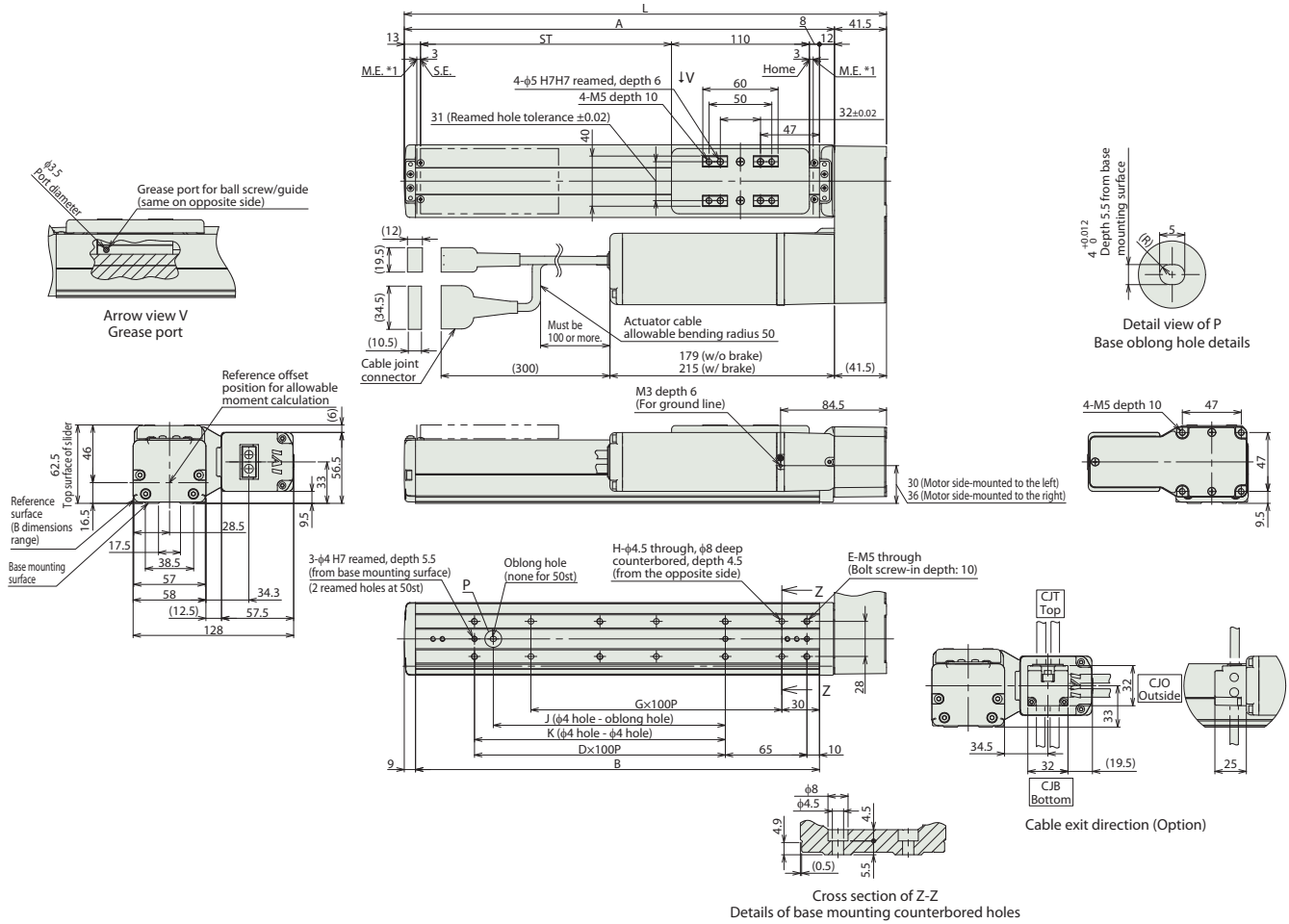

■ Dimensions and Mass by Stroke

Stroke	50	100	150	200	250	300	350	400	450	500	550	600	650	700	750	800	
L	234.5	284.5	334.5	384.5	434.5	484.5	534.5	584.5	634.5	684.5	734.5	784.5	834.5	884.5	934.5	984.5	
A	193	243	293	343	393	443	493	543	593	643	693	743	793	843	893	943	
B	172	222	272	322	372	422	472	522	572	622	672	722	772	822	872	922	
D	0	1	1	2	2	3	3	4	4	5	5	6	6	7	7	8	
E	4	6	6	8	8	10	10	12	12	14	14	16	16	18	18	20	
G	1	1	2	2	3	3	4	4	5	5	6	6	7	7	8	8	
H	4	4	6	6	8	8	10	10	12	12	14	14	16	16	18	18	
J	0	85	85	185	185	285	285	385	385	485	485	585	585	685	685	785	
K	0	100	100	200	200	300	300	400	400	500	500	600	600	700	700	800	
Mass (kg)	W/o brake	2.4	2.5	2.7	2.9	3.1	3.2	3.4	3.6	3.8	4.0	4.1	4.3	4.5	4.7	4.9	5.0
	W/brake	2.7	2.8	3.0	3.2	3.4	3.5	3.7	3.9	4.1	4.3	4.4	4.6	4.8	5.0	5.2	5.3

Applicable Controllers

The R4S series actuators can be operated by the controllers indicated below. Please select the type depending on your intended use.

Name	External view	Max. number of connectable axes	Input power	Control method				Maximum number of positioning points	Reference page	
				Positioner	Pulse train	Program	Network * Option			
SCON-CB/CGB		1	Single phase 100V/200VAC	●	●	—	DeviceNet CC-Link CompoNet MECHATROLINK EtherCAT EtherNet/IP	512 (768 for network spec.)	Please contact IAI for more information.	
SCON-LC/LCG		1		—	—	●		512 (768 for network spec.)		
SCON-CAL/CGAL		1		●	—	—		512 (768 for network spec.)		
MSCON-C		6		This model is network-compatible only.				256		
SSEL-CS		2		●	—	●		20000		
XSEL-P/Q/RA/SA		8	Single phase 200VAC Three-phase 200VAC	—	—	●	55000 (Depending on the type)			

Note: The type of compatible networks will vary depending on the controller. Please refer to the reference page for more information.

Foreword  
Slider Type  
Wide Slider Type  
Rod Type  
Radial Cylinder  
Wide Radial Cylinder  
Table Type  
Cleanroom Slider  
Cleanroom Wide Slider  
Options  
Reference Data  
Controller

# RCS4-SA7R



## Model Specification Items

<b>RCS4</b>	<b>SA7R</b>	<b>WA</b>	<b>200</b>			<b>T2</b>			
Series	Type	Encoder Type	Motor Type	Lead	Stroke	Applicable Controllers	Cable Length	Options	
		WA: Battery-less Absolute	200: Servo motor 200W	36:36mm 24:24mm 16:16mm 8: 8mm 4: 4mm	50:50mm 800:800mm (50mm increments)	T2:SCON MSCON SSEL XSEL-P/Q XSEL-RA/SA	N : None P : 1m S : 3m M : 5m	X□□ : Specified Length R□□ : Robot Cable	* Body width does not include the width of the side-mounted motor.

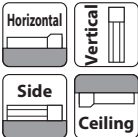

\* Depending on the model, there may be some limitations to using the vertical, side, and ceiling mount positions. Please refer to the Selection Notes on P.138 for more information.

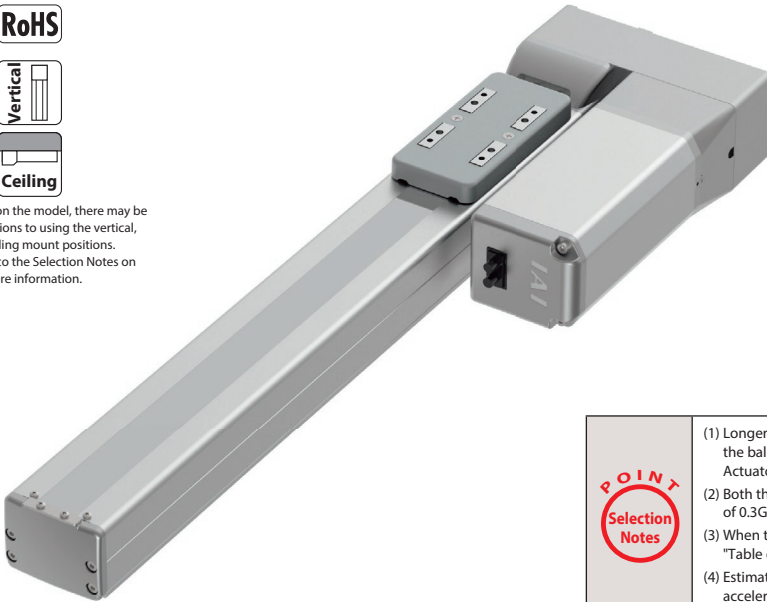

- POINT Selection Notes**
- (1) Longer strokes may cause the maximum speed to decrease due to resonance of the ball screw. Be sure to check the maximum speed of the desired stroke in the Actuator Specifications table, which can be found below.
  - (2) Both the horizontal and vertical payloads assume operation at an acceleration of 0.3G.
  - (3) When the acceleration is increased, the payload will be reduced. Please refer to "Table of Payload by Acceleration" on P.139 for more details.
  - (4) Estimated allowable duty varies depending on operating conditions (payload, acceleration/deceleration, etc.). Please refer to P. 149 for more information.

## Actuator Specifications

### Lead and Payload

Model Number	Motor wattage (W)	Lead (mm)	Max. payload (kg)	Rated thrust (N)	Stroke (mm)
RCS4-SA7R-WA-200-36-①-T2-②-③	200	36	7	4	50~800 (50mm increments)
RCS4-SA7R-WA-200-24-①-T2-②-③		24	30	6	
RCS4-SA7R-WA-200-16-①-T2-②-③		16	38	12	
RCS4-SA7R-WA-200-8-①-T2-②-③		8	45	18	
RCS4-SA7R-WA-200-4-①-T2-②-③		4	50	25	

Legend: ① Stroke ② Cable Length ③ Option

### Stroke and Max Speed

(Unit: mm/s)

Stroke / Lead	Stroke (mm)						
	50~500 (50mm increments)	550	600	650	700	750	800
36	1800			1620	1420	1260	1120
24	1500	1440	1240	1095	965	850	760
16	1000	965	830	720	635	560	500
8	500	475	410	355	315	275	245
4	240	235	205	175	155	135	120

### ① Stroke

① Stroke (mm)	RCS4-SA7R	① Stroke (mm)	RCS4-SA7R
50	○	450	○
100	○	500	○
150	○	550	○
200	○	600	○
250	○	650	○
300	○	700	○
350	○	750	○
400	○	800	○

### ② Cable Length

Type	Cable Code
Standard	P(1m)
	S(3m)
	M(5m)
Specified length (Standard cable)	X06(6m) ~ X10(10m)
	X11(11m) ~ X15(15m)
	X16(16m) ~ X20(20m)
Robot cable	R01(1m) ~ R03(3m)
	R04(4m) ~ R05(5m)
	R06(6m) ~ R10(10m)
	R11(11m) ~ R15(15m)
	R16(16m) ~ R20(20m)

### ③ Options

Name	Option Code	Reference Page
Brake	<b>B</b>	See P.131
Cable exit direction (Top)	<b>CJT</b>	See P.131
Cable exit direction (Bottom)	<b>CJB</b>	See P.131
Cable exit direction (Outside)	<b>CJO</b>	See P.131
Motor side-mounted to left (standard)	<b>ML</b>	See P.135
Motor side-mounted to right	<b>MR</b>	See P.135
Non-motor end specification	<b>NM</b>	See P.136
Slider roller specification	<b>SR</b>	See P.137
Slider spacer	<b>SS</b>	See P.137
Double slider specification (*1)	<b>W</b>	See P.137

(\*1) Some leads cannot be selected. (Please see P. 150)

## Actuator Specifications

Item	Description
Drive system	Ball screw φ12mm, rolled C10
Positioning repeatability	±0.01mm
Lost motion	0.1 mm or less
Base	Material: Aluminum with white alumite treatment
Allowable static moment	Ma direction 115N·m, Mb direction 115N·m, Mc direction 229N·m
Allowable dynamic moment (*1)	Ma direction 44.7N·m, Mb direction 44.7N·m, Mc direction 89.1N·m
Ambient operating temp. & humidity	0~40°C, 85% RH or less (Non-condensing)

\* Reference for overhang load length: Ma direction: 300mm or less, Mb, Mc direction: 300mm or less

(\*1) Assumes a standard rated life of 5,000km. The running life will vary depending on operation and installation conditions. Please contact IAI America for details of the running life. See page 146 for moment load directions. If the moment loads in Ma/Mb/Mc are within the allowable ranges, there is no overhang length limit.





\*1 When the slider is returning to its home position, please be careful of interference from surrounding objects, as it will travel until it reaches the M.E.  
M.E: Mechanical end S.E: Stroke end

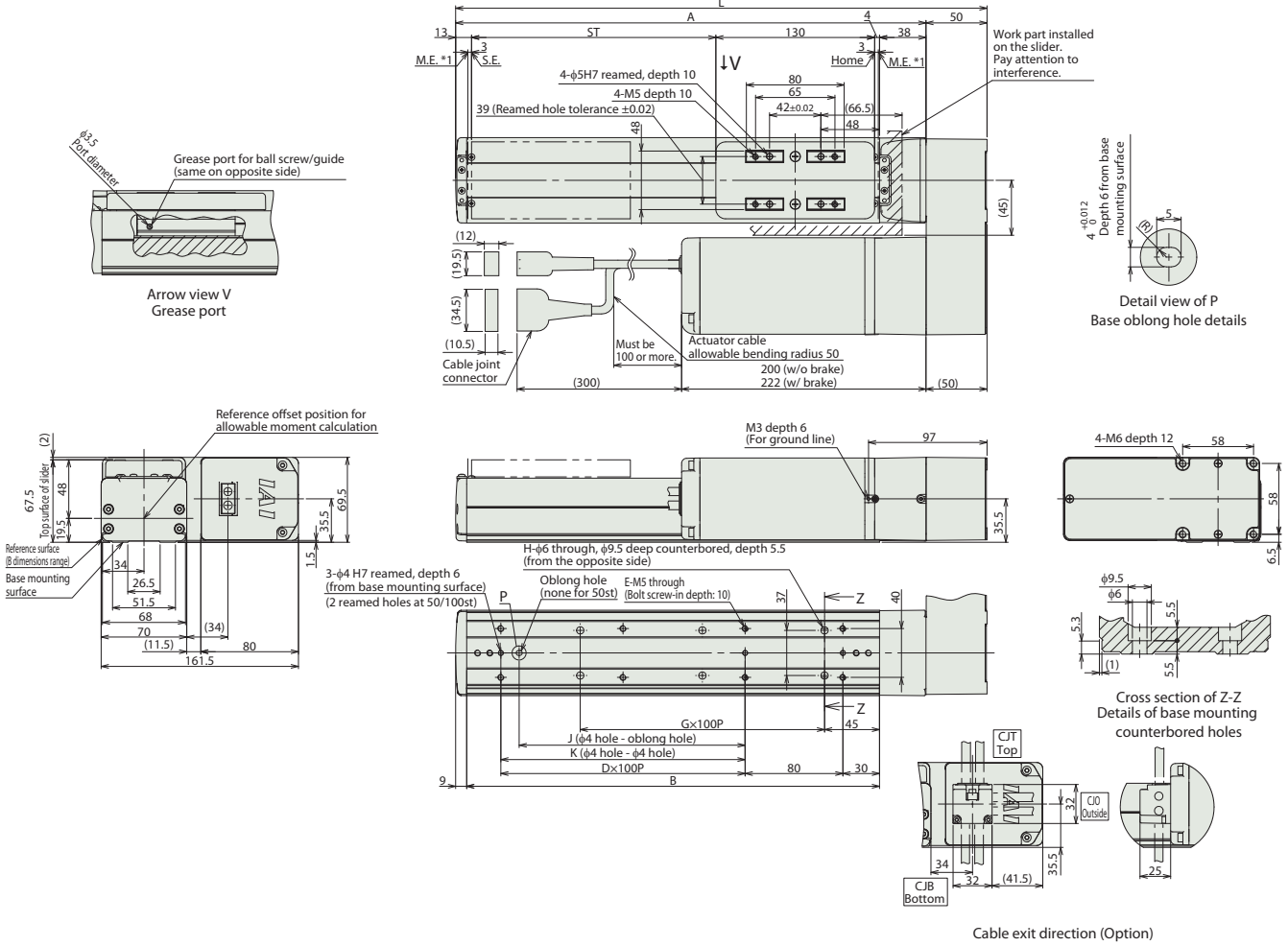

Foreword  
Slider Type  
Wide Slider Type  
Rod Type  
Radial Cylinder  
Wide Radial Cylinder  
Table Type  
Cleanroom Slider  
Cleanroom Wide Slider  
Options  
Reference Data  
Controller

■ Dimensions and Mass by Stroke

Stroke	50	100	150	200	250	300	350	400	450	500	550	600	650	700	750	800	
L	285	335	385	435	485	535	585	635	685	735	785	835	885	935	985	1035	
A	235	285	335	385	435	485	535	585	635	685	735	785	835	885	935	985	
B	188	238	288	338	388	438	488	538	588	638	688	738	788	838	888	938	
D	0	1	1	2	2	3	3	4	4	5	5	6	6	7	7	8	
E	4	6	6	8	8	10	10	12	12	14	14	16	16	18	18	20	
G	1	1	2	2	3	3	4	4	5	5	6	6	7	7	8	8	
H	4	4	6	6	8	8	10	10	12	12	14	14	16	16	18	18	
J	0	85	85	185	185	285	285	385	385	485	485	585	585	685	685	785	
K	0	0	100	200	200	300	300	400	400	500	500	600	600	700	700	800	
Mass (kg)	W/o brake	4.3	4.6	4.8	5.0	5.3	5.5	5.8	6.0	6.2	6.5	6.7	6.9	7.2	7.4	7.6	7.9
	W/ brake	4.8	5.1	5.3	5.5	5.8	6.0	6.3	6.5	6.7	7.0	7.2	7.4	7.7	7.9	8.1	8.4

Applicable Controllers

The RCS4 series actuators can be operated by the controllers indicated below. Please select the type depending on your intended use.

Name	External view	Max. number of connectable axes	Input power	Control method				Maximum number of positioning points	Reference page	
				Positioner	Pulse train	Program	Network * Option			
SCON-CB/CGB		1	Single phase 100V/200VAC	●	●	—	DeviceNet CC-Link CC-Link IE CompoNet MECHATROLINK EtherCAT EtherNet/IP CC-Link IE FS	512 (768 for network spec.)	Please contact IAI for more information.	
SCON-LC/LCG		1		—	—	●		512 (768 for network spec.)		
SCON-CAL/CGAL		1		—	—	—		512 (768 for network spec.)		
MSCON-C		6		This model is network-compatible only.				256		
SSEL-CS		2		●	—	●		20000		
XSEL-P/Q/RA/SA		8	Single phase 200VAC Three-phase 200VAC	—	—	●	55000 (Depending on the type)			

Note:  
The type of compatible networks will vary depending on the controller. Please refer to the reference page for more information.

# RCS4-SA8R



Model Specification Items	<b>RCS4</b> — <b>SA8R</b> — <b>WA</b> — <b>400</b>	<b>T2</b>								
	Series — Type — Encoder Type — Motor Type — Lead — Stroke — Applicable Controllers — Cable Length — Options									* Body width does not include the width of the side-mounted motor.
	WA: Battery-less Absolute 400: Servo motor 400W	T2: SCON SSEL XSEL-P/Q XSEL-RA/SA	48: 48mm 30: 30mm 20: 20mm 10: 10mm 5: 5mm	50: 50mm 1100: 1100mm (50mm increments)	N : None P : 1m S : 3m M : 5m	X□ : Specified Length R□ : Robot Cable				Refer to Options table below.

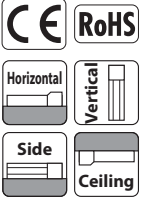

\* Depending on the model, there may be some limitations to using the vertical, side, and ceiling mount positions. Please refer to the Selection Notes on P.138 for more information.

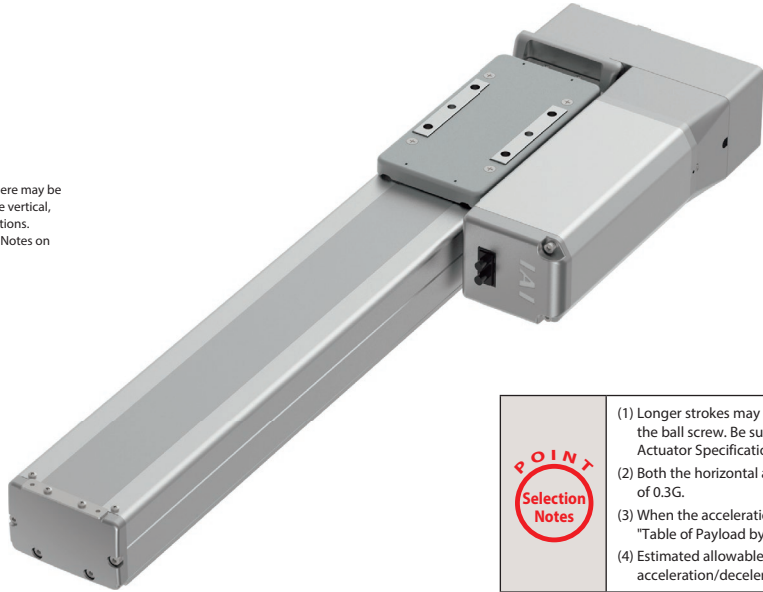

- POINT Selection Notes**
- (1) Longer strokes may cause the maximum speed to decrease due to resonance of the ball screw. Be sure to check the maximum speed of the desired stroke in the Actuator Specifications table, which can be found below.
  - (2) Both the horizontal and vertical payloads assume operation at an acceleration of 0.3G.
  - (3) When the acceleration is increased, the payload will be reduced. Please refer to "Table of Payload by Acceleration" on P.139 for more details.
  - (4) Estimated allowable duty varies depending on operating conditions (payload, acceleration/deceleration, etc.). Please refer to P. 149 for more information.

## Actuator Specifications

### Lead and Payload

Model Number	Motor wattage (W)	Lead (mm)	Max. payload		Rated thrust (N)	Stroke (mm)
			Horizontal (kg)	Vertical (kg)		
RCS4-SA8R-WA-400-48-①-T2-②-③	400	48	8	-	141	50~1100 (50mm increments)
RCS4-SA8R-WA-400-30-①-T2-②-③		30	30	12	226	
RCS4-SA8R-WA-400-20-①-T2-②-③		20	60	20	339	
RCS4-SA8R-WA-400-10-①-T2-②-③		10	80	35	678	
RCS4-SA8R-WA-400-5-①-T2-②-③		5	90	45	1357	

### Stroke and Max Speed

(Unit: mm/s)

Stroke	Stroke (mm)										
	50~600 (50mm increments)	650	700	750	800	850	900	950	1000	1050	1100
48	2100			1950	1760	1590	1450	1320	1210	1110	
30	1800	1640	1440	1280	1155	1040	940	855	780	715	660
20	1200	1090	960	860	770	695	630	570	520	480	440
10	600	540	480	430	385	345	310	285	260	235	220
5	300	270	240	215	190	175	155	140	130	120	110

Legend: ① Stroke ② Cable Length ③ Option

### ① Stroke

① Stroke (mm)	RCS4-SA8R	① Stroke (mm)	RCS4-SA8R
50	○	600	○
100	○	650	○
150	○	700	○
200	○	750	○
250	○	800	○
300	○	850	○
350	○	900	○
400	○	950	○
450	○	1000	○
500	○	1050	○
550	○	1100	○

### ② Cable Length

Type	Cable Code
Standard	P(1m) S(3m) M(5m)
	X06(6m) ~ X10(10m) X11(11m) ~ X15(15m) X16(16m) ~ X20(20m)
	R01(1m) ~ R03(3m) R04(4m) ~ R05(5m) R06(6m) ~ R10(10m) R11(11m) ~ R15(15m) R16(16m) ~ R20(20m)

### ③ Options

Name	Option Code	Reference Page
Brake	<b>B</b>	See P.131
Cable exit direction (Top)	<b>CJT</b>	See P.131
Cable exit direction (Bottom)	<b>CJB</b>	See P.131
Cable exit direction (Outside)	<b>CJO</b>	See P.131
Motor side-mounted to left (standard)	<b>ML</b>	See P.135
Motor side-mounted to right	<b>MR</b>	See P.135
Non-motor end specification	<b>NM</b>	See P.136
Slider roller specification	<b>SR</b>	See P.137
Slider spacer	<b>SS</b>	See P.137
Double slider specification (*1)	<b>W</b>	See P.137

(\*1) Some leads cannot be selected. (Please see P. 150)

### Actuator Specifications

Item	Description
Drive system	Ball screw $\phi$ 16mm, rolled C10
Positioning repeatability	$\pm$ 0.01mm
Lost motion	0.1mm or less
Base	Material: Aluminum with white alumite treatment
Allowable static moment	Ma direction 219N·m, Mb direction 219N·m, Mc direction 414N·m
Allowable dynamic moment (*1)	Ma direction 77.0N·m, Mb direction 77.0N·m, Mc direction 146N·m
Ambient operating temp. & humidity	0~40°C, 85% RH or less (Non-condensing)

\* Reference for overhang load length: Ma direction: 400mm or less, Mb, Mc direction: 400mm or less

(\*1) Assumes a standard rated life of 5,000km. The running life will vary depending on operation and installation conditions. Please contact IAI America for details of the running life.

See page 146 for moment load directions. If the moment loads in Ma/Mb/Mc are within the allowable ranges, there is no overhang length limit.



\*1 When the slider is returning to its home position, please be careful of interference from surrounding objects, as it will travel until it reaches the M.E.  
M.E: Mechanical end S.E: Stroke end

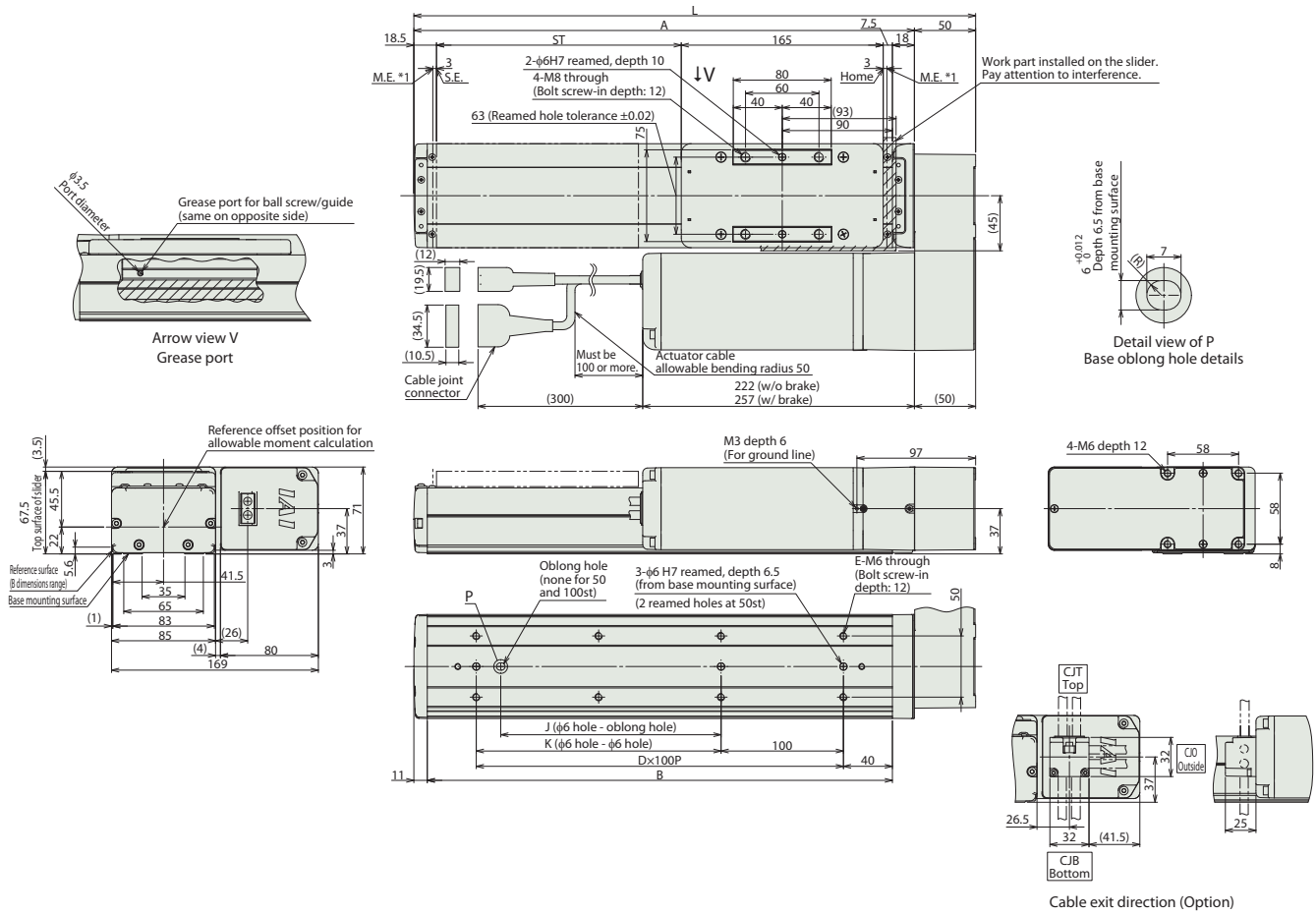

**Dimensions and Mass by Stroke**

Stroke	50	100	150	200	250	300	350	400	450	500	550	600	650	700	750	800	850	900	950	1000	1050	1100	
L	309	359	409	459	509	559	609	659	709	759	809	859	909	959	1009	1059	1109	1159	1209	1259	1309	1359	
A	259	309	359	409	459	509	559	609	659	709	759	809	859	909	959	1009	1059	1109	1159	1209	1259	1309	
B	230	280	330	380	430	480	530	580	630	680	730	780	830	880	930	980	1030	1080	1130	1180	1230	1280	
D	1	2	3	3	3	3	4	4	5	5	6	6	7	7	8	8	9	9	10	10	11	12	
E	4	6	6	8	8	10	10	12	12	14	14	16	16	18	18	20	20	22	22	24	24	26	
J	0	0	80	180	180	280	280	380	380	480	480	580	580	680	680	780	780	880	880	980	980	1080	
K	0	100	100	200	200	300	300	400	400	500	500	600	600	700	700	800	800	900	900	1000	1000	1100	
Mass (kg)	W/o brake	5.6	5.9	6.2	6.4	6.7	7.0	7.3	7.6	7.9	8.2	8.5	8.8	9.1	9.4	9.6	9.9	10.2	10.5	10.8	11.1	11.4	11.7
	W/ brake	6.1	6.4	6.7	6.9	7.2	7.5	7.8	8.1	8.4	8.7	9.0	9.3	9.6	9.9	10.1	10.4	10.7	11.0	11.3	11.6	11.9	12.2

**Applicable Controllers**

The RCS4 series actuators can be operated by the controllers indicated below. Please select the type depending on your intended use.

Name	External view	Max. number of connectable axes	Input power	Control method				Maximum number of positioning points	Reference page
				Positioner	Pulse train	Program	Network * Option		
SCON-CB/CGB		1	Single phase 200VAC	●	●	-	<b>DeviceNet</b> <b>CC-Link</b> <b>CompoNet</b> <b>MECHATROLINK</b> <b>EtherCAT</b> <b>EtherNet/IP</b> Note: The type of compatible networks will vary depending on the controller. Please refer to the reference page for more information.	512 (768 for network spec.)	Please contact IAI for more information.
SCON-LC/LCG		1		-	-	●		512 (768 for network spec.)	
SSEL-CS		2	Single phase 100V/200VAC	●	-	●		20000	
XSEL-P/Q/RA/SA		8	Single phase 200VAC Three-phase 200VAC	-	-	●		55000 (Depending on the type)	

# RCS4-WSA10C



## Model Specification Items

<b>RCS4</b> — <b>WSA10C</b> — <b>WA</b> — <b>60</b> — <input type="checkbox"/> — <input type="checkbox"/> — <b>T2</b> — <input type="checkbox"/> — <input type="checkbox"/>
Series — Type — Encoder Type — Motor Type — Lead — Stroke — Applicable Controllers — Cable Length — Options
WA: Battery-less Absolute      60: Servo motor 60W      16: 16mm 10: 10mm 5: 5mm 2.5: 2.5mm      50: 50mm 500: 500mm (50mm increments)
T2: SCON MSCON SSEL XSEL-P/Q XSEL-RA/SA      N : None P : 1m S : 3m M : 5m X□□ : Specified Length R□□ : Robot Cable
Refer to Options table below. * Be sure to select an option for the cable exit direction.

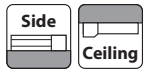

\* Depending on the model, there may be some limitations to using the vertical, side, and ceiling mount positions. Please refer to the Selection Notes on P.138 for more information.

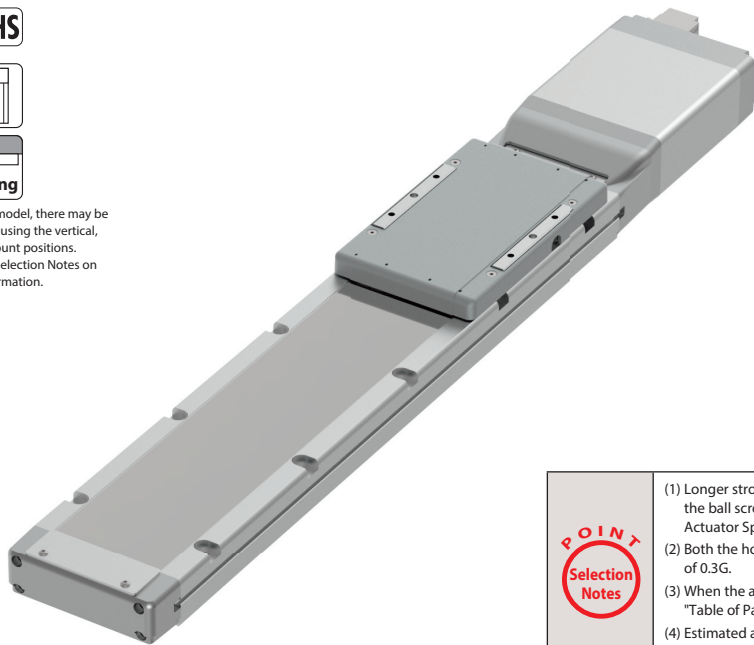

- POINT Selection Notes**
- Longer strokes may cause the maximum speed to decrease due to resonance of the ball screw. Be sure to check the maximum speed of the desired stroke in the Actuator Specifications table, which can be found below.
  - Both the horizontal and vertical payloads assume operation at an acceleration of 0.3G.
  - When the acceleration is increased, the payload will be reduced. Please refer to "Table of Payload by Acceleration" on P.139 for more details.
  - Estimated allowable duty varies depending on operating conditions (payload, acceleration/deceleration, etc.). Please refer to P. 149 for more information.

## Actuator Specifications

### Lead and Payload

Model Number	Motor wattage (W)	Lead (mm)	Max. payload		Rated thrust (N)	Stroke (mm)
			Horizontal (kg)	Vertical (kg)		
RCS4-WSA10C-WA-60-16-①-T2-②-③	60	16	7	—	53	50~500 (50mm increments)
RCS4-WSA10C-WA-60-10-①-T2-②-③		10	16	3	85	
RCS4-WSA10C-WA-60-5-①-T2-②-③		5	27	5	170	
RCS4-WSA10C-WA-60-2.5-①-T2-②-③		2.5	40	10	340	

Legend: ① Stroke ② Cable Length ③ Option

### Stroke and Max Speed

(Unit: mm/s)

Lead	Stroke	50~350 (50mm increments)			
		400 (mm)	450 (mm)	500 (mm)	
16	16	960	930	775	660
10	10	600	590	490	415
5	5	300	290	245	205
2.5	2.5	150	145	120	100

### ① Stroke

① Stroke (mm)	RCS4-WSA10C	① Stroke (mm)	RCS4-WSA10C
50	○	300	○
100	○	350	○
150	○	400	○
200	○	450	○
250	○	500	○

### ② Cable Length

Type	Cable Code
Standard	P(1m)
	S(3m)
	M(5m)
Specified length (Standard cable)	X06(6m) ~ X10(10m)
	X11(11m) ~ X15(15m)
	X16(16m) ~ X20(20m)
Robot cable	R01(1m) ~ R03(3m)
	R04(4m) ~ R05(5m)
	R06(6m) ~ R10(10m)
	R11(11m) ~ R15(15m)
	R16(16m) ~ R20(20m)
	R20(20m)

### ③ Options

Name	Option Code	Reference Page
Brake	B	See P.131
Cable exit direction (Top)	CJT	See P.131
Cable exit direction (Right)	CJR	See P.131
Cable exit direction (Left)	CJL	See P.131
Cable exit direction (Bottom)	CJB	See P.131
High-precision specification	HPR	See P.134
Non-motor end specification	NM	See P.136
Slider roller specification	SR	See P.137

### Actuator Specifications

Item	Description
Drive system	Ball screw φ8mm, rolled C10
Positioning repeatability (*1)	±0.01mm [±0.005mm]
Lost motion	0.1mm or less
Base	Material: Aluminum with white alumite treatment
Allowable static moment	Ma direction 271N·m, Mb direction 271N·m, Mc direction 553N·m
Allowable dynamic moment (*2)	Ma direction 65.4N·m, Mb direction 65.4N·m, Mc direction 134N·m
Ambient operating temp. & humidity	0~40°C, 85% RH or less (Non-condensing)

\* Reference for overhang load length: Ma direction: 500mm or less, Mb, Mc direction: 500mm or less

(\*1) Values in [ ] are for high precision specification.

(\*2) Assumes a standard rated life of 5,000km. The running life will vary depending on operation and installation conditions. Please contact IAI America for details of the running life.

See page 146 for moment load directions.

If the moment loads in Ma/Mb/Mc are within the allowable ranges, there is no overhang length limit.



\*1 When the slider is returning to its home position, please be careful of interference from surrounding objects, as it will travel until it reaches the M.E.  
M.E: Mechanical end S.E: Stroke end

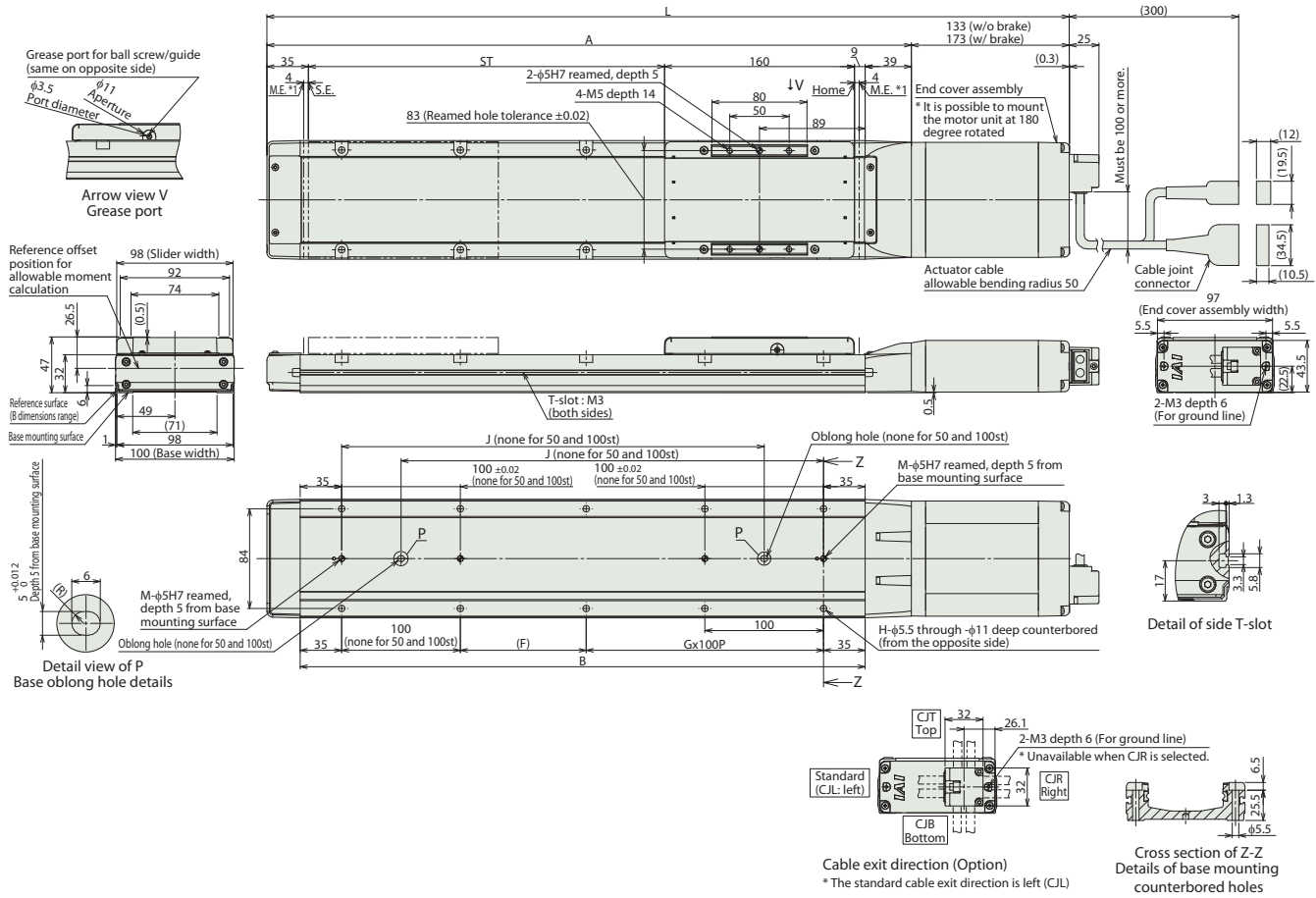

■ Dimensions and Mass by Stroke

Stroke	Stroke										
	50	100	150	200	250	300	350	400	450	500	
L	W/o brake	426	476	526	576	626	676	726	776	826	876
	W/ brake	466	516	566	616	666	716	766	816	866	916
A	293	343	393	443	493	543	593	643	693	743	
B	226	276	326	376	426	476	526	576	626	676	
F	156	206	256	306	356	406	456	506	556	606	
G	0	0	1	1	2	2	3	3	4	4	
H	4	4	8	8	10	10	12	12	14	14	
J	-	-	206	256	306	356	406	456	506	556	
M	1	1	2	2	2	2	2	2	2	2	
Mass (kg)	W/o brake	2.8	3.0	3.3	3.5	3.8	4.0	4.3	4.5	4.8	5.0
	W/ brake	3.1	3.3	3.6	3.8	4.1	4.3	4.6	4.8	5.1	5.3

Applicable Controllers

The RCS4 series actuators can be operated by the controllers indicated below. Please select the type depending on your intended use.

Name	External view	Max. number of connectable axes	Input power	Control method				Maximum number of positioning points	Reference page	
				Positioner	Pulse train	Program	Network * Option			
SCON-CB/CGB		1	Single phase 100V/200VAC	●	●	-	DeviceNet CC-Link CC-Link IE CompoNet MECHATROLINK EtherCAT EtherNet/IP CC-Link IE FS	512 (768 for network spec.)	Please contact IAI for more information.	
SCON-LC/LCG		1		-	-	●		512 (768 for network spec.)		
SCON-CAL/CGAL		1		●	-	-		512 (768 for network spec.)		
MSCON-C		6		This model is network-compatible only.				256		
SSEL-CS		2		●	-	●		20000		
XSEL-P/Q/RA/SA		8		Single phase 200VAC Three-phase 200VAC	-	-		●		55000 (Depending on the type)

Note:  
The type of compatible networks will vary depending on the controller. Please refer to the reference page for more information.

# RCS4-WSA12C



## Model Specification Items

**RCS4** — **WSA12C** — **WA** — **100** —  —  — **T2** —  —

Series — Type — Encoder Type — Motor Type — Lead — Stroke — Applicable Controllers — Cable Length — Options

WA: Battery-less Absolute

100: Servo motor 100W

30:30mm  
20:20mm  
12:12mm  
6: 6mm  
3: 3mm

50:50mm  
800:800mm  
(50mm increments)

T2:SCON  
MSCON  
SSEL  
XSEL-P/Q  
XSEL-RA/SA

N : None  
P : 1m  
S : 3m  
M : 5m  
X : Specified Length  
R : Robot Cable

Refer to Options table below.  
\* Be sure to select an option for the cable exit direction.

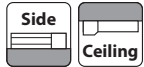

\* Depending on the model, there may be some limitations to using the vertical, side, and ceiling mount positions. Please refer to the Selection Notes on P.138 for more information.

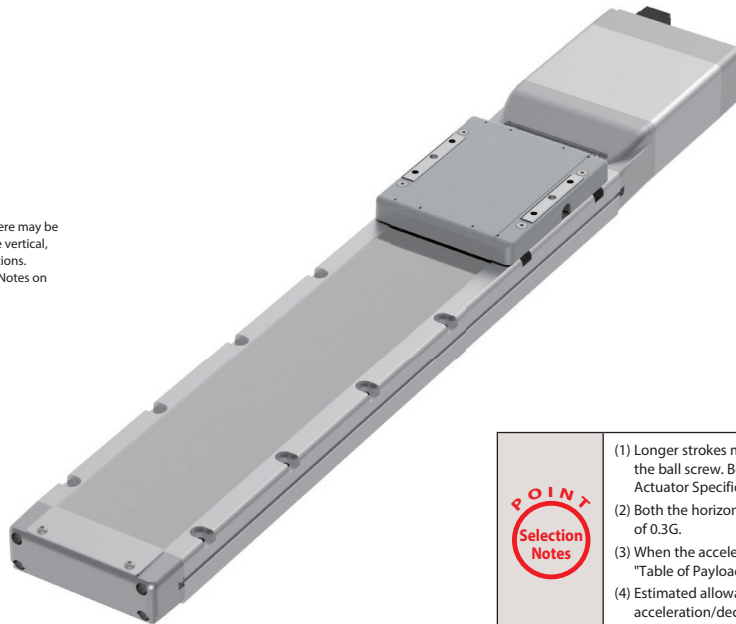

- (1) Longer strokes may cause the maximum speed to decrease due to resonance of the ball screw. Be sure to check the maximum speed of the desired stroke in the Actuator Specifications table, which can be found below.
- (2) Both the horizontal and vertical payloads assume operation at an acceleration of 0.3G.
- (3) When the acceleration is increased, the payload will be reduced. Please refer to "Table of Payload by Acceleration" on P.139 for more details.
- (4) Estimated allowable duty varies depending on operating conditions (payload, acceleration/deceleration, etc.). Please refer to P. 149 for more information.

## Actuator Specifications

### Lead and Payload

Model Number	Motor wattage (W)	Lead (mm)		Max. payload		Rated thrust (N)	Stroke (mm)
		Horizontal (kg)	Vertical (kg)	Horizontal (kg)	Vertical (kg)		
RCS4-WSA12C-WA-100-30- <input type="checkbox"/> -T2- <input type="checkbox"/> - <input type="checkbox"/>	100	30	5	—	57	50~800 (50mm increments)	
RCS4-WSA12C-WA-100-20- <input type="checkbox"/> -T2- <input type="checkbox"/> - <input type="checkbox"/>		20	15	3	85		
RCS4-WSA12C-WA-100-12- <input type="checkbox"/> -T2- <input type="checkbox"/> - <input type="checkbox"/>		12	25	8	142		
RCS4-WSA12C-WA-100-6- <input type="checkbox"/> -T2- <input type="checkbox"/> - <input type="checkbox"/>		6	45	15	283		
RCS4-WSA12C-WA-100-3- <input type="checkbox"/> -T2- <input type="checkbox"/> - <input type="checkbox"/>		3	55	15	566		

Legend:  Stroke  Cable Length  Option

### Stroke and Max Speed

(Unit: mm/s)

Stroke Lead	Stroke (mm)						
	50~500 (50mm increments)	550 (mm)	600 (mm)	650 (mm)	700 (mm)	750 (mm)	800 (mm)
30	1600	1450	1260	1100	970	860	770
20	1200	970	840	740	650	580	520
12	720	535	465	405	355	315	285
6	360	265	230	200	175	155	140
3	180	130	115	100	85	75	70

### ① Stroke

① Stroke (mm)	RCS4-WSA12C	① Stroke (mm)	RCS4-WSA12C
50	<input type="checkbox"/>	450	<input type="checkbox"/>
100	<input type="checkbox"/>	500	<input type="checkbox"/>
150	<input type="checkbox"/>	550	<input type="checkbox"/>
200	<input type="checkbox"/>	600	<input type="checkbox"/>
250	<input type="checkbox"/>	650	<input type="checkbox"/>
300	<input type="checkbox"/>	700	<input type="checkbox"/>
350	<input type="checkbox"/>	750	<input type="checkbox"/>
400	<input type="checkbox"/>	800	<input type="checkbox"/>

### ② Cable Length

Type	Cable Code
Standard	P(1m)
	S(3m)
	M(5m)
Specified length (Standard cable)	X06(6m) ~ X10(10m)
	X11(11m) ~ X15(15m)
	X16(16m) ~ X20(20m)
Robot cable	R01(1m) ~ R03(3m)
	R04(4m) ~ R05(5m)
	R06(6m) ~ R10(10m)
	R11(11m) ~ R15(15m)
	R16(16m) ~ R20(20m)

### ③ Options

Name	Option Code	Reference Page
Brake	B	See P.131
Cable exit direction (Top)	CJT	See P.131
Cable exit direction (Right)	CJR	See P.131
Cable exit direction (Left)	CJL	See P.131
Cable exit direction (Bottom)	CJB	See P.131
High-precision specification *	HPR	See P.134
Non-motor end specification	NM	See P.136
Slider roller specification	SR	See P.137

\* When the lead is 30, it cannot be selected.

### Actuator Specifications

Item	Description
Drive system	Ball screw φ10mm, rolled C10
Positioning repeatability (*1)	±0.01mm (±0.005mm)
Lost motion	0.1 mm or less
Base	Material: Aluminum with white alumite treatment
Allowable static moment	Ma direction 311N·m, Mb direction 311N·m, Mc direction 827N·m
Allowable dynamic moment (*2)	Ma direction 87.5N·m, Mb direction 87.5N·m, Mc direction 233N·m
Ambient operating temp. & humidity	0~40°C, 85% RH or less (Non-condensing)

\* Reference for overhang load length: Ma direction: 450mm or less, Mb, Mc direction: 450mm or less

(\*1) Values in [ ] are for high precision (for lead 3/6/12/20) specification.

(\*2) Assumes a standard rated life of 5,000km. The running life will vary depending on operation and installation conditions. Please contact IAI America for details of the running life.

See page 146 for moment load directions.

If the moment loads in Ma/Mb/Mc are within the allowable ranges, there is no overhang length limit.



\*1 When the slider is returning to its home position, please be careful of interference from surrounding objects, as it will travel until it reaches the M.E.  
M.E: Mechanical end S.E: Stroke end

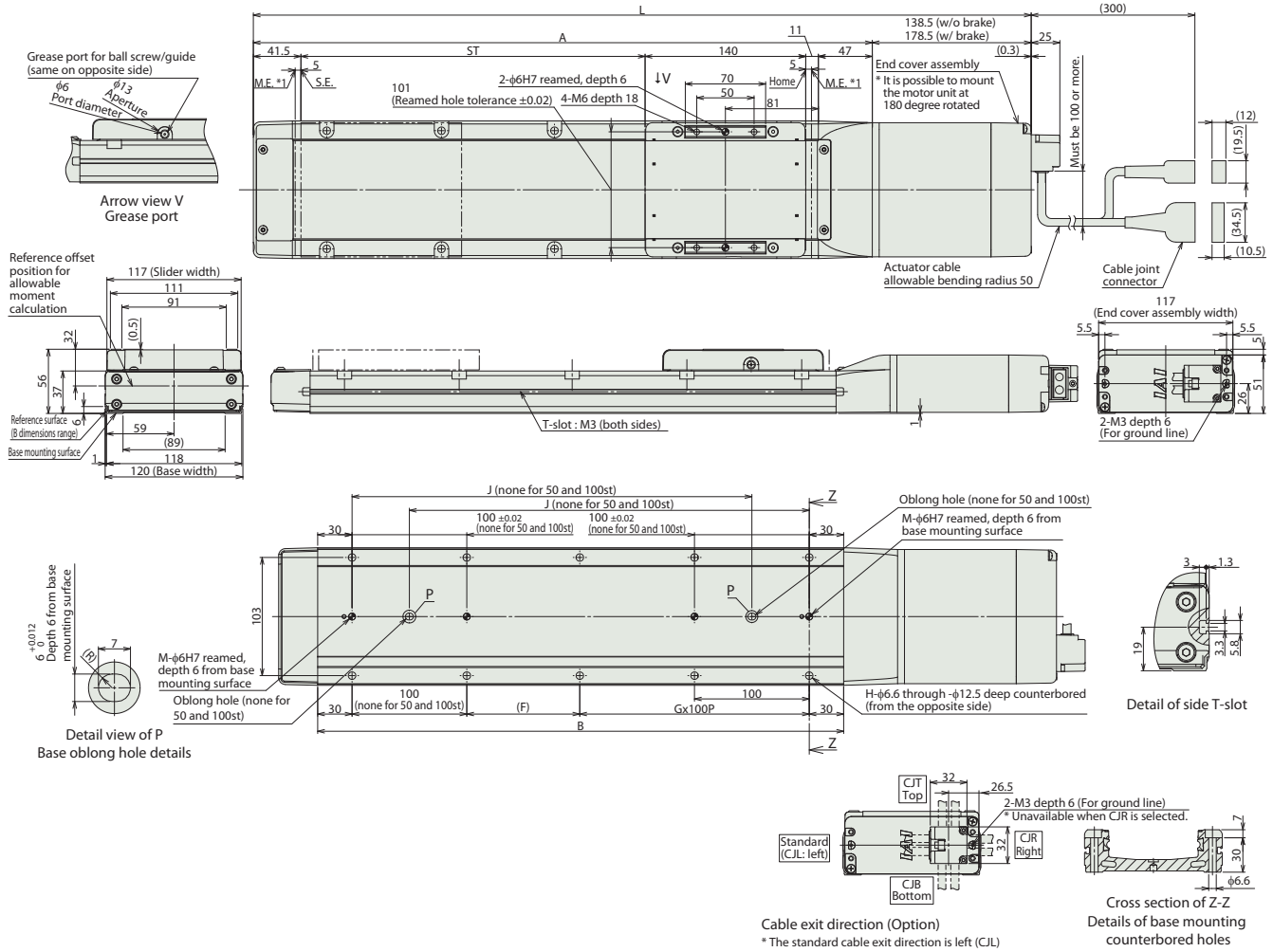

Dimensions and Mass by Stroke

L	Stroke	50	100	150	200	250	300	350	400	450	500	550	600	650	700	750	800
		W/o brake	428	478	528	578	628	678	728	778	828	878	928	978	1028	1078	1128
	W/ brake	468	518	568	618	668	718	768	818	868	918	968	1018	1068	1118	1168	1218
	A	289.5	339.5	389.5	439.5	489.5	539.5	589.5	639.5	689.5	739.5	789.5	839.5	889.5	939.5	989.5	1039.5
	B	208.5	258.5	308.5	358.5	408.5	458.5	508.5	558.5	608.5	658.5	708.5	758.5	808.5	858.5	908.5	958.5
	F	148.5	198.5	248.5	298.5	348.5	398.5	448.5	498.5	548.5	598.5	648.5	698.5	748.5	798.5	848.5	
	G	0	0	1	1	2	2	3	3	4	4	5	5	6	6	7	7
	H	4	4	8	8	10	10	12	12	14	14	16	16	18	18	20	20
	J	-	-	198.5	248.5	298.5	348.5	398.5	448.5	498.5	548.5	598.5	648.5	698.5	748.5	798.5	848.5
	M	1	1	2	2	2	2	2	2	2	2	2	2	2	2	2	2
Mass (kg)	W/o brake	3.8	4.2	4.5	4.8	5.2	5.5	5.8	6.2	6.5	6.9	7.2	7.5	7.9	8.2	8.5	8.9
	W/ brake	4.2	4.6	4.9	5.2	5.6	5.9	6.2	6.6	6.9	7.3	7.6	7.9	8.3	8.6	8.9	9.3

Applicable Controllers

The RCS4 series actuators can be operated by the controllers indicated below. Please select the type depending on your intended use.

Name	External view	Max. number of connectable axes	Input power	Control method				Maximum number of positioning points	Reference page	
				Positioner	Pulse train	Program	Network * Option			
SCON-CB/CGB		1	Single phase 100V/200VAC	●	●	-	DeviceNet CC-Link CC-Link IE CompoNet MECHATROLINK EtherCAT EtherNet/IP CC-Link IE FS	512 (768 for network spec.)	Please contact IAI for more information.	
SCON-LC/LCG		1		-	-	●		512 (768 for network spec.)		
SCON-CAL/CGAL		1		●	-	-		512 (768 for network spec.)		
MSCON-C		6		This model is network-compatible only.				256		
SSEL-CS		2		●	-	●		20000		
XSEL-P/Q/RA/SA		8		Single phase 200VAC Three-phase 200VAC	-	-		●		55000 (Depending on the type)

Note: The type of compatible networks will vary depending on the controller. Please refer to the reference page for more information.

Foreword  
Slider Type  
Wide Slider Type  
Rod Type  
Radial Cylinder  
Wide Radial Cylinder  
Table Type  
Cleanroom Slider  
Cleanroom Wide Slider  
Options  
Reference Data  
Controller

# RCS4-WSA14C



## Model Specification Items

**RCS4** — **WSA14C** — **WA** — **200** —  —  — **T2** —  —

Series — Type — Encoder Type — Motor Type — Lead — Stroke — Applicable Controllers — Cable Length — Options

WA: Battery-less Absolute

200: Servo motor 200W

36:36mm  
24:24mm  
16:16mm  
8: 8mm  
4: 4mm

50:50mm  
800:800mm  
(50mm increments)

T2:SCON  
MSCON  
SSEL  
XSEL-P/Q  
XSEL-RA/SA

N : None  
P : 1m  
S : 3m  
M : 5m  
X□□ : Specified Length  
R□□ : Robot Cable

Refer to Options table below.  
\* Be sure to select an option for the cable exit direction.



\* Depending on the model, there may be some limitations to using the vertical, side, and ceiling mount positions. Please refer to the Selection Notes on P.138 for more information.

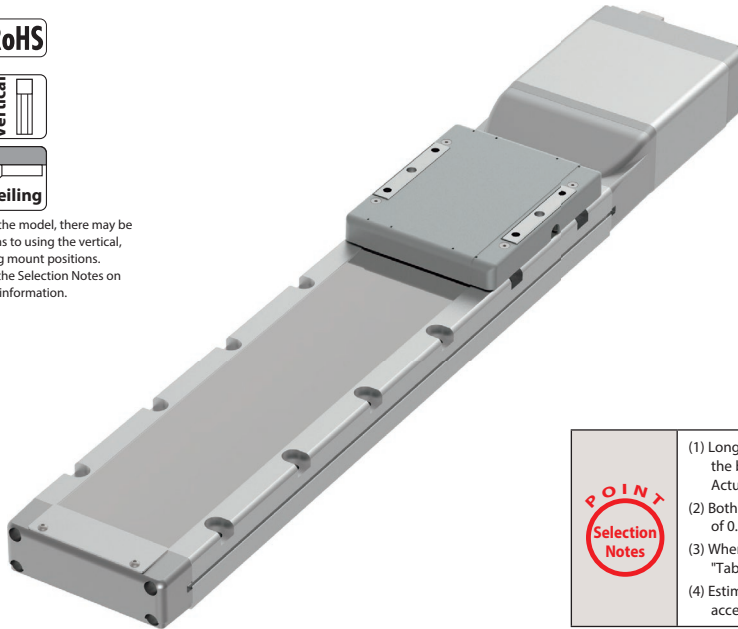

- (1) Longer strokes may cause the maximum speed to decrease due to resonance of the ball screw. Be sure to check the maximum speed of the desired stroke in the Actuator Specifications table, which can be found below.
- (2) Both the horizontal and vertical payloads assume operation at an acceleration of 0.3G.
- (3) When the acceleration is increased, the payload will be reduced. Please refer to "Table of Payload by Acceleration" on P.139 for more details.
- (4) Estimated allowable duty varies depending on operating conditions (payload, acceleration/deceleration, etc.). Please refer to P. 149 for more information.

## Actuator Specifications

### Lead and Payload

Model Number	Motor wattage (W)	Lead (mm)		Max. payload		Rated thrust (N)	Stroke (mm)
		Horizontal (kg)	Vertical (kg)	Horizontal (kg)	Vertical (kg)		
RCS4-WSA14C-WA-200-36-①-T2-②-③	200	36	7	—	95	50~800 (50mm increments)	
RCS4-WSA14C-WA-200-24-①-T2-②-③		24	20	2.5	142		
RCS4-WSA14C-WA-200-16-①-T2-②-③		16	45	8	214		
RCS4-WSA14C-WA-200-8-①-T2-②-③		8	65	10	427		
RCS4-WSA14C-WA-200-4-①-T2-②-③		4	80	25	855		

### Stroke and Max Speed

(Unit: mm/s)

Stroke / Lead	50~550	600	650	700	750	800
	(50mm increments)	(mm)	(mm)	(mm)	(mm)	(mm)
36	1800	1590	1400	1240	1110	990
24	1440	1060	930	830	740	665
16	960	690	610	550	490	440
8	480	350	305	270	240	215
4	240	170	150	135	120	105

Legend: ① Stroke ② Cable Length ③ Option

### ① Stroke

① Stroke (mm)	RCS4-WSA14C	① Stroke (mm)	RCS4-WSA14C
50	○	450	○
100	○	500	○
150	○	550	○
200	○	600	○
250	○	650	○
300	○	700	○
350	○	750	○
400	○	800	○

### ② Cable Length

Type	Cable Code
Standard	P(1m)
	S(3m)
	M(5m)
Specified length (Standard cable)	X06(6m) ~ X10(10m)
	X11(11m) ~ X15(15m)
	X16(16m) ~ X20(20m)
Robot cable	R01(1m) ~ R03(3m)
	R04(4m) ~ R05(5m)
	R06(6m) ~ R10(10m)
	R11(11m) ~ R15(15m)
	R16(16m) ~ R20(20m)
	R21(21m) ~ R25(25m)

### ③ Options

Name	Option Code	Reference Page
Brake	<b>B</b>	See P.131
Cable exit direction (Top)	<b>CJT</b>	See P.131
Cable exit direction (Right)	<b>CJR</b>	See P.131
Cable exit direction (Left)	<b>CJL</b>	See P.131
Cable exit direction (Bottom)	<b>CJB</b>	See P.131
High-precision specification *	<b>HPR</b>	See P.134
Non-motor end specification	<b>NM</b>	See P.136
Slider roller specification	<b>SR</b>	See P.137

\* When the lead is 24/36, it cannot be selected.

### Actuator Specifications

Item	Description
Drive system	Ball screw φ12mm, rolled C10
Positioning repeatability (*1)	±0.01mm (±0.005mm)
Lost motion	0.1 mm or less
Base	Material: Aluminum with white alumite treatment
Allowable static moment	Ma direction 462N·m, Mb direction 462N·m, Mc direction 1170N·m
Allowable dynamic moment (*2)	Ma direction 122N·m, Mb direction 122N·m, Mc direction 308N·m
Ambient operating temp. & humidity	0~40°C, 85% RH or less (Non-condensing)

\* Reference for overhang load length: Ma direction: 550mm or less, Mb, Mc direction: 550mm or less

(\*1) Values in [ ] are for high precision (for lead 4/8/16) specification.

(\*2) Assumes a standard rated life of 5,000km. The running life will vary depending on operation and installation conditions. Please contact IAI America for details of the running life.

See page 146 for moment load directions.

If the moment loads in Ma/Mb/Mc are within the allowable ranges, there is no overhang length limit.



CAD drawings can be downloaded from our website.  
www.intelligentactuator.com



\*1 When the slider is returning to its home position, please be careful of interference from surrounding objects, as it will travel until it reaches the M.E.

M.E: Mechanical end S.E: Stroke end

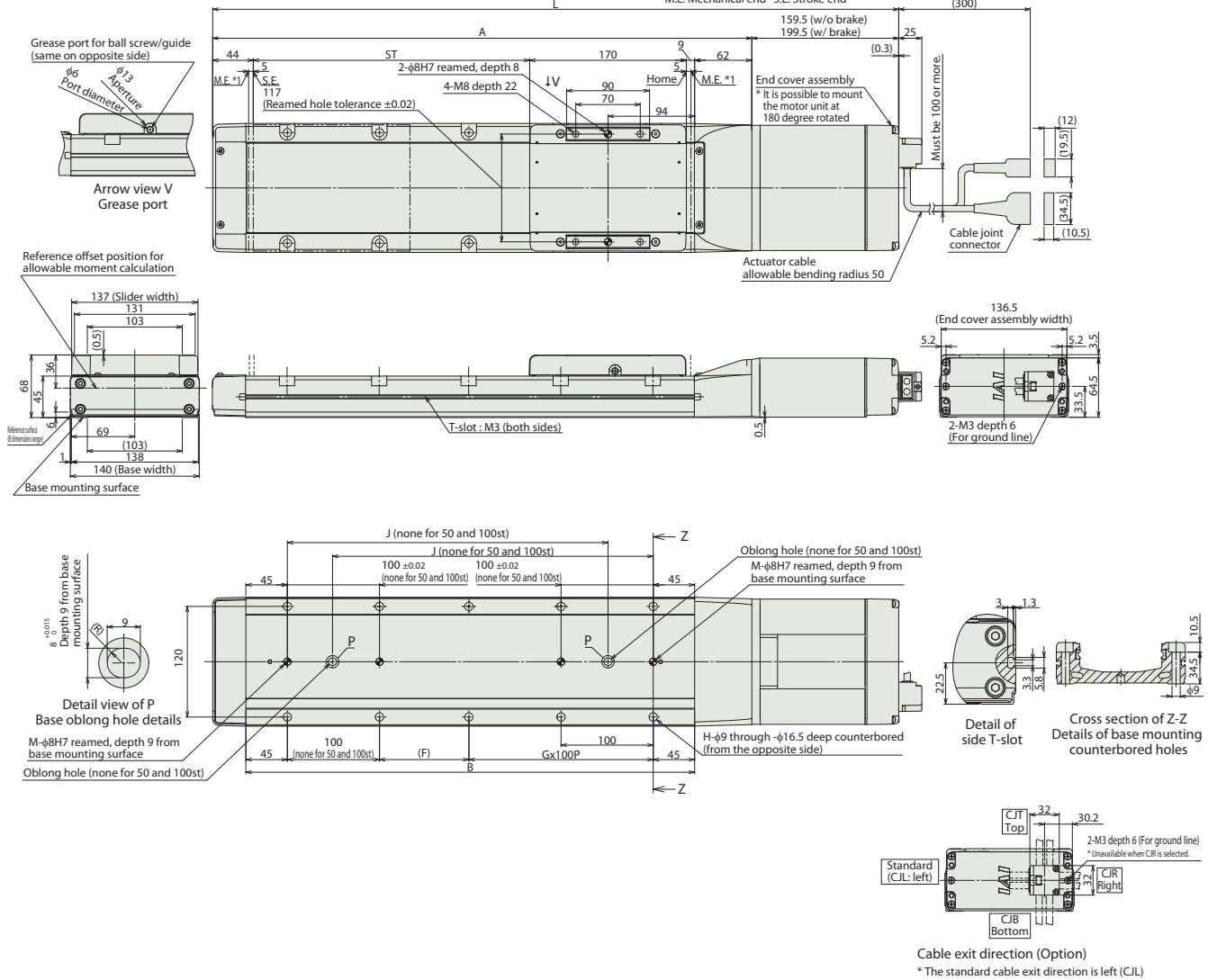

**Dimensions and Mass by Stroke**

L	Stroke	50	100	150	200	250	300	350	400	450	500	550	600	650	700	750	800
	W/o brake	494.5	544.5	594.5	644.5	694.5	744.5	794.5	844.5	894.5	944.5	994.5	1044.5	1094.5	1144.5	1194.5	1244.5
W/ brake	534.5	584.5	634.5	684.5	734.5	784.5	834.5	884.5	934.5	984.5	1034.5	1084.5	1134.5	1184.5	1234.5	1284.5	1284.5
A	335	385	435	485	535	585	635	685	735	785	835	885	935	985	1035	1085	1085
B	237	287	337	387	437	487	537	587	637	687	737	787	837	887	937	987	987
F	147	197	247	297	347	397	447	497	547	597	647	697	747	797	847	897	897
G	0	0	1	1	2	2	3	3	4	4	5	5	6	6	7	7	7
H	4	4	8	8	10	10	12	12	14	14	16	16	18	18	20	20	20
J	-	-	198	248	298	348	398	448	498	548	598	648	698	748	798	848	848
M	1	1	2	2	2	2	2	2	2	2	2	2	2	2	2	2	2
Mass (kg)	W/o brake	6.5	6.9	7.4	7.9	8.4	8.9	9.4	9.9	10.3	10.8	11.3	11.8	12.3	12.8	13.3	13.8
	W/ brake	7.1	7.5	8.0	8.5	9.0	9.5	10.0	10.5	10.9	11.4	11.9	12.4	12.9	13.4	13.9	14.4

**Applicable Controllers**

The RCS4 series actuators can be operated by the controllers indicated below. Please select the type depending on your intended use.

Name	External view	Max. number of connectable axes	Input power	Control method				Maximum number of positioning points	Reference page	
				Positioner	Pulse train	Program	Network * Option			
SCON-CB/CGB		1	Single phase 100V/200VAC	●	●	-	<b>DeviceNet</b> <b>CC-Link</b> <b>PROFINET</b> <b>CompoNet</b> <b>MECHATROLINK</b> <b>EtherCAT</b> <b>EtherNet/IP</b>	512 (768 for network spec.)	Please contact IAI for more information.	
SCON-LC/LCG		1		-	-	●		512 (768 for network spec.)		
SCON-CAL/CGAL		1		●	-	-		512 (768 for network spec.)		
MSCON-C		6		This model is network-compatible only.				256		
SSEL-CS		2		●	-	●		20000		
XSEL-P/Q/RA/SA		8	Single phase 200VAC Three-phase 200VAC	-	-	●	55000 (Depending on the type)			

Note: The type of compatible networks will vary depending on the controller. Please refer to the reference page for more information.

Foreword  
Slider Type  
Wide Slider Type  
Rod Type  
Radial Cylinder  
Wide Radial Cylinder  
Table Type  
Cleanroom Slider  
Cleanroom Wide Slider  
Options  
Reference Data  
Controller

# RCS4-WSA16C



Model Specification Items	<b>RCS4</b> — Series	<b>WSA16C</b> — Type	<b>WA</b> — Encoder Type	<b>400</b> — Motor Type	Lead	Stroke	<b>T2</b> — Applicable Controllers	Cable Length	Options
			WA: Battery-less Absolute	400: Servo motor 400W	30:30mm 20:20mm 10:10mm 5: 5mm	50:50mm 1100:1100mm (50mm increments)	T2:SCON SSEL XSEL-P/Q XSEL-RA/SA	N : None P : 1m S : 3m M : 5m X□□ : Specified Length R□□ : Robot Cable	Refer to Options table below. * Be sure to select an option for the cable exit direction.

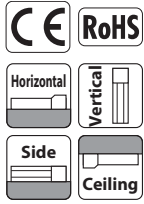

\* Depending on the model, there may be some limitations to using the vertical, side, and ceiling mount positions. Please refer to the Selection Notes on P.138 for more information.

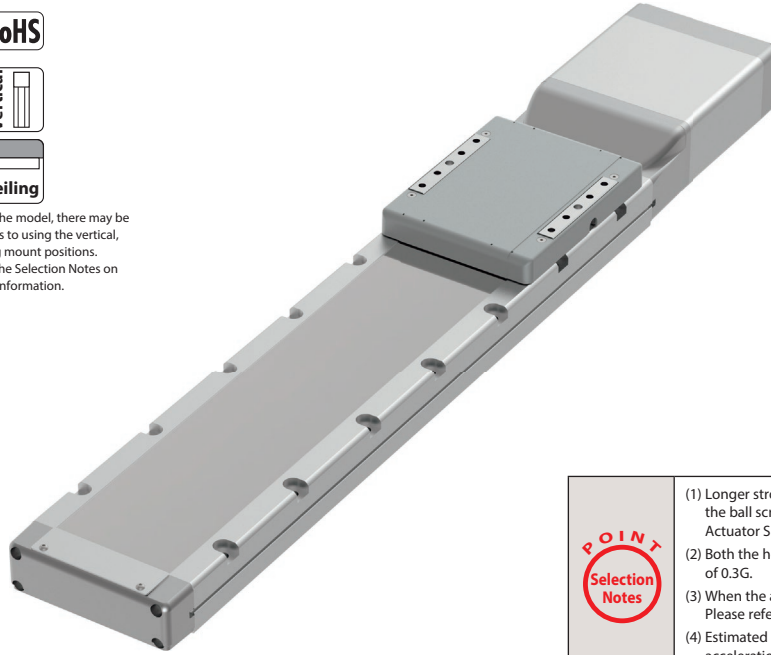

- POINT Selection Notes**
- (1) Longer strokes may cause the maximum speed to decrease due to resonance of the ball screw. Be sure to check the maximum speed of the desired stroke in the Actuator Specifications table, which can be found below.
  - (2) Both the horizontal and vertical payloads assume operation at an acceleration of 0.3G.
  - (3) When the acceleration is increased, the payload will be reduced. Please refer to "Table of Payload by Acceleration" on P.139 for more details.
  - (4) Estimated allowable duty varies depending on operating conditions (payload, acceleration/deceleration, etc.). Please refer to P. 149 for more information.

## Actuator Specifications

### Lead and Payload

Model Number	Motor wattage (W)	Lead (mm)	Max. payload		Rated thrust (N)	Stroke (mm)
			Horizontal (kg)	Vertical (kg)		
RCS4-WSA16C-WA-400-30-①-T2-②-③	400	30	30	12	226	50~1100 (50mm increments)
RCS4-WSA16C-WA-400-20-①-T2-②-③		20	60	20	339	
RCS4-WSA16C-WA-400-10-①-T2-②-③		10	80	35	678	
RCS4-WSA16C-WA-400-5-①-T2-②-③		5	100	50	1357	

Legend: ① Stroke ② Cable Length ③ Option

### Stroke and Max Speed

(Unit: mm/s)

Stroke	Lead											
	50~550 (50mm increments)	600	650	700	750	800	850	900	950	1000	1050	1100
30	1800	1680	1480	1320	1180	1060	960	870	790	730	670	620
20	1200	1120	990	880	780	715	645	590	535	490	450	415
10	600	560	490	440	395	355	320	290	265	240	225	205
5	300	280	240	220	195	175	160	145	130	120	110	100

### ① Stroke

① Stroke (mm)	RCS4-WSA16C	① Stroke (mm)	RCS4-WSA16C
50	○	600	○
100	○	650	○
150	○	700	○
200	○	750	○
250	○	800	○
300	○	850	○
350	○	900	○
400	○	950	○
450	○	1000	○
500	○	1050	○
550	○	1100	○

### ② Cable Length

Type	Cable Code
Standard	P(1m)
	S(3m)
	M(5m)
Specified length (Standard cable)	X06(6m) ~ X10(10m)
	X11(11m) ~ X15(15m)
	X16(16m) ~ X20(20m)
Robot cable	R01(1m) ~ R03(3m)
	R04(4m) ~ R05(5m)
	R06(6m) ~ R10(10m)
	R11(11m) ~ R15(15m)
	R16(16m) ~ R20(20m)

### ③ Options

Name	Option Code	Reference Page
Brake	B	See P.131
Cable exit direction (Top)	CJT	See P.131
Cable exit direction (Right)	CJR	See P.131
Cable exit direction (Left)	CJL	See P.131
Cable exit direction (Bottom)	CJB	See P.131
High-precision specification *	HPR	See P.134
Non-motor end specification	NM	See P.136
Slider roller specification	SR	See P.137

\* When the lead is 30, it cannot be selected.

### Actuator Specifications

Item	Description
Drive system	Ball screw φ16mm, rolled C10
Positioning repeatability (*1)	±0.01mm [±0.005mm]
Lost motion	0.1mm or less
Base	Material: Aluminum with white alumite treatment
Allowable static moment	Ma direction 642N·m, Mb direction 642N·m, Mc direction 1610N·m
Allowable dynamic moment (*2)	Ma direction 161N·m, Mb direction 161N·m, Mc direction 404N·m
Ambient operating temp. & humidity	0~40°C, 85% RH or less (Non-condensing)

\* Reference for overhang load length: Ma direction: 650mm or less, Mb, Mc direction: 650mm or less

(\*1) Values in [ ] are for high precision (for lead 5/10/20) specification.

(\*2) Assumes a standard rated life of 5,000km. The running life will vary depending on operation and installation conditions. Please contact IAI America for details of the running life.

See page 146 for moment load directions.

If the moment loads in Ma/Mb/Mc are within the allowable ranges, there is no overhang length limit.



\*1 When the slider is returning to its home position, please be careful of interference from surrounding objects, as it will travel until it reaches the M.E.  
M.E: Mechanical end S.E: Stroke end

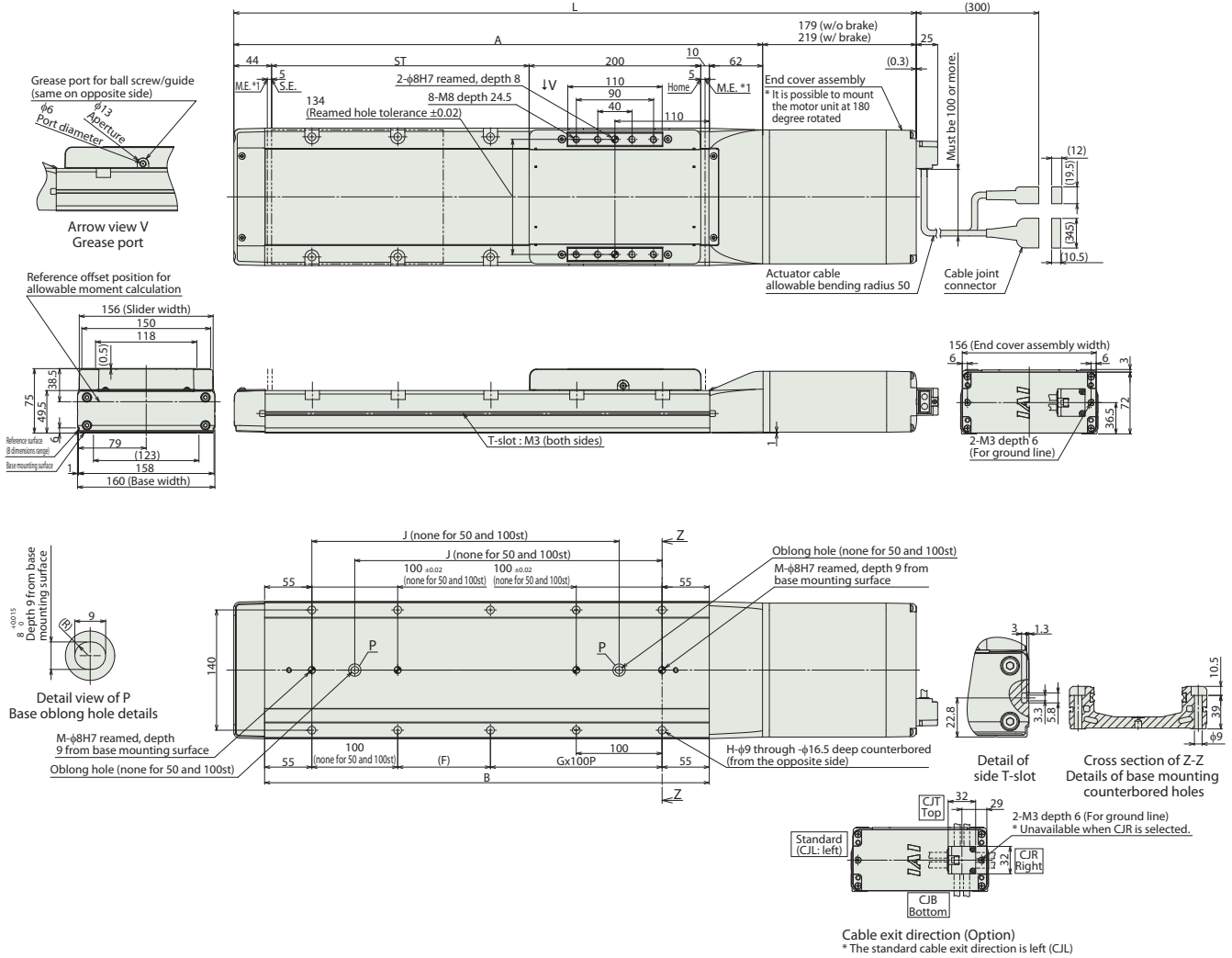

**Dimensions and Mass by Stroke**

Stroke	Dimensions																						
	50	100	150	200	250	300	350	400	450	500	550	600	650	700	750	800	850	900	950	1000	1050	1100	
L	W/o brake	545	595	645	695	745	795	845	895	945	995	1045	1095	1145	1195	1245	1295	1345	1395	1445	1495	1545	1595
	W/ brake	585	635	685	735	785	835	885	935	985	1035	1085	1135	1185	1235	1285	1335	1385	1435	1485	1535	1585	1635
A	366	416	466	516	566	616	666	716	766	816	866	916	966	1016	1066	1116	1166	1216	1266	1316	1366	1416	
B	268	318	368	418	468	518	568	618	668	718	768	818	868	918	968	1018	1068	1118	1168	1218	1268	1318	
F	158	208	258	308	358	408	458	508	558	608	658	708	758	808	858	908	958	1008	1058	1108	1158	1208	
G	0	0	1	1	2	2	3	3	4	4	5	5	6	6	7	7	8	8	9	9	10	10	
H	4	4	8	8	10	10	12	12	14	14	16	16	18	18	20	20	22	22	24	24	26	26	
J	-	-	208	258	308	358	408	458	508	558	608	658	708	758	808	858	908	958	1008	1058	1108	1158	
M	1	1	2	2	2	2	2	2	2	2	2	2	2	2	2	2	2	2	2	2	2	2	
Mass (kg)	W/o brake	9.1	9.8	10.4	11.0	11.6	12.2	12.8	13.4	14.0	14.7	15.3	15.9	16.5	17.1	17.7	18.3	18.9	19.5	20.2	20.8	21.4	22.0
	W/ brake	9.7	10.4	11.0	11.6	12.2	12.8	13.4	14.0	14.6	15.3	15.9	16.5	17.1	17.7	18.3	18.9	19.5	20.2	20.8	21.4	22.0	22.6

**Applicable Controllers**

The RCS4 series actuators can be operated by the controllers indicated below. Please select the type depending on your intended use.

Name	External view	Max. number of connectable axes	Input power	Control method				Maximum number of positioning points	Reference page
				Positioner	Pulse train	Program	Network * Option		
SCON-CB/CGB		1	Single phase 200VAC	●	●	-	<b>DeviceNet</b> <b>CC-Link</b> <b>PROFINET</b> <b>CompoNet</b> <b>MECHATROLINK</b> <b>EtherCAT</b> <b>EtherNet/IP</b> Note: The type of compatible networks will vary depending on the controller. Please refer to the reference page for more information.	512 (768 for network spec.)	Please contact IAI for more information.
SCON-LC/LCG		1		-	-	●		512 (768 for network spec.)	
SSEL-CS		2	Single phase 100V/200VAC	●	-	●		20000	
XSEL-P/Q/RA/SA		8	Single phase 200VAC Three-phase 200VAC	-	-	●	55000 (Depending on the type)		

Foreword  
Slider Type  
Wide Slider Type  
Rod Type  
Radial Cylinder  
Wide Radial Cylinder  
Table Type  
Cleanroom Slider  
Cleanroom Wide Slider  
Options  
Reference Data  
Controller

# RCS4-WSA10R



Model Specification Items	<b>RCS4</b> — <b>WSA10R</b> — <b>WA</b> — <b>60</b> — <input type="checkbox"/> — <input type="checkbox"/> — <b>T2</b> — <input type="checkbox"/> — <input type="checkbox"/>	* Body width does not include the width of the side-mounted motor.						
Series	Type	Encoder Type	Motor Type	Lead	Stroke	Applicable Controllers	Cable Length	Options
WA: Battery-less Absolute	60: Servo motor 60W	16: 16mm 10: 10mm 5: 5mm 2.5: 2.5mm	50: 50mm 500: 500mm (50mm increments)	T2: SCON MSCON SSEL XSEL-P/Q XSEL-RA/SA	N : None P : 1m S : 3m M : 5m X□ : Specified Length R□ : Robot Cable	Refer to Options table below.		

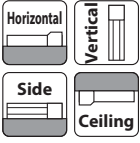

\* Depending on the model, there may be some limitations to using the vertical, side, and ceiling mount positions. Please refer to the Selection Notes on P.138 for more information.

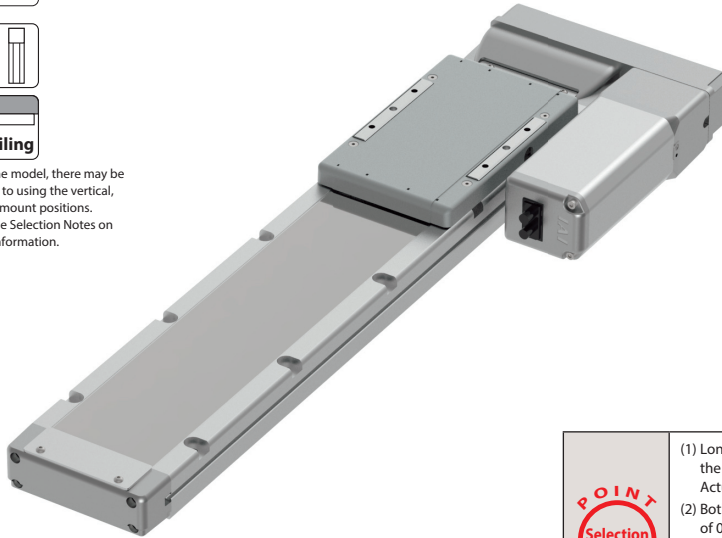

- POINT Selection Notes**
- Longer strokes may cause the maximum speed to decrease due to resonance of the ball screw. Be sure to check the maximum speed of the desired stroke in the Actuator Specifications table, which can be found below.
  - Both the horizontal and vertical payloads assume operation at an acceleration of 0.3G.
  - When the acceleration is increased, the payload will be reduced. Please refer to "Table of Payload by Acceleration" on P.139 for more details.
  - Estimated allowable duty varies depending on operating conditions (payload, acceleration/deceleration, etc.). Please refer to P. 149 for more information.

## Actuator Specifications

### Lead and Payload

Model Number	Motor wattage (W)	Lead (mm)	Max. payload		Rated thrust (N)	Stroke (mm)
			Horizontal (kg)	Vertical (kg)		
RCS4-WSA10R-WA-60-16-①-T2-②-③	60	16	7	—	53	50~500 (50mm increments)
RCS4-WSA10R-WA-60-10-①-T2-②-③		10	16	3	85	
RCS4-WSA10R-WA-60-5-①-T2-②-③		5	27	5	170	
RCS4-WSA10R-WA-60-2.5-①-T2-②-③		2.5	40	10	340	

Legend: ① Stroke ② Cable Length ③ Option

### Stroke and Max Speed

(Unit: mm/s)

Lead	Stroke	50~350 (50mm increments)			
		400 (mm)	450 (mm)	500 (mm)	
16	960	930	775	660	
10	600	590	490	415	
5	300	290	245	205	
2.5	150	145	120	100	

### ① Stroke

① Stroke (mm)	RCS4-WSA10R	① Stroke (mm)	RCS4-WSA10R
50	○	300	○
100	○	350	○
150	○	400	○
200	○	450	○
250	○	500	○

### ② Cable Length

Type	Cable Code
Standard	P(1m)
	S(3m)
	M(5m)
Specified length (Standard cable)	X06(6m) ~ X10(10m)
	X11(11m) ~ X15(15m)
	X16(16m) ~ X20(20m)
Robot cable	R01(1m) ~ R03(3m)
	R04(4m) ~ R05(5m)
	R06(6m) ~ R10(10m)
	R11(11m) ~ R15(15m)
	R16(16m) ~ R20(20m)

### ③ Options

Name	Option Code	Reference Page
Brake	<b>B</b>	See P.131
Cable exit direction (Top)	<b>CJT</b>	See P.131
Cable exit direction (Bottom)	<b>CJB</b>	See P.131
Cable exit direction (Outside)	<b>CJO</b>	See P.131
Motor side-mounted to left (standard)	<b>ML</b>	See P.135
Motor side-mounted to right	<b>MR</b>	See P.135
Non-motor end specification	<b>NM</b>	See P.136
Slider roller specification	<b>SR</b>	See P.137
Slider spacer	<b>SS</b>	See P.137

### Actuator Specifications

Item	Description
Drive system	Ball screw φ8mm, rolled C10
Positioning repeatability	±0.01mm
Lost motion	0.1mm or less
Base	Material: Aluminum with white alumite treatment
Allowable static moment	Ma direction 271N·m, Mb direction 271N·m, Mc direction 553N·m
Allowable dynamic moment (*1)	Ma direction 65.4N·m, Mb direction 65.4N·m, Mc direction 134N·m
Ambient operating temp. & humidity	0~40°C, 85% RH or less (Non-condensing)

\* Reference for overhang load length: Ma direction: 500mm or less, Mb, Mc direction: 500mm or less

(\*1) Assumes a standard rated life of 5,000km. The running life will vary depending on operation and installation conditions. Please contact IAI America for details of the running life.

See page 146 for moment load directions.

If the moment loads in Ma/Mb/Mc are within the allowable ranges, there is no overhang length limit.



\*1 When the slider is returning to its home position, please be careful of interference from surrounding objects, as it will travel until it reaches the M.E.  
M.E: Mechanical end S.E: Stroke end

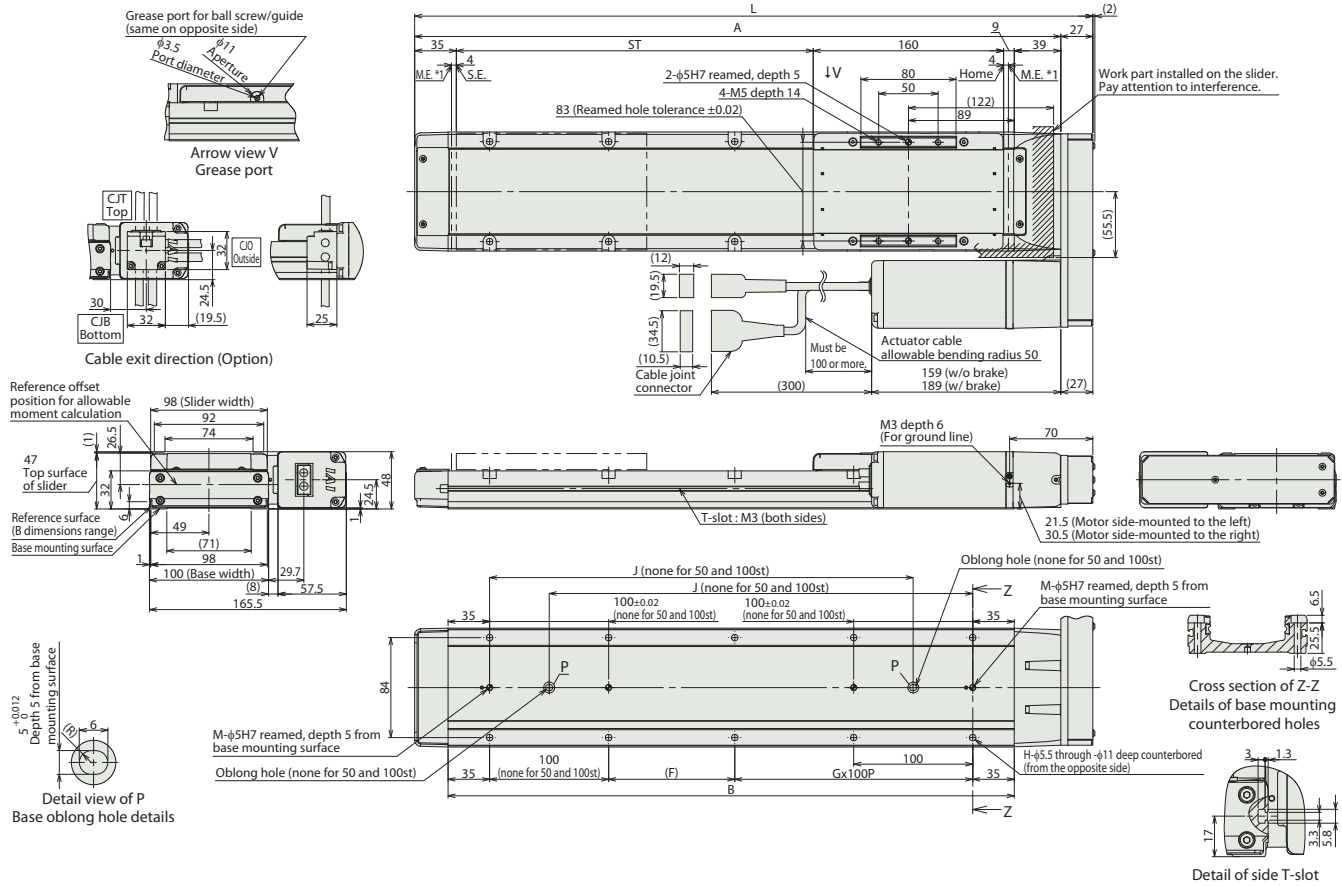

**■ Dimensions and Mass by Stroke**

Stroke	50	100	150	200	250	300	350	400	450	500
L	320	370	420	470	520	570	620	670	720	770
A	293	343	393	443	493	543	593	643	693	743
B	226	276	326	376	426	476	526	576	626	676
F	156	206	56	106	56	106	56	106	56	106
G	0	0	1	1	2	2	3	3	4	4
H	4	4	8	8	10	10	12	12	14	14
J	-	-	206	256	306	356	406	456	506	556
M	1	1	2	2	2	2	2	2	2	2
Mass (kg)	W/o brake	3.2	3.5	3.7	4.0	4.2	4.5	4.7	4.9	5.2
	W/ brake	3.5	3.8	4.0	4.3	4.5	4.8	5.0	5.2	5.5

**Applicable Controllers**

The RCS4 series actuators can be operated by the controllers indicated below. Please select the type depending on your intended use.

Name	External view	Max. number of connectable axes	Input power	Control method				Maximum number of positioning points	Reference page	
				Positioner	Pulse train	Program	Network * Option			
SCON-CB/CGB		1	Single phase 100V/200VAC	●	●	-	DeviceNet CC-Link CC-Link IE CompoNet MECHATROLINK EtherCAT EtherNet/IP EtherCAT	512 (768 for network spec.)	Please contact IAI for more information.	
SCON-LC/LCG		1		-	-	●		512 (768 for network spec.)		
SCON-CAL/CGAL		1		●	-	-		512 (768 for network spec.)		
MSCON-C		6		This model is network-compatible only.				256		
SSEL-CS		2		●	-	●		20000		
XSEL-P/Q/RA/SA		8	Single phase 200VAC Three-phase 200VAC	-	-	●	55000 (Depending on the type)			

Note: The type of compatible networks will vary depending on the controller. Please refer to the reference page for more information.

Foreword  
Slider Type  
Wide Slider Type  
Rod Type  
Radial Cylinder  
Wide Radial Cylinder  
Table Type  
Cleanroom Slider  
Cleanroom Wide Slider  
Options  
Reference Data  
Controller

# RCS4-WSA12R



Model Specification Items	<b>RCS4</b>	<b>— WSA12R</b>	<b>— WA</b>	<b>— 100</b>	<input type="checkbox"/>	<input type="checkbox"/>	<b>T2</b>	<input type="checkbox"/>	<input type="checkbox"/>	* Body width does not include the width of the side-mounted motor.
	Series	Type	Encoder Type	Motor Type	Lead	Stroke	Applicable Controllers	Cable Length	Options	
			WA: Battery-less Absolute	100: Servo motor 100W	30:30mm 20:20mm 12:12mm 6: 6mm 3: 3mm	50:50mm 800:800mm (50mm increments)	T2:SCON MSCON SSEL XSEL-P/Q XSEL-RA/SA	N : None P : 1m S : 3m M : 5m X <input type="checkbox"/> : Specified Length R <input type="checkbox"/> : Robot Cable	Refer to Options table below.	

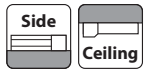

\* Depending on the model, there may be some limitations to using the vertical, side, and ceiling mount positions. Please refer to the Selection Notes on P.138 for more information.

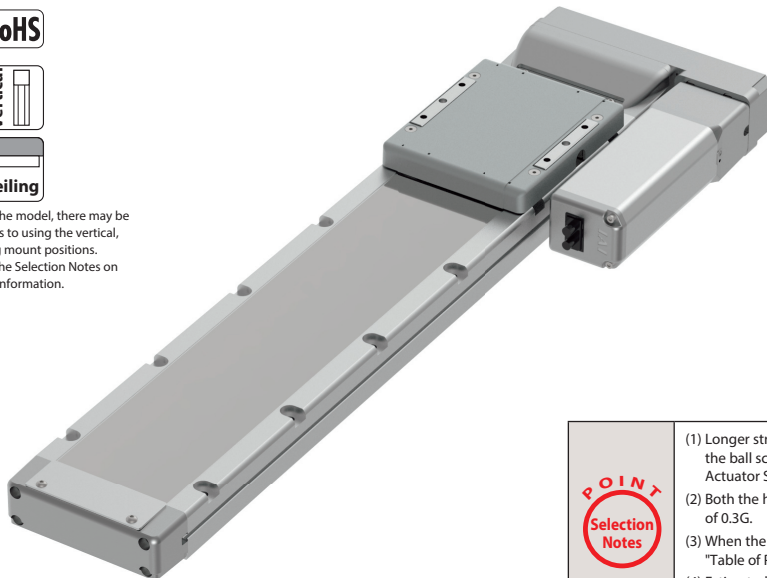

- (1) Longer strokes may cause the maximum speed to decrease due to resonance of the ball screw. Be sure to check the maximum speed of the desired stroke in the Actuator Specifications table, which can be found below.
- (2) Both the horizontal and vertical payloads assume operation at an acceleration of 0.3G.
- (3) When the acceleration is increased, the payload will be reduced. Please refer to "Table of Payload by Acceleration" on P.139 for more details.
- (4) Estimated allowable duty varies depending on operating conditions (payload, acceleration/deceleration, etc.). Please refer to P. 149 for more information.

## Actuator Specifications

### Lead and Payload

Model Number	Motor wattage (W)	Lead (mm)		Max. payload		Rated thrust (N)	Stroke (mm)
		Horizontal (kg)	Vertical (kg)	Horizontal (kg)	Vertical (kg)		
RCS4-WSA12R-WA-100-30-①-T2-②-③	100	30	5	—	57	50~800 (50mm increments)	
RCS4-WSA12R-WA-100-20-①-T2-②-③		20	13	3	85		
RCS4-WSA12R-WA-100-12-①-T2-②-③		12	23	8	142		
RCS4-WSA12R-WA-100-6-①-T2-②-③		6	43	15	283		
RCS4-WSA12R-WA-100-3-①-T2-②-③		3	55	15	566		

### Stroke and Max Speed

(Unit: mm/s)

Stroke / Lead	Stroke (mm)						
	50~500 (50mm increments)	550 (mm)	600 (mm)	650 (mm)	700 (mm)	750 (mm)	800 (mm)
30	1600	1450	1260	1100	970	860	770
20	1200	970	840	740	650	580	520
12	720	535	465	405	355	315	285
6	360	265	230	200	175	155	140
3	180	130	115	100	85	75	70

Legend: ① Stroke ② Cable Length ③ Option

### ① Stroke

① Stroke (mm)	RCS4-WSA12R	① Stroke (mm)	RCS4-WSA12R
50	○	450	○
100	○	500	○
150	○	550	○
200	○	600	○
250	○	650	○
300	○	700	○
350	○	750	○
400	○	800	○

### ② Cable Length

Type	Cable Code
Standard	P(1m)
	S(3m)
	M(5m)
Specified length (Standard cable)	X06(6m) ~ X10(10m)
	X11(11m) ~ X15(15m)
	X16(16m) ~ X20(20m)
Robot cable	R01(1m) ~ R03(3m)
	R04(4m) ~ R05(5m)
	R06(6m) ~ R10(10m)
	R11(11m) ~ R15(15m)
	R16(16m) ~ R20(20m)

### ③ Options

Name	Option Code	Reference Page
Brake	B	See P.131
Cable exit direction (Top)	CJT	See P.131
Cable exit direction (Bottom)	CJB	See P.131
Cable exit direction (Outside)	CJO	See P.131
Motor side-mounted to left (standard)	ML	See P.135
Motor side-mounted to right	MR	See P.135
Non-motor end specification	NM	See P.136
Slider roller specification	SR	See P.137

### Actuator Specifications

Item	Description
Drive system	Ball screw φ10mm, rolled C10
Positioning repeatability	±0.01mm
Lost motion	0.1 mm or less
Base	Material: Aluminum with white alumite treatment
Allowable static moment	Ma direction 311N·m, Mb direction 311N·m, Mc direction 827N·m
Allowable dynamic moment (*1)	Ma direction 87.5N·m, Mb direction 87.5N·m, Mc direction 233N·m
Ambient operating temp. & humidity	0~40°C, 85% RH or less (Non-condensing)

\* Reference for overhang load length: Ma direction: 450mm or less, Mb, Mc direction: 450mm or less

(\*1) Assumes a standard rated life of 5,000km. The running life will vary depending on operation and installation conditions. Please contact IAI America for details of the running life.

See page 146 for moment load directions.

If the moment loads in Ma/Mb/Mc are within the allowable ranges, there is no overhang length limit.

CAD drawings can be downloaded from our website.  
www.intelligentactuator.com



\*1 When the slider is returning to its home position, please be careful of interference from surrounding objects, as it will travel until it reaches the M.E.  
M.E: Mechanical end S.E: Stroke end

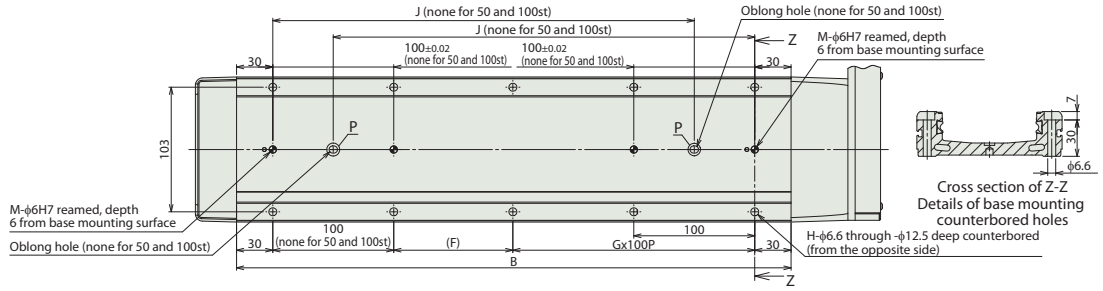
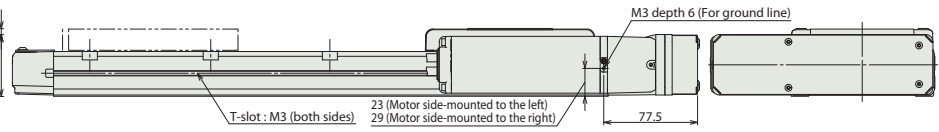
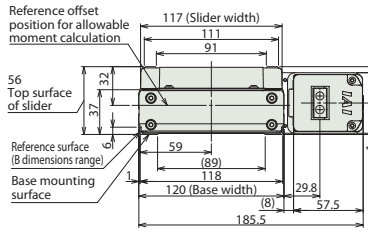
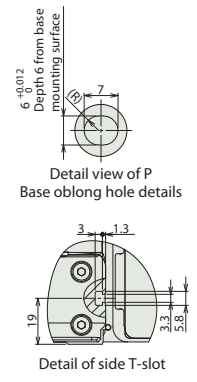
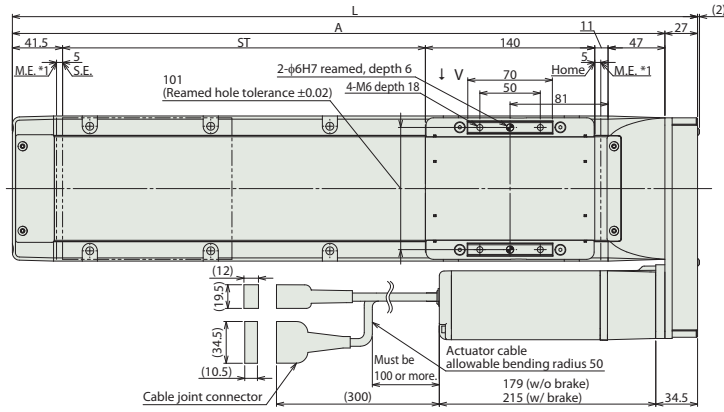
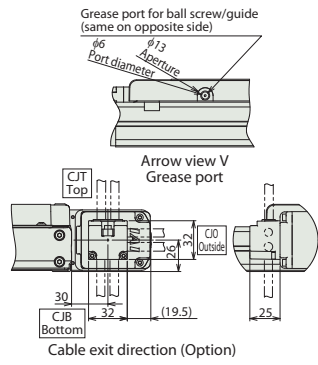

**Dimensions and Mass by Stroke**

Stroke	50	100	150	200	250	300	350	400	450	500	550	600	650	700	750	800
L	316.5	366.5	416.5	466.5	516.5	566.5	616.5	666.5	716.5	766.5	816.5	866.5	916.5	966.5	1016.5	1066.5
A	289.5	339.5	389.5	439.5	489.5	539.5	589.5	639.5	689.5	739.5	789.5	839.5	889.5	939.5	989.5	1039.5
B	208.5	258.5	308.5	358.5	408.5	458.5	508.5	558.5	608.5	658.5	708.5	758.5	808.5	858.5	908.5	958.5
F	148.5	198.5	248.5	298.5	348.5	398.5	448.5	498.5	548.5	598.5	648.5	698.5	748.5	798.5	848.5	898.5
G	0	0	1	1	2	2	3	4	4	5	5	6	6	7	7	7
H	4	4	8	8	10	10	12	12	14	14	16	16	18	18	20	20
J	-	-	198.5	248.5	298.5	348.5	398.5	448.5	498.5	548.5	598.5	648.5	698.5	748.5	798.5	848.5
M	1	1	2	2	2	2	2	2	2	2	2	2	2	2	2	2
Mass (kg)	W/o brake	4.2	4.5	4.9	5.2	5.6	5.9	6.2	6.6	6.9	7.2	7.6	7.9	8.3	8.6	8.9
	W/ brake	4.5	4.8	5.2	5.5	5.9	6.2	6.5	6.9	7.2	7.5	7.9	8.2	8.6	8.9	9.6

**Applicable Controllers**

The RCS4 series actuators can be operated by the controllers indicated below. Please select the type depending on your intended use.

Name	External view	Max. number of connectable axes	Input power	Control method				Maximum number of positioning points	Reference page	
				Positioner	Pulse train	Program	Network * Option			
SCON-CB/CGB		1	Single phase 100V/200VAC	●	●	-	<b>DeviceNet</b> <b>CC-Link</b> <b>CompoNet</b> <b>MECHATROLINK</b> <b>EtherCAT</b> <b>EtherNet/IP</b>	512 (768 for network spec.)	Please contact IAI for more information.	
SCON-LC/LCG		1		-	-	●		512 (768 for network spec.)		
SCON-CAL/CGAL		1		●	-	-		512 (768 for network spec.)		
MSCON-C		6		This model is network-compatible only.				256		
SSEL-CS		2		●	-	●		20000		
XSEL-P/Q/RA/SA		8	Single phase 200VAC Three-phase 200VAC	-	-	●	55000 (Depending on the type)			

Note:  
The type of compatible networks will vary depending on the controller. Please refer to the reference page for more information.

Foreword  
Slider Type  
Wide Slider Type  
Rod Type  
Radial Cylinder  
Wide Radial Cylinder  
Table Type  
Cleanroom Slider  
Cleanroom Wide Slider  
Options  
Reference Data  
Controller

# RCS4-WSA14R



■ Model Specification Items	RCS4	—	WSA14R	—	WA	—	200	—		—		—		—		T2	—		—		* Body width does not include the width of the side-mounted motor.	
	Series		Type		Encoder Type		Motor Type		Lead		Stroke		Applicable Controllers		Cable Length		Options	Refer to Options table below.				
					WA: Battery-less Absolute		200: Servo motor 200W		36:36mm 24:24mm 16:16mm 8: 8mm 4: 4mm		50:50mm 800:800mm (50mm increments)		T2:SCON MSCON SSEL XSEL-P/Q XSEL-RA/SA		N : None P : 1m S : 3m M : 5m		X□□ : Specified Length R□□ : Robot Cable					



\* Depending on the model, there may be some limitations to using the vertical, side, and ceiling mount positions. Please refer to the Selection Notes on P.138 for more information.

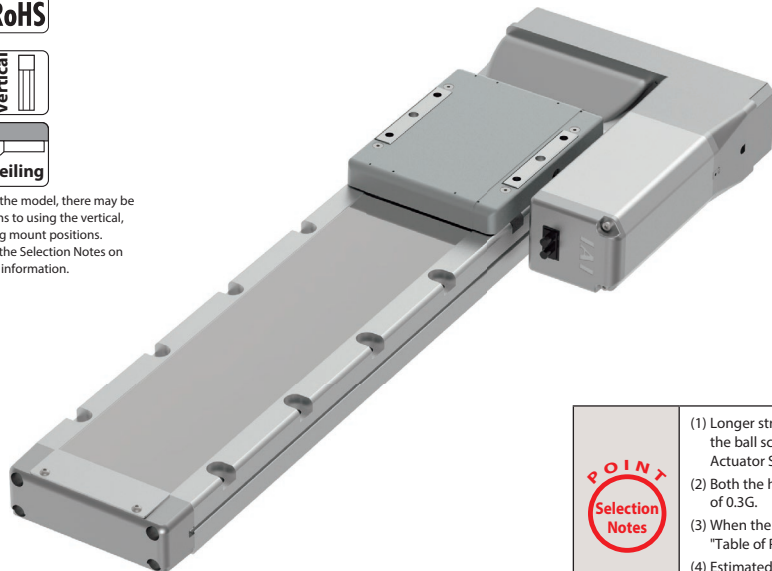

POINT  
Selection  
Notes

- (1) Longer strokes may cause the maximum speed to decrease due to resonance of the ball screw. Be sure to check the maximum speed of the desired stroke in the Actuator Specifications table, which can be found below.
- (2) Both the horizontal and vertical payloads assume operation at an acceleration of 0.3G.
- (3) When the acceleration is increased, the payload will be reduced. Please refer to "Table of Payload by Acceleration" on P.139 for more details.
- (4) Estimated allowable duty varies depending on operating conditions (payload, acceleration/deceleration, etc.). Please refer to P. 149 for more information.

Actuator Specifications													
Lead and Payload						Stroke and Max Speed						(Unit: mm/s)	
Model Number	Motor wattage (W)	Lead (mm)	Max. payload		Rated thrust (N)	Stroke (mm)	Stroke	50~550 (50mm increments)	600 (mm)	650 (mm)	700 (mm)	750 (mm)	800 (mm)
			Horizontal (kg)	Vertical (kg)				Lead					
RCS4-WSA14R-WA-200-36-①-T2-②-③	200	36	7	—	95	50~800 (50mm increments)	36	1710	1590	1400	1240	1110	990
RCS4-WSA14R-WA-200-24-①-T2-②-③		24	20	2.5	142		24	1440	1060	930	830	740	665
RCS4-WSA14R-WA-200-16-①-T2-②-③		16	45	8	214		16	960	690	610	550	490	440
RCS4-WSA14R-WA-200-8-①-T2-②-③		8	65	10	427		8	480	350	305	270	240	215
RCS4-WSA14R-WA-200-4-①-T2-②-③		4	75	25	855		4	240	170	150	135	120	105

Legend: ① Stroke ② Cable Length ③ Option

① Stroke			
① Stroke (mm)	RCS4-WSA14R	① Stroke (mm)	RCS4-WSA14R
50	○	450	○
100	○	500	○
150	○	550	○
200	○	600	○
250	○	650	○
300	○	700	○
350	○	750	○
400	○	800	○

② Cable Length	
Type	Cable Code
Standard	P(1m) S(3m) M(5m)
	Specified length (Standard cable) X06(6m)~X10(10m) X11(11m)~X15(15m) X16(16m)~X20(20m)
	Robot cable R01(1m)~R03(3m) R04(4m)~R05(5m) R06(6m)~R10(10m) R11(11m)~R15(15m) R16(16m)~R20(20m)

③ Options		
Name	Option Code	Reference Page
Brake	<b>B</b>	See P.131
Cable exit direction (Top)	<b>CJT</b>	See P.131
Cable exit direction (Bottom)	<b>CJB</b>	See P.131
Cable exit direction (Outside)	<b>CJO</b>	See P.131
Motor side-mounted to left (standard)	<b>ML</b>	See P.135
Motor side-mounted to right	<b>MR</b>	See P.135
Non-motor end specification	<b>NM</b>	See P.136
Slider roller specification	<b>SR</b>	See P.137
Slider spacer	<b>SS</b>	See P.137

Actuator Specifications	
Item	Description
Drive system	Ball screw φ12mm, rolled C10
Positioning repeatability	±0.01mm
Lost motion	0.1 mm or less
Base	Material: Aluminum with white alumite treatment
Allowable static moment	Ma direction 462N·m, Mb direction 462N·m, Mc direction 1170N·m
Allowable dynamic moment (*1)	Ma direction 122N·m, Mb direction 122N·m, Mc direction 308N·m
Ambient operating temp. & humidity	0~40°C, 85% RH or less (Non-condensing)

\* Reference for overhang load length: Ma direction: 550mm or less, Mb, Mc direction: 550mm or less  
 (\*1) Assumes a standard rated life of 5,000km. The running life will vary depending on operation and installation conditions. Please contact IAI America for details of the running life.  
 See page 146 for moment load directions.  
 If the moment loads in Ma/Mb/Mc are within the allowable ranges, there is no overhang length limit.





\*1 When the slider is returning to its home position, please be careful of interference from surrounding objects, as it will travel until it reaches the M.E.  
M.E: Mechanical end S.E: Stroke end

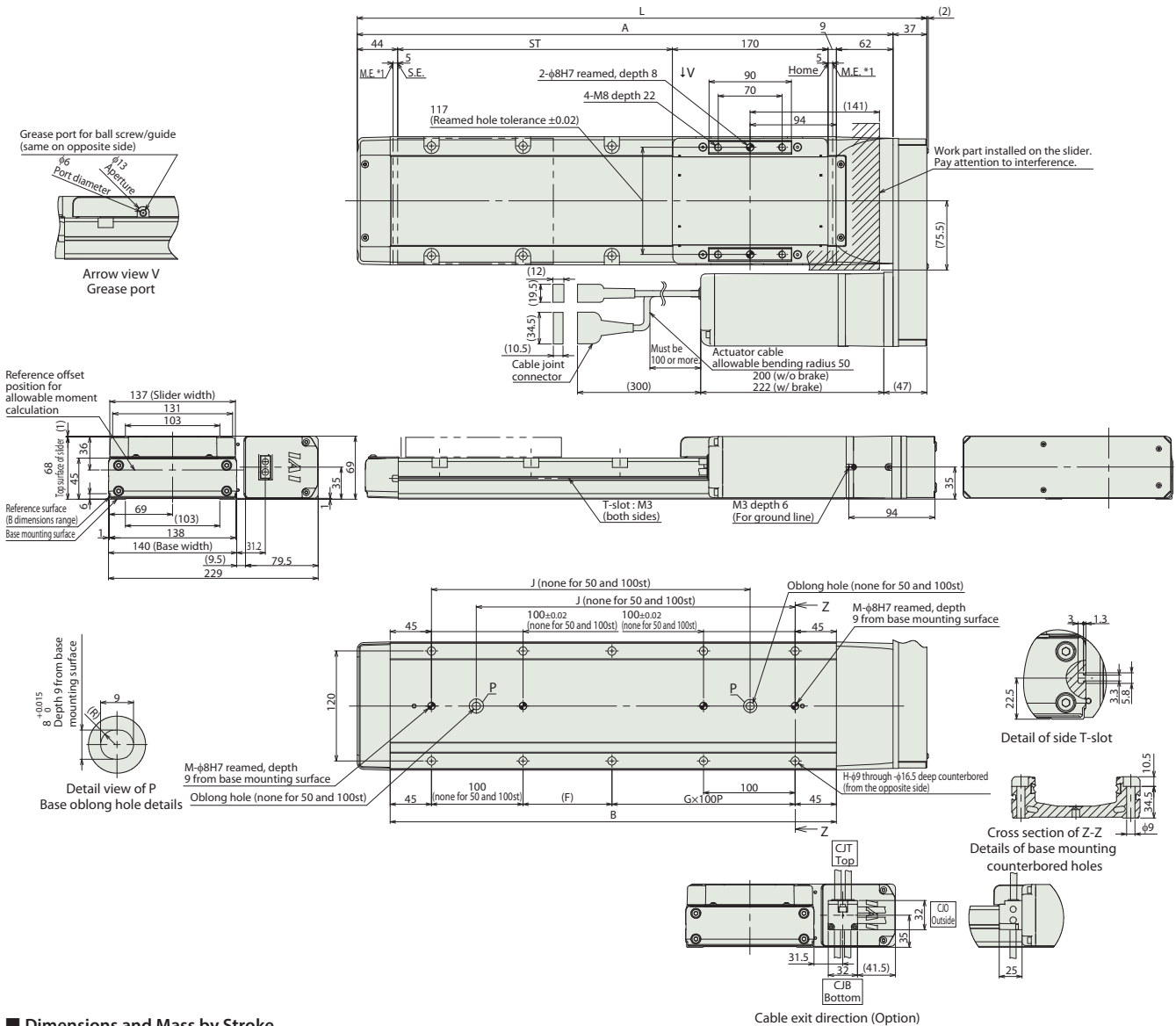

■ Dimensions and Mass by Stroke

Stroke	50	100	150	200	250	300	350	400	450	500	550	600	650	700	750	800	
L	372	422	472	522	572	622	672	722	772	822	872	922	972	1022	1072	1122	
A	335	385	435	485	535	585	635	685	735	785	835	885	935	985	1035	1085	
B	237	287	337	387	437	487	537	587	637	687	737	787	837	887	937	987	
F	147	197	247	297	347	397	447	497	547	597	647	697	747	797	847	897	
G	0	0	1	1	2	2	3	3	4	4	5	5	6	6	7	7	
H	4	4	8	8	10	10	12	12	14	14	16	16	18	18	20	20	
J	-	-	198	248	298	348	398	448	498	548	598	648	698	748	798	848	
M	1	1	2	2	2	2	2	2	2	2	2	2	2	2	2	2	
Mass (kg)	W/o brake	7.4	7.9	8.4	8.9	9.4	9.9	10.3	10.8	11.3	11.8	12.3	12.8	13.3	13.8	14.2	14.7
	W/ brake	8.0	8.5	9.0	9.5	10.0	10.5	10.9	11.4	11.9	12.4	12.9	13.4	13.9	14.4	14.8	15.3

Applicable Controllers

The RCS4 series actuators can be operated by the controllers indicated below. Please select the type depending on your intended use.

Name	External view	Max. number of connectable axes	Input power	Control method				Maximum number of positioning points	Reference page	
				Positioner	Pulse train	Program	Network * Option			
SCON-CB/CGB		1	Single phase 100V/200VAC	●	●	-	DeviceNet CC-Link CompoNet MECHATROLINK EtherCAT EtherNet/IP	512 (768 for network spec.)	Please contact IAI for more information.	
SCON-LC/LCG		1		-	-	●		512 (768 for network spec.)		
SCON-CAL/CGAL		1		●	-	-		512 (768 for network spec.)		
MSCON-C		6		This model is network-compatible only.				256		
SSEL-CS		2		●	-	●		20000		
XSEL-P/Q/RA/SA		8	Single phase 200VAC Three-phase 200VAC	-	-	●	55000 (Depending on the type)			

Note:  
The type of compatible networks will vary depending on the controller. Please refer to the reference page for more information.

Foreword  
Slider Type  
Wide Slider Type  
Rod Type  
Radial Cylinder  
Wide Radial Cylinder  
Table Type  
Cleanroom Slider  
Cleanroom Wide Slider  
Options  
Reference Data  
Controller

# RCS4-WSA16R

±10μm Simple Dust-proof Battery-less Absolute Motor Unit Type Side-mounted Motor Body Width 160mm\* 200v AC Servo Motor

Model Specification Items	<b>RCS4</b> — <b>WSA16R</b> — <b>WA</b> — <b>400</b> — [ ] — [ ] — [ ] — [ ] — [ ]	<b>T2</b> — [ ] — [ ]	* Body width does not include the width of the side-mounted motor.					
Series	Type	Encoder Type	Motor Type	Lead	Stroke	Applicable Controllers	Cable Length	Options
		WA: Battery-less Absolute	400: Servo motor 400W	30:30mm 20:20mm 10:10mm 5: 5mm	50:50mm 1100:1100mm (50mm increments)	T2:SCON SSEL XSEL-P/Q XSEL-RA/SA	N : None P : 1m S : 3m M : 5m	Refer to Options table below.
							X□ : Specified Length	R□ : Robot Cable

CE RoHS  
Horizontal Vertical  
Side Ceiling

\* Depending on the model, there may be some limitations to using the vertical, side, and ceiling mount positions. Please refer to the Selection Notes on P.138 for more information.

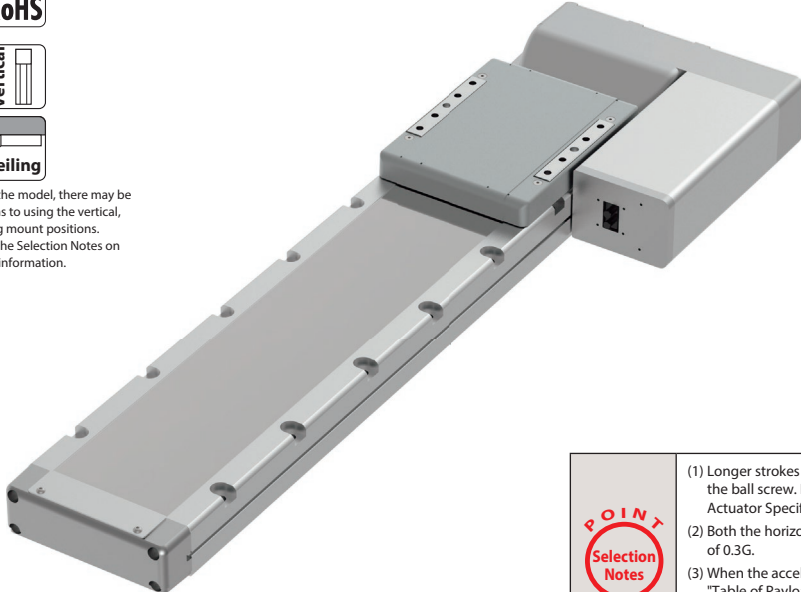

**POINT Selection Notes**

- (1) Longer strokes may cause the maximum speed to decrease due to resonance of the ball screw. Be sure to check the maximum speed of the desired stroke in the Actuator Specifications table, which can be found below.
- (2) Both the horizontal and vertical payloads assume operation at an acceleration of 0.3G.
- (3) When the acceleration is increased, the payload will be reduced. Please refer to "Table of Payload by Acceleration" on P.139 for more details.
- (4) Estimated allowable duty varies depending on operating conditions (payload, acceleration/deceleration, etc.). Please refer to P. 149 for more information.

## Actuator Specifications

### Lead and Payload

Model Number	Motor wattage (W)	Lead (mm)	Max. payload		Rated thrust (N)	Stroke (mm)
			Horizontal (kg)	Vertical (kg)		
RCS4-WSA16R-WA-400-30-①-T2-②-③	400	30	30	12	226	50~1100 (50mm increments)
RCS4-WSA16R-WA-400-20-①-T2-②-③		20	60	18	339	
RCS4-WSA16R-WA-400-10-①-T2-②-③		10	80	35	678	
RCS4-WSA16R-WA-400-5-①-T2-②-③		5	100	50	1357	

Legend: ① Stroke ② Cable Length ③ Option

### Stroke and Max Speed

(Unit: mm/s)

Stroke	50~50	600	650	700	750	800	850	900	950	1000	1050	1100
	(50mm increments)	(mm)	(mm)	(mm)	(mm)	(mm)	(mm)	(mm)	(mm)	(mm)	(mm)	(mm)
30	1800	1680	1480	1320	1180	1060	960	870	790	730	670	620
20	1200	1120	990	880	780	715	645	590	535	490	450	415
10	600	560	490	440	395	355	320	290	265	240	225	205
5	300	280	240	220	195	175	160	145	130	120	110	100

### ① Stroke

① Stroke (mm)	RCS4-WSA16R	① Stroke (mm)	RCS4-WSA16R
50	○	600	○
100	○	650	○
150	○	700	○
200	○	750	○
250	○	800	○
300	○	850	○
350	○	900	○
400	○	950	○
450	○	1000	○
500	○	1050	○
550	○	1100	○

### ② Cable Length

Type	Cable Code
Standard	P(1m)
	S(3m)
	M(5m)
Specified length (Standard cable)	X06(6m) ~ X10(10m)
	X11(11m) ~ X15(15m)
	X16(16m) ~ X20(20m)
Robot cable	R01(1m) ~ R03(3m)
	R04(4m) ~ R05(5m)
	R06(6m) ~ R10(10m)
	R11(11m) ~ R15(15m)
	R16(16m) ~ R20(20m)

### ③ Options

Name	Option Code	Reference Page
Brake	B	See P.131
Cable exit direction (Top)	CJT	See P.131
Cable exit direction (Bottom)	CJB	See P.131
Cable exit direction (Outside)	CJO	See P.131
Motor side-mounted to left (standard)	ML	See P.135
Motor side-mounted to right	MR	See P.135
Non-motor end specification	NM	See P.136
Slider roller specification	SR	See P.137

### Actuator Specifications

Item	Description
Drive system	Ball screw φ16mm, rolled C10
Positioning repeatability	±0.01mm
Lost motion	0.1 mm or less
Base	Material: Aluminum with white alumite treatment
Allowable static moment	Ma direction 642N-m, Mb direction 642N-m, Mc direction 1610N-m
Allowable dynamic moment (*1)	Ma direction 161N-m, Mb direction 161N-m, Mc direction 404N-m
Ambient operating temp. & humidity	0~40°C, 85% RH or less (Non-condensing)

\* Reference for overhang load length: Ma direction: 650mm or less, Mb, Mc direction: 650mm or less

(\*1) Assumes a standard rated life of 5,000km. The running life will vary depending on operation and installation conditions. Please contact IAI America for details of the running life.

See page 146 for moment load directions. If the moment loads in Ma/Mb/Mc are within the allowable ranges, there is no overhang length limit.



\*1 When the slider is returning to its home position, please be careful of interference from surrounding objects, as it will travel until it reaches the M.E.  
M.E: Mechanical end S.E: Stroke end

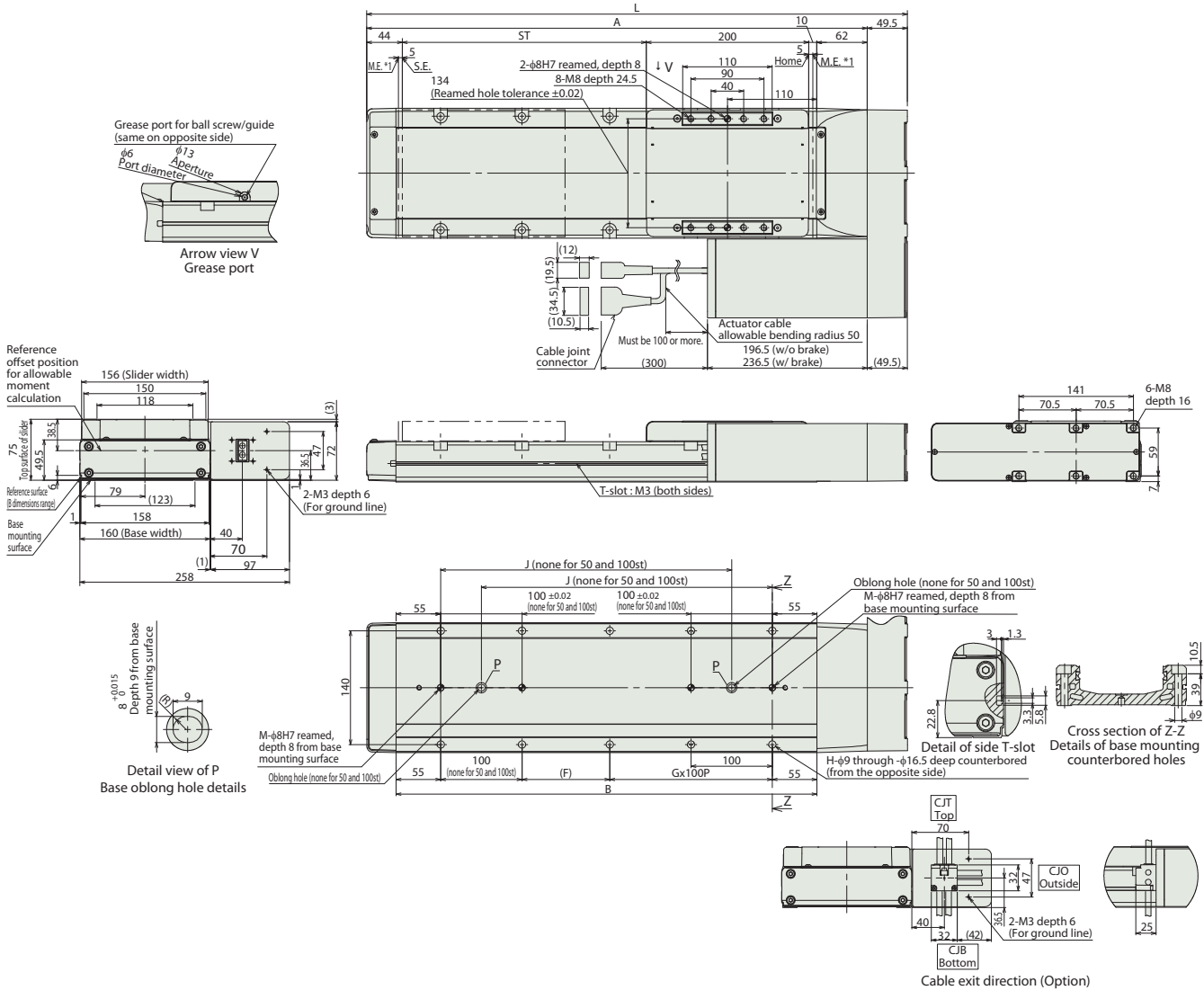

**Dimensions and Mass by Stroke**

Stroke	50	100	150	200	250	300	350	400	450	500	550	600	650	700	750	800	850	900	950	1000	1050	1100	
L	415.5	465.5	515.5	565.5	615.5	665.5	715.5	765.5	815.5	865.5	915.5	965.5	1015.5	1065.5	1115.5	1165.5	1215.5	1265.5	1315.5	1365.5	1415.5	1465.5	
A	366	416	466	516	566	616	666	716	766	816	866	916	966	1016	1066	1116	1166	1216	1266	1316	1366	1416	
B	268	318	368	418	468	518	568	618	668	718	768	818	868	918	968	1018	1068	1118	1168	1218	1268	1318	
F	158	208	258	308	358	408	458	508	558	608	658	708	758	808	858	908	958	1008	1058	1108	1158	1208	
G	0	0	1	1	2	2	3	3	4	4	5	5	6	6	7	7	8	8	9	9	10	10	
H	4	4	8	8	10	10	12	12	14	14	16	16	18	18	20	20	22	22	24	24	26	26	
J	-	-	208	258	308	358	408	458	508	558	608	658	708	758	808	858	908	958	1008	1058	1108	1158	
M	1	1	2	2	2	2	2	2	2	2	2	2	2	2	2	2	2	2	2	2	2	2	
Mass (kg)	W/o brake	10.6	11.2	11.8	12.4	13.0	13.6	14.2	14.9	15.5	16.1	16.7	17.3	17.9	18.5	19.1	19.8	20.4	21.0	21.6	22.2	22.8	23.4
	W/ brake	11.2	11.8	12.4	13.0	13.6	14.2	14.8	15.5	16.1	16.7	17.3	17.9	18.5	19.1	19.7	20.4	21.0	21.6	22.2	22.8	23.4	24.0

**Applicable Controllers**

The RCS4 series actuators can be operated by the controllers indicated below. Please select the type depending on your intended use.

Name	External view	Max. number of connectable axes	Input power	Control method				Maximum number of positioning points	Reference page
				Positioner	Pulse train	Program	Network * Option		
SCON-CB/CGB		1	Single phase 200VAC	●	●	-	<b>DeviceNet</b> <b>CC-Link</b> <b>CompoNet</b> <b>MECHATROLINK</b> <b>EtherCAT</b> <b>EtherNet/IP</b> Note: The type of compatible networks will vary depending on the controller. Please refer to the reference page for more information.	512 (768 for network spec.)	Please contact IAI for more information.
SCON-LC/LCG		1		-	-	●		512 (768 for network spec.)	
SSEL-CS		2	Single phase 100V/200VAC	●	-	●		20000	
XSEL-P/Q/RA/SA		8	Single phase 200VAC Three-phase 200VAC	-	-	●		55000 (Depending on the type)	

Foreword  
Slider Type  
Wide Slider Type  
Rod Type  
Radial Cylinder  
Wide Radial Cylinder  
Table Type  
Cleanroom Slider  
Cleanroom Wide Slider  
Options  
Reference Data  
Controller

# RCS4-RA4C

Battery-less Absolute

Motor Unit Type

Coupled Motor

Body Width  
40 mm

200v AC Servo Motor

Model Specification Items	<b>RCS4</b> — <b>RA4C</b> — <b>WA</b> — <b>60</b> — <input type="checkbox"/> — <input type="checkbox"/> — <b>T2</b> — <input type="checkbox"/> — <input type="checkbox"/>
	Series — Type — Encoder Type — Motor Type — Lead — Stroke — Applicable Controllers — Cable Length — Options
	WA: Battery-less Absolute    60: Servo motor 60W    16: 16mm 10: 10mm 5: 5mm 2.5: 2.5mm    50: 50mm 200: 200mm (50mm increments)    T2: SCON MSCON SSEL XSEL-P/Q XSEL-RA/S    N : None P : 1m S : 3m M : 5m X <input type="checkbox"/> : Specified Length R <input type="checkbox"/> : Robot Cable
	Refer to Options table below.

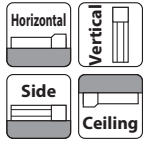

\* Depending on the model, there may be some limitations to using the vertical, side, and ceiling mount positions. Please refer to the Selection Notes on P.138 for more information.

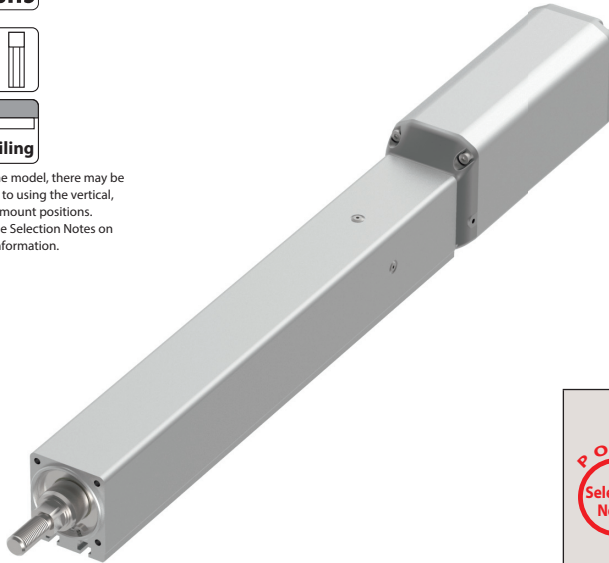

**POINT Selection Notes**

- Both the horizontal and vertical payloads assume operation at an acceleration of 0.3G.
- When the acceleration is increased, the payload will be reduced. Please refer to "Table of Payload by Acceleration" on P.139 for more details.
- Estimated allowable duty varies depending on operating conditions (payload, acceleration/deceleration, etc.). Please refer to P. 149 for more information.
- The value of the horizontal payload assumes that there is an external guide. Please be aware that the anti-rotation stopper can be damaged when an external force is applied to the rod from any direction other than the moving direction.

## Actuator Specifications

### Lead and Payload

Model Number	Motor wattage (W)	Lead (mm)	Max. payload		Rated thrust (N)	Stroke (mm)
			Horizontal (kg)	Vertical (kg)		
RCS4-RA4C-WA-60-16-①-T2-②-③	60	16	8	2	53	50~200 (50mm increments)
RCS4-RA4C-WA-60-10-①-T2-②-③		10	18	4	85	
RCS4-RA4C-WA-60-5-①-T2-②-③		5	30	6	170	
RCS4-RA4C-WA-60-2.5-①-T2-②-③		2.5	40	10	340	

Legend: ① Stroke ② Cable Length ③ Option

### Stroke and Max Speed (Unit: mm/s)

Lead	Stroke	50~200 (50mm increments)
16		800
10		500
5		250
2.5		125

### ① Stroke

① Stroke (mm)	RCS4-RA4C	① Stroke (mm)	RCS4-RA4C
50	○	150	○
100	○	200	○

### ② Cable Length

Type	Cable Code
Standard	P(1m)
	S(3m)
	M(5m)
Specified length (Standard cable)	X06(6m) ~ X10(10m)
	X11(11m) ~ X15(15m)
	X16(16m) ~ X20(20m)
Robot cable	R01(1m) ~ R03(3m)
	R04(4m) ~ R05(5m)
	R06(6m) ~ R10(10m)
	R11(11m) ~ R15(15m)
	R16(16m) ~ R20(20m)

### ③ Options

Name	Option Code	Reference Page
Brake	<b>B</b>	See P.131
Cable exit direction (Top)	<b>CJT</b>	See P.131
Cable exit direction (Right)	<b>CJR</b>	See P.131
Cable exit direction (Left)	<b>CJL</b>	See P.131
Cable exit direction (Bottom)	<b>CJB</b>	See P.131
Flange	<b>FL</b>	See P.132
Foot bracket	<b>FT</b>	See P.133
Tip adapter (Internal thread)	<b>NFA</b>	See P.135
Non-motor end specification	<b>NM</b>	See P.136
T-slot nut bar	<b>NTB</b>	See P.136

### Actuator Specifications

Item	Description
Drive system	Ball screw φ8mm, rolled C10
Positioning repeatability	±0.01mm
Lost motion	0.1mm or less
Rod	φ20mm Material: Aluminum with hard alumite treatment
Allowable static torque on rod tip	1.0N·m
Max. angular displacement on rod tip (*1)	±1.0 deg.
Ambient operating temp. & humidity	0~40°C, 85% RH or less (Non-condensing)

(\*1) This is the displacement angle of the rod tip (initial reference value) when the rod tip is fully retracted and the allowable static torque is applied at the rod tip.

CAD drawings can be downloaded from our website.  
www.intelligentactuator.com



\*1 When the rod is returning to its home position, please be careful of interference from surrounding objects, as it will travel until it reaches the M.E.  
M.E: Mechanical end S.E: Stroke end  
\*2 The direction of width across flat varies depending on the product. Those flats cannot be used for vertical or horizontal reference plane.

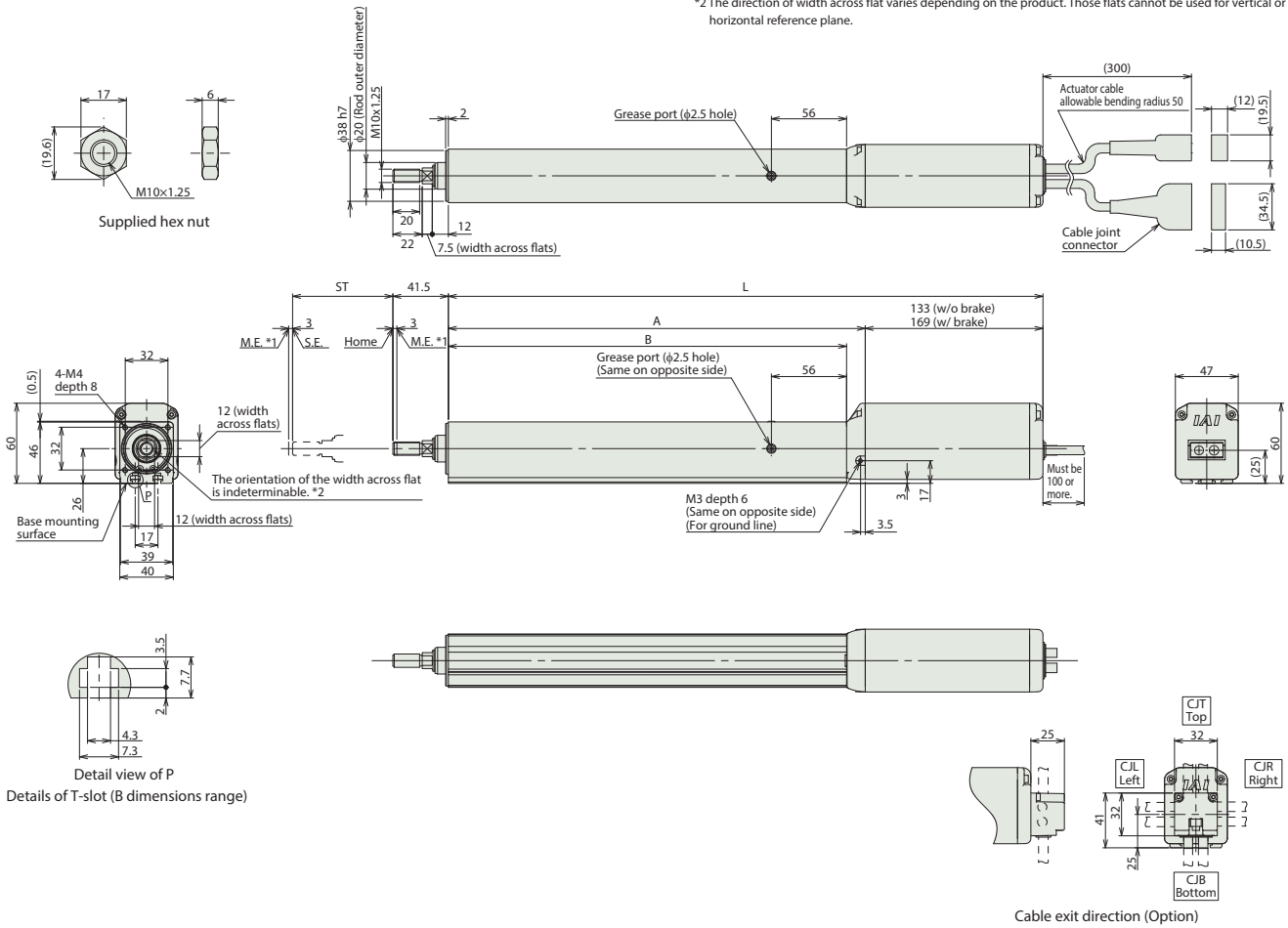

Foreword  
Slider Type  
Wide Slider Type  
Rod Type  
Radial Cylinder  
Wide Radial Cylinder  
Table Type  
Cleanroom Slider  
Cleanroom Wide Slider  
Options  
Reference Data  
Controller

Dimensions and Mass by Stroke

Stroke	50	100	150	200	
	L	W/o brake	295	345	395
	W/ brake	331	381	431	481
	A	162	212	262	312
	B	148	198	248	298
Mass (kg)	W/o brake	1.5	1.7	1.9	2.0
	W/ brake	1.7	1.9	2.1	2.2

Applicable Controllers

The RCS4 series actuators can be operated by the controllers indicated below. Please select the type depending on your intended use.

Name	External view	Max. number of connectable axes	Input power	Control method				Maximum number of positioning points	Reference page	
				Positioner	Pulse train	Program	Network * Option			
SCON-CB/CGB		1	Single phase 100V/200VAC	●	●	—	DeviceNet CC-Link CompoNet MECHATROLINK EtherCAT EtherNet/IP	512 (768 for network spec.)	Please contact IAI for more information.	
SCON-LC/LCG		1		—	—	●		512 (768 for network spec.)		
SCON-CAL/CGAL		1		—	—	—		512 (768 for network spec.)		
MSCON-C		6		This model is network-compatible only.				256		
SSEL-CS		2		●	—	●		20000		
XSEL-P/Q/RA/SA		8	Single phase 200VAC Three-phase 200VAC	—	—	●	55000 (Depending on the type)			

Note:  
The type of compatible networks will vary depending on the controller. Please refer to the reference page for more information.

# RCS4-RA6C

Battery-less Absolute

Motor Unit Type

Coupled Motor

Body Width **60 mm**

**200v** AC Servo Motor

Model Specification Items	<b>RCS4</b> — <b>RA6C</b> — <b>WA</b> — <b>100</b> — <input type="checkbox"/> — <input type="checkbox"/> — <b>T2</b> — <input type="checkbox"/> — <input type="checkbox"/>
	Series — Type — Encoder Type — Motor Type — Lead — Stroke — Applicable Controllers — Cable Length — Options
	WA: Battery-less Absolute    100: Servo motor 100W    20:20mm 12:12mm 6: 6mm 3: 3mm    50:50mm 300:300mm (50mm increments)    T2:SCON MSCON SSEL XSEL-P/Q XSEL-RA/SA    N : None P : 1m S : 3m M : 5m    Refer to Options table below. X <input type="checkbox"/> : Specified Length R <input type="checkbox"/> : Robot Cable

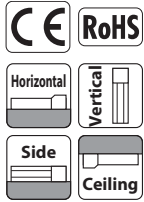

\* Depending on the model, there may be some limitations to using the vertical, side, and ceiling mount positions. Please refer to the Selection Notes on P.138 for more information.

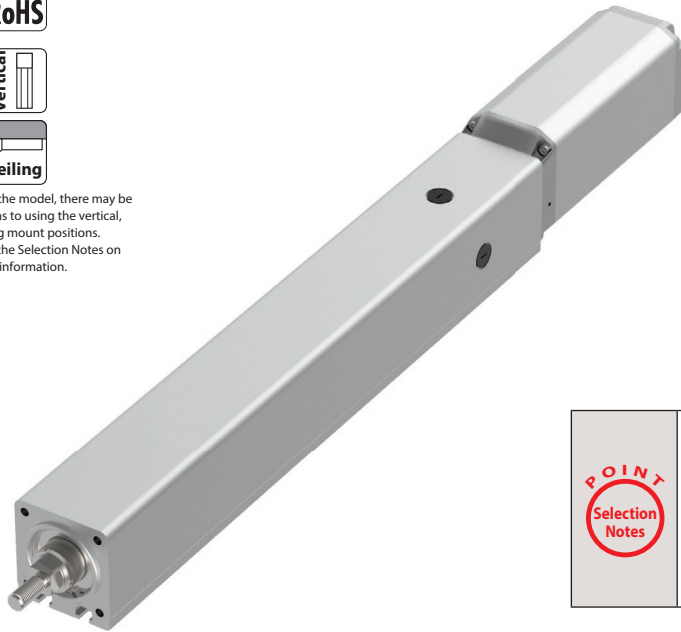

**POINT Selection Notes**

- Both the horizontal and vertical payloads assume operation at an acceleration of 0.3G.
- When the acceleration is increased, the payload will be reduced. Please refer to "Table of Payload by Acceleration" on P.139 for more details.
- Estimated allowable duty varies depending on operating conditions (payload, acceleration/deceleration, etc.). Please refer to P.149 for more information.
- The value of the horizontal payload assumes that there is an external guide. Please be aware that the anti-rotation stopper can be damaged when an external force is applied to the rod from any direction other than the moving direction.

## Actuator Specifications

### Lead and Payload

Model Number	Motor wattage (W)	Lead (mm)	Max. payload		Rated thrust (N)	Stroke (mm)
			Horizontal (kg)	Vertical (kg)		
RCS4-RA6C-WA-100-20-①-T2-②-③	100	20	15	4	85	50~300 (50mm increments)
RCS4-RA6C-WA-100-12-①-T2-②-③		12	25	10	142	
RCS4-RA6C-WA-100-6-①-T2-②-③		6	50	20	283	
RCS4-RA6C-WA-100-3-①-T2-②-③		3	60	20	566	

Legend: ① Stroke ② Cable Length ③ Option

### Stroke and Max Speed (Unit: mm/s)

Lead	Stroke	50~300 (50mm increments)
20		1000
12		600
6		300
3		150

### ① Stroke

① Stroke (mm)	RCS4-RA6C	① Stroke (mm)	RCS4-RA6C
50	○	200	○
100	○	250	○
150	○	300	○

### ② Cable Length

Type	Cable Code
Standard	P(1m)
	S(3m)
	M(5m)
Specified length (Standard cable)	X06(6m) ~ X10(10m)
	X11(11m) ~ X15(15m)
	X16(16m) ~ X20(20m)
Robot cable	R01(1m) ~ R03(3m)
	R04(4m) ~ R05(5m)
	R06(6m) ~ R10(10m)
	R11(11m) ~ R15(15m)
	R16(16m) ~ R20(20m)

### ③ Options

Name	Option Code	Reference Page
Brake	<b>B</b>	See P.131
Cable exit direction (Top)	<b>CJT</b>	See P.131
Cable exit direction (Right)	<b>CJR</b>	See P.131
Cable exit direction (Left)	<b>CJL</b>	See P.131
Cable exit direction (Bottom)	<b>CJB</b>	See P.131
Flange	<b>FL</b>	See P.132
Foot bracket	<b>FT</b>	See P.133
Tip adapter (Internal thread)	<b>NFA</b>	See P.135
Non-motor end specification	<b>NM</b>	See P.136
T-slot nut bar	<b>NTB</b>	See P.136

### Actuator Specifications

Item	Description
Drive system	Ball screw φ10mm, rolled C10
Positioning repeatability	±0.01mm
Lost motion	0.1 mm or less
Rod	φ25mm Material: Aluminum with hard alumite treatment
Allowable static torque on rod tip	1.5N·m
Max. angular displacement on rod tip (*1)	±1.0 deg.
Ambient operating temp. & humidity	0~40°C, 85% RH or less (Non-condensing)

(\*1) This is the displacement angle of the rod tip (initial reference value) when the rod tip is fully retracted and the allowable static torque is applied at the rod tip.



\*1 When the rod is returning to its home position, please be careful of interference from surrounding objects, as it will travel until it reaches the M.E.  
M.E: Mechanical end S.E: Stroke end  
\*2 The direction of width across flat varies depending on the product. Those flats cannot be used for vertical or horizontal reference plane.

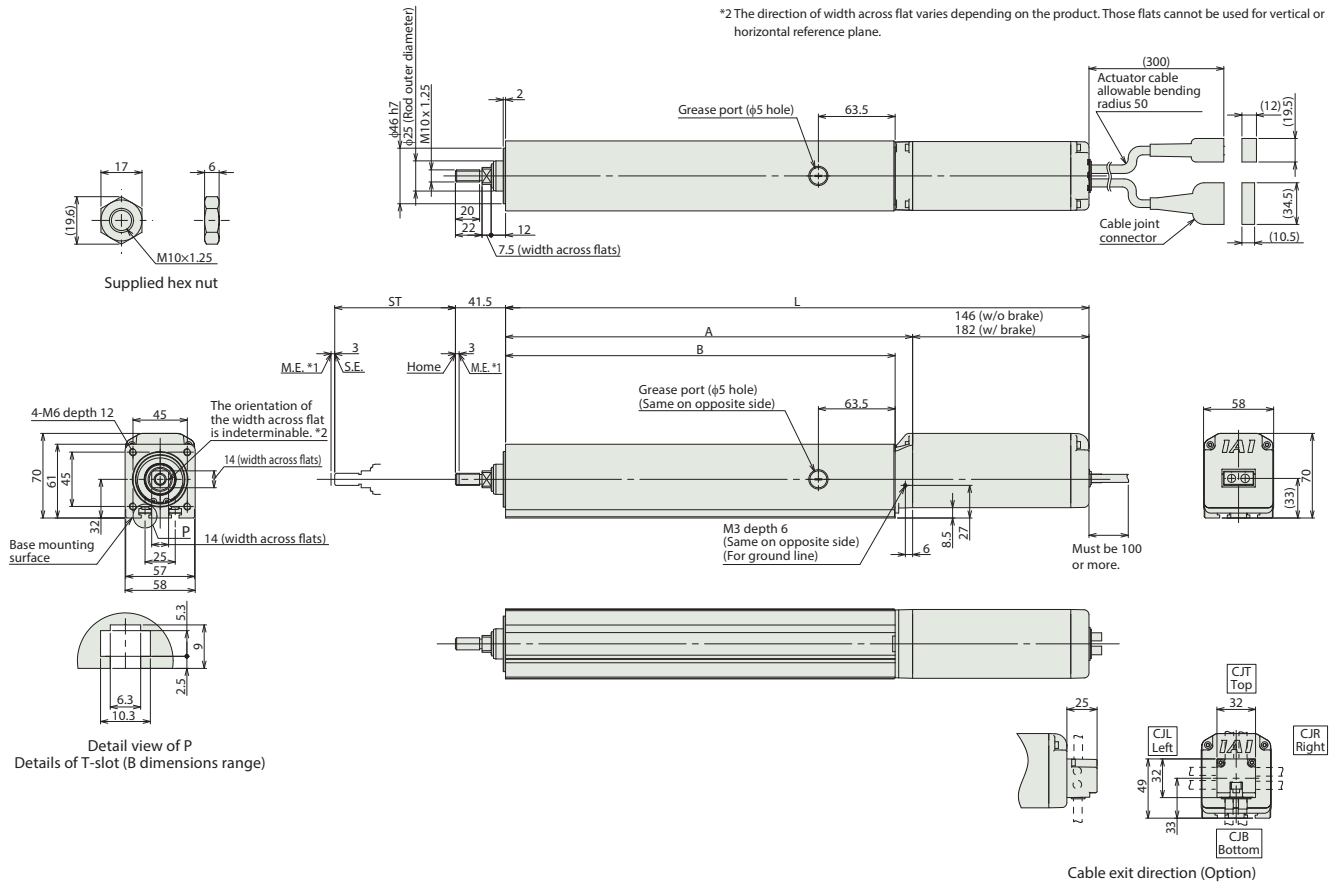

Dimensions and Mass by Stroke

L	Stroke	50	100	150	200	250	300
	W/o brake	333	383	433	483	533	583
	W/ brake	369	419	469	519	569	619
	A	187	237	287	337	387	437
	B	172.5	222.5	272.5	322.5	372.5	422.5
Mass (kg)	W/o brake	2.6	3.0	3.4	3.8	4.1	4.5
	W/ brake	2.9	3.3	3.7	4.1	4.4	4.8

Applicable Controllers

The RCS4 series actuators can be operated by the controllers indicated below. Please select the type depending on your intended use.

Name	External view	Max. number of connectable axes	Input power	Control method				Maximum number of positioning points	Reference page	
				Positioner	Pulse train	Program	Network * Option			
SCON-CB/CGB		1	Single phase 100V/200VAC	●	●	—	DeviceNet CC-Link CompoNet MECHATROLINK EtherCAT EtherNet/IP	512 (768 for network spec.)	Please contact IAI for more information.	
SCON-LC/LCG		1		—	—	●		512 (768 for network spec.)		
SCON-CAL/CGAL		1		●	—	—		512 (768 for network spec.)		
MSCON-C		6		This model is network-compatible only.				256		
SSEL-CS		2		●	—	●		20000		
XSEL-P/Q/RA/SA		8	Single phase 200VAC Three-phase 200VAC	—	—	●	55000 (Depending on the type)			

Note: The type of compatible networks will vary depending on the controller. Please refer to the reference page for more information.

Foreword  
Slider Type  
Wide Slider Type  
Rod Type  
Radial Cylinder  
Wide Radial Cylinder  
Table Type  
Cleanroom Slider  
Cleanroom Wide Slider  
Options  
Reference Data  
Controller

# RCS4-RA7C

Battery-less Absolute

Motor Unit Type

Coupled Motor

Body Width 70 mm

200v AC Servo Motor

Model Specification Items	<b>RCS4</b> — <b>RA7C</b> — <b>WA</b> — <b>200</b> — <input type="checkbox"/> — <input type="checkbox"/> — <input type="checkbox"/> — <input type="checkbox"/> — <input type="checkbox"/> — <input type="checkbox"/>	<b>T2</b> — <input type="checkbox"/> — <input type="checkbox"/>
	Series — Type — Encoder Type — Motor Type — Lead — Stroke — Applicable Controllers — Cable Length — Options	
	WA: Battery-less Absolute	200: Servo motor 200W
	24:24mm 16:16mm 8: 8mm 4: 4mm	50:50mm 300:300mm (50mm increments)
	T2:SCON MSCON SSEL XSEL-P/Q XSEL-RA/SA	N : None P : 1m S : 3m M : 5m X <input type="checkbox"/> : Specified Length R <input type="checkbox"/> : Robot Cable
		Refer to Options table below.

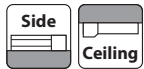

\* Depending on the model, there may be some limitations to using the vertical, side, and ceiling mount positions. Please refer to the Selection Notes on P.138 for more information.

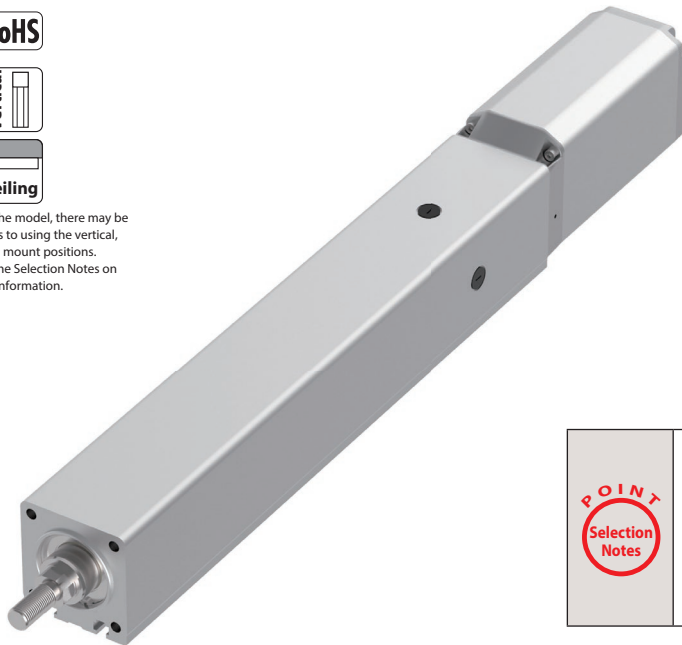

**POINT Selection Notes**

- Both the horizontal and vertical payloads assume operation at an acceleration of 0.3G.
- When the acceleration is increased, the payload will be reduced. Please refer to "Table of Payload by Acceleration" on P.139 for more details.
- Estimated allowable duty varies depending on operating conditions (payload, acceleration/deceleration, etc.). Please refer to P. 149 for more information.
- The value of the horizontal payload assumes that there is an external guide. Please be aware that the anti-rotation stopper can be damaged when an external force is applied to the rod from any direction other than the moving direction.

## Actuator Specifications

### Lead and Payload

Model Number	Motor wattage (W)	Lead (mm)	Max. payload		Rated thrust (N)	Stroke (mm)
			Horizontal (kg)	Vertical (kg)		
RCS4-RA7C-WA-200-24-①-T2-②-③	200	24	20	6	142	50~300 (50mm increments)
RCS4-RA7C-WA-200-16-①-T2-②-③		16	45	12	214	
RCS4-RA7C-WA-200-8-①-T2-②-③		8	60	25	427	
RCS4-RA7C-WA-200-4-①-T2-②-③		4	80	35	855	

Legend: ① Stroke ② Cable Length ③ Option

### Stroke and Max Speed (Unit: mm/s)

Lead	Stroke	
	50~300 (50mm increments)	50~300 (50mm increments)
24		1200
16		800
8		400
4		200

### ① Stroke

① Stroke (mm)	RCS4-RA7C	① Stroke (mm)	RCS4-RA7C
50	○	200	○
100	○	250	○
150	○	300	○

### ② Cable Length

Type	Cable Code
Standard	P(1m)
	S(3m)
	M(5m)
Specified length (Standard cable)	X06(6m) ~ X10(10m)
	X11(11m) ~ X15(15m)
	X16(16m) ~ X20(20m)
Robot cable	R01(1m) ~ R03(3m)
	R04(4m) ~ R05(5m)
	R06(6m) ~ R10(10m)
	R11(11m) ~ R15(15m)
	R16(16m) ~ R20(20m)

### ③ Options

Name	Option Code	Reference Page
Brake	<b>B</b>	See P.131
Cable exit direction (Top)	<b>CJT</b>	See P.131
Cable exit direction (Right)	<b>CJR</b>	See P.131
Cable exit direction (Left)	<b>CJL</b>	See P.131
Cable exit direction (Bottom)	<b>CJB</b>	See P.131
Flange	<b>FL</b>	See P.132
Foot bracket	<b>FT</b>	See P.133
Tip adapter (Internal thread)	<b>NFA</b>	See P.135
Non-motor end specification	<b>NM</b>	See P.136
T-slot nut bar	<b>NTB</b>	See P.136

### Actuator Specifications

Item	Description
Drive system	Ball screw φ12mm, rolled C10
Positioning repeatability	±0.01mm
Lost motion	0.1 mm or less
Rod	φ30mm Material: Aluminum with hard alumite treatment
Allowable static torque on rod tip	2.5N·m
Max. angular displacement on rod tip (*1)	±0.8 deg.
Ambient operating temp. & humidity	0~40°C, 85% RH or less (Non-condensing)

(\*1) This is the displacement angle of the rod tip (initial reference value) when the rod tip is fully retracted and the allowable static torque is applied at the rod tip.





\*1 When the rod is returning to its home position, please be careful of interference from surrounding objects, as it will travel until it reaches the M.E.  
M.E: Mechanical end S.E: Stroke end  
\*2 The direction of width across flat varies depending on the product. Those flats cannot be used for vertical or horizontal reference plane.

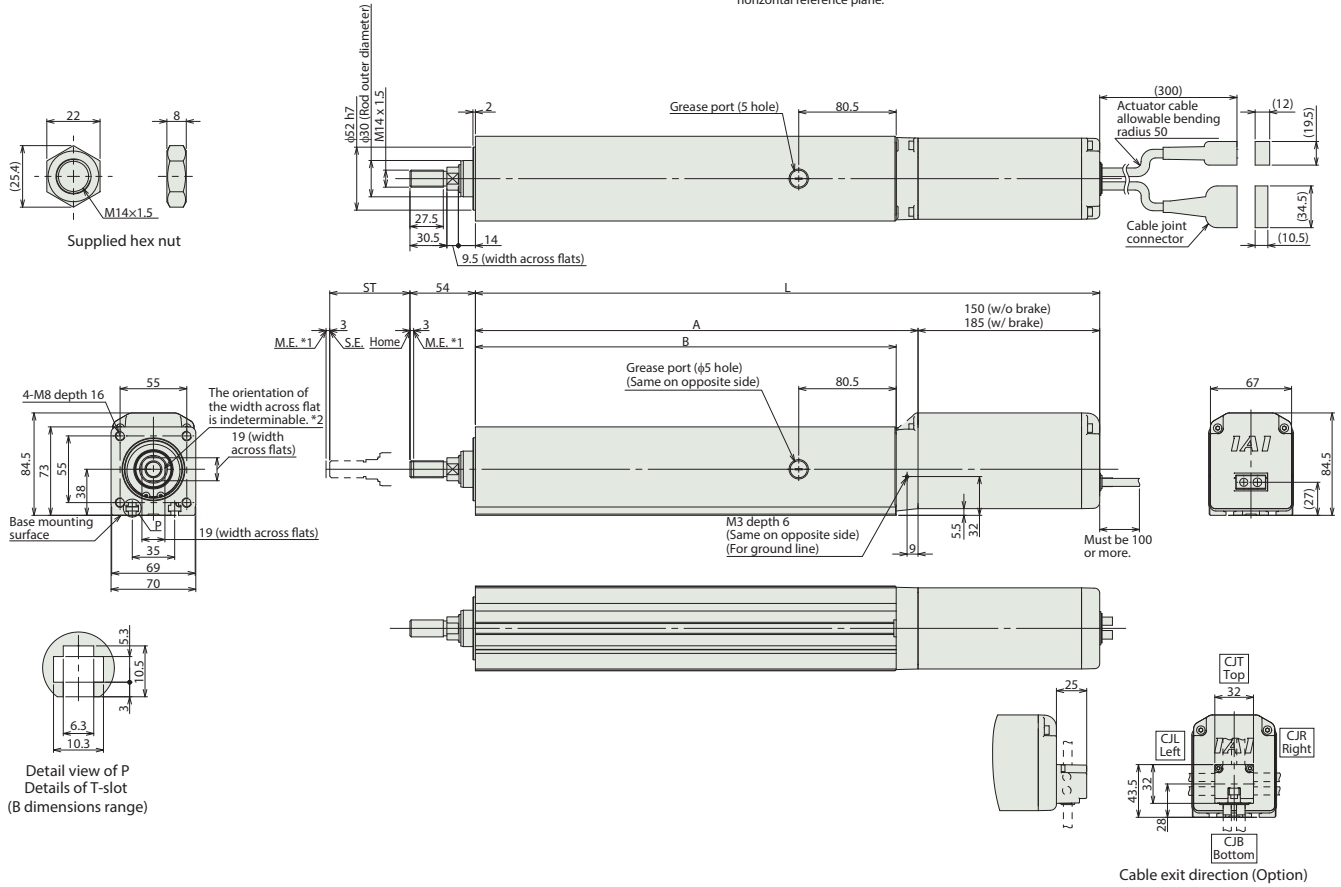

**Dimensions and Mass by Stroke**

L	Stroke	50	100	150	200	250	300
	W/o brake	365.5	415.5	465.5	515.5	565.5	615.5
W/ brake	400.5	450.5	500.5	550.5	600.5	650.5	
A	215.5	265.5	315.5	365.5	415.5	465.5	
B	197.5	247.5	297.5	347.5	397.5	447.5	
Mass (kg)	W/o brake	4.6	5.2	5.7	6.3	6.9	7.5
	W/ brake	5.1	5.7	6.2	6.8	7.4	8.0

**Applicable Controllers**

The RCS4 series actuators can be operated by the controllers indicated below. Please select the type depending on your intended use.

Name	External view	Max. number of connectable axes	Input power	Control method				Maximum number of positioning points	Reference page
				Positioner	Pulse train	Program	Network * Option		
SCON-CB/CGB		1	Single phase 100V/200VAC	●	●	—	  	512 (768 for network spec.)	Please contact IAI for more information.
SCON-LC/LCG		1		—	—	●		 	
SCON-CAL/CGAL		1		This model is network-compatible only.					
MSCON-C		6						256	
SSEL-CS		2		●	—	●	20000		
XSEL-P/Q/RA/SA		8	Single phase 200VAC Three-phase 200VAC	—	—	●	55000 (Depending on the type)		

Note:  
The type of compatible networks will vary depending on the controller. Please refer to the reference page for more information.

Foreword  
Slider Type  
Wide Slider Type  
Rod Type  
Radial Cylinder  
Wide Radial Cylinder  
Table Type  
Cleanroom Slider  
Cleanroom Wide Slider  
Options  
Reference Data  
Controller

# RCS4-RA8C

Battery-less Absolute

Motor Unit Type

Coupled Motor

Body Width **90 mm**

**200v** AC Servo Motor

Model Specification Items	<b>RCS4</b> — <b>RA8C</b> — <b>WA</b> — <b>400</b> — <input type="checkbox"/> — <input type="checkbox"/> — <b>T2</b> — <input type="checkbox"/> — <input type="checkbox"/>
	Series — Type — Encoder Type — Motor Type — Lead — Stroke — Applicable Controllers — Cable Length — Options
	WA: Battery-less Absolute    400: Servo motor 400W    20:20mm 10:10mm 5: 5mm    50:50mm 300:300mm (50mm increments)    T2:SCON SSEL XSEL-P/Q XSEL-RA/SA    N : None P : 1m S : 3m M : 5m    Refer to Options table below.    X <input type="checkbox"/> : Specified Length R <input type="checkbox"/> : Robot Cable

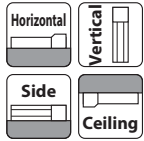

\* Depending on the model, there may be some limitations to using the vertical, side, and ceiling mount positions. Please refer to the Selection Notes on P.138 for more information.

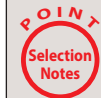

- (1) Both the horizontal and vertical payloads assume operation at an acceleration of 0.3G. (0.2G for vertical lead 5).
- (2) When the acceleration is increased, the payload will be reduced. Please refer to "Table of Payload by Acceleration" on P.139 for more details.
- (3) Estimated allowable duty varies depending on operating conditions (payload, acceleration/deceleration, etc.). Please refer to P. 149 for more information.
- (4) The value of the horizontal payload assumes that there is an external guide. Please be aware that the anti-rotation stopper can be damaged when an external force is applied to the rod from any direction other than the moving direction.

## Actuator Specifications

### Lead and Payload

Model Number	Motor wattage (W)	Lead (mm)	Max. payload		Rated thrust (N)	Stroke (mm)
			Horizontal (kg)	Vertical (kg)		
RCS4-RA8C-WA-400-20-①-T2-②-③	400	20	60	20	339	50~300 (50mm increments)
RCS4-RA8C-WA-400-10-①-T2-②-③		10	80	40	678	
RCS4-RA8C-WA-400-5-①-T2-②-③		5	100	72	1357	

Legend: ① Stroke ② Cable Length ③ Option

### Stroke and Max Speed (Unit: mm/s)

Lead	Stroke	50~300 (50mm increments)
	20	1000
10	500	500
5	250	250

### ① Stroke

① Stroke (mm)	RCS4-RA8C	① Stroke (mm)	RCS4-RA8C
50	<input type="checkbox"/>	200	<input type="checkbox"/>
100	<input type="checkbox"/>	250	<input type="checkbox"/>
150	<input type="checkbox"/>	300	<input type="checkbox"/>

### ② Cable Length

Type	Cable Code
Standard	P(1m)
	S(3m)
	M(5m)
Specified length (Standard cable)	X06(6m) ~ X10(10m)
	X11(11m) ~ X15(15m)
	X16(16m) ~ X20(20m)
Robot cable	R01(1m) ~ R03(3m)
	R04(4m) ~ R05(5m)
	R06(6m) ~ R10(10m)
	R11(11m) ~ R15(15m)
	R16(16m) ~ R20(20m)
	R21(21m) ~ R25(25m)

### ③ Options

Name	Option Code	Reference Page
Brake	<b>B</b>	See P.131
Cable exit direction (Top)	<b>CJT</b>	See P.131
Cable exit direction (Right)	<b>CJR</b>	See P.131
Cable exit direction (Left)	<b>CJL</b>	See P.131
Cable exit direction (Bottom)	<b>CJB</b>	See P.131
Flange	<b>FL</b>	See P.132
Foot bracket	<b>FT</b>	See P.133
Tip adapter (Internal thread)	<b>NFA</b>	See P.135
Non-motor end specification	<b>NM</b>	See P.136
T-slot nut bar	<b>NTB</b>	See P.136

### Actuator Specifications

Item	Description
Drive system	Ball screw φ16mm, rolled C10
Positioning repeatability	±0.01mm
Lost motion	0.1 mm or less
Rod	φ40mm Material: Aluminum with hard alumite treatment
Allowable static torque on rod tip	5.0N·m
Max. angular displacement on rod tip (*1)	±0.8 deg.
Ambient operating temp. & humidity	0~40°C, 85% RH or less (Non-condensing)

(\*1) This is the displacement angle of the rod tip (initial reference value) when the rod tip is fully retracted and the allowable static torque is applied at the rod tip.



\*1 When the rod is returning to its home position, please be careful of interference from surrounding objects, as it will travel until it reaches the M.E.  
M.E: Mechanical end S.E: Stroke end  
\*2 The direction of width across flat varies depending on the product. Those flats cannot be used for vertical or horizontal reference plane.

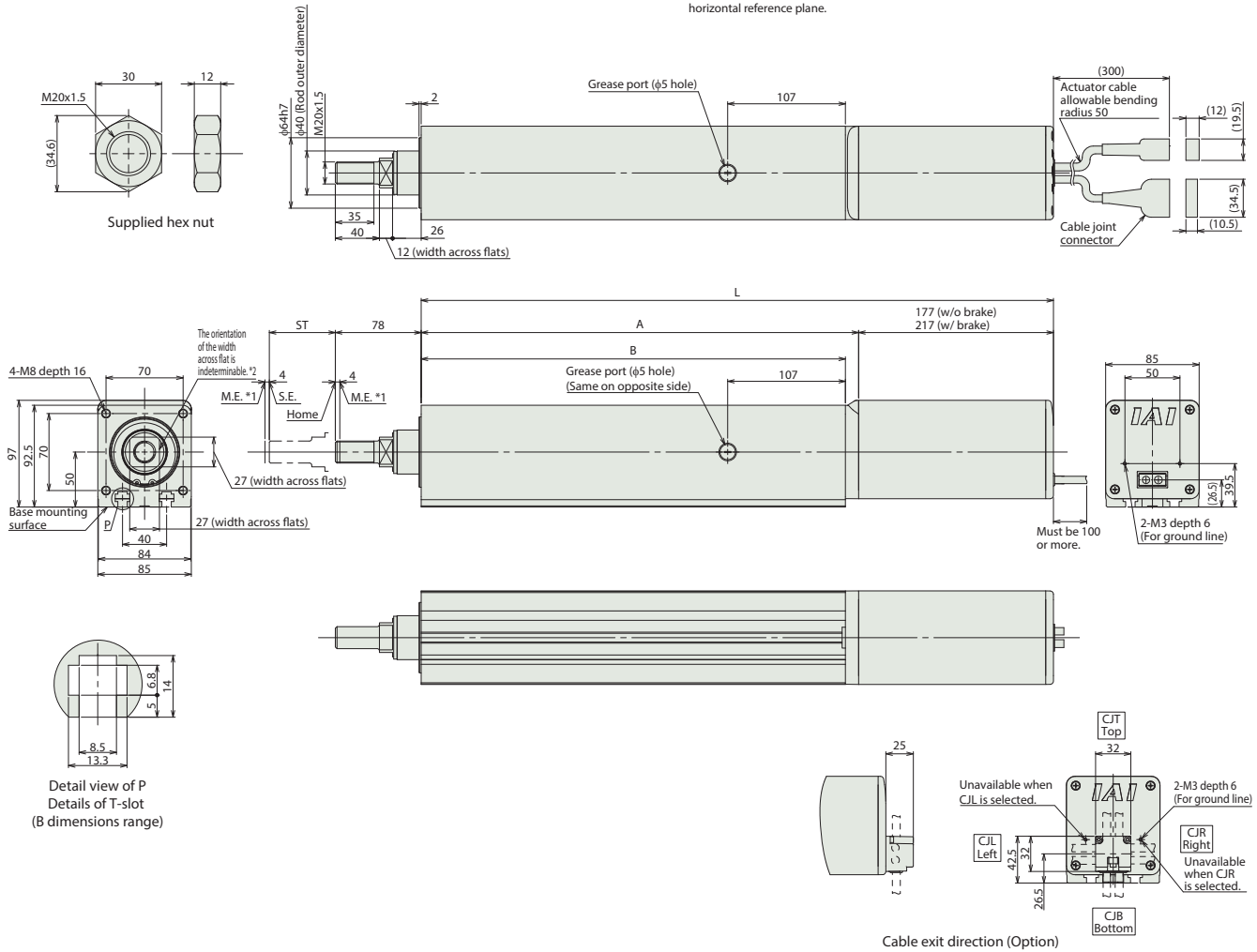

**Dimensions and Mass by Stroke**

Stroke	50	100	150	200	250	300
	L	424.5	474.5	524.5	574.5	624.5
W/o brake	464.5	514.5	564.5	614.5	664.5	714.5
W/ brake	247.5	297.5	347.5	397.5	447.5	497.5
A	235.5	285.5	335.5	385.5	435.5	485.5
B	8.3	9.2	10.0	10.8	11.7	12.5
Mass (kg)	8.9	9.8	10.6	11.4	12.3	13.1

**Applicable Controllers**

The RCS4 series actuators can be operated by the controllers indicated below. Please select the type depending on your intended use.

Name	External view	Max. number of connectable axes	Input power	Control method				Maximum number of positioning points	Reference page
				Positioner	Pulse train	Program	Network * Option		
SCON-CB/CGB		1	Single phase 200VAC	●	●	-	<b>DeviceNet</b> <b>CC-Link</b> <b>PROFINET</b> <b>CompoNet</b> <b>MECHATROLINK</b> <b>EtherCAT</b> <b>EtherNet/IP</b>	512 (768 for network spec.)	Please contact IAI for more information.
SCON-LC/LCG		1		-	-	●		512 (768 for network spec.)	
SSEL-CS		2	Single phase 100V/200VAC	●	-	●	20000		
XSEL-P/Q/RA/SA		8	Single phase 200VAC Three-phase 200VAC	-	-	●	55000 (Depending on the type)		

Note:  
The type of compatible networks will vary depending on the controller. Please refer to the reference page for more information.

# RCS4-RA4R

Battery-less Absolute

Motor Unit Type

Side-mounted Motor

Body Width 40\* mm

200v AC Servo Motor

<b>Model Specification Items</b>	<b>RCS4</b> — <b>RA4R</b> — <b>WA</b> — <b>60</b> — <input type="checkbox"/> — <input type="checkbox"/> — <input type="checkbox"/> — <input type="checkbox"/> — <input type="checkbox"/> — <input type="checkbox"/>	<b>T2</b> — <input type="checkbox"/> — <input type="checkbox"/>	<small>* Body width does not include the width of the side-mounted motor.</small>
	Series — Type — Encoder Type — Motor Type — Lead — Stroke —	Applicable Controllers — Cable Length — Options	
	WA: Battery-less Absolute	60: Servo motor 60W	16: 16mm 10: 10mm 5: 5mm 2.5: 2.5mm
			50: 50mm 200: 200mm (50mm increments)
			T2: SCON MCON SSEL XSEL-P/Q XSEL-RA/SA
			N : None P : 1m S : 3m M : 5m X <input type="checkbox"/> : Specified Length R <input type="checkbox"/> : Robot Cable

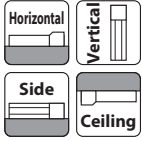

\* Depending on the model, there may be some limitations to using the vertical, side, and ceiling mount positions. Please refer to the Selection Notes on P.138 for more information.

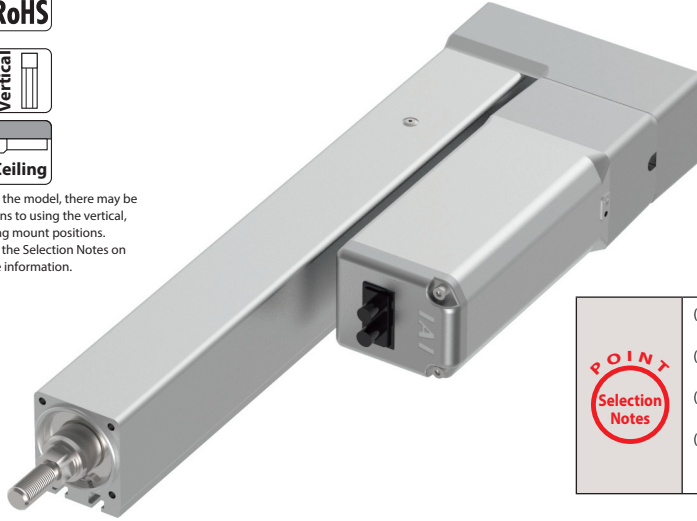

	(1) Both the horizontal and vertical payloads assume operation at an acceleration of 0.3G.
	(2) When the acceleration is increased, the payload will be reduced. Please refer to "Table of Payload by Acceleration" on P.139 for more details.
	(3) Estimated allowable duty varies depending on operating conditions (payload, acceleration/deceleration, etc.). Please refer to P. 149 for more information.
	(4) The value of the horizontal payload assumes that there is an external guide. Please be aware that the anti-rotation stopper can be damaged when an external force is applied to the rod from any direction other than the moving direction.

## Actuator Specifications

### Lead and Payload

Model Number	Motor wattage (W)	Lead (mm)	Max. payload		Rated thrust (N)	Stroke (mm)
			Horizontal (kg)	Vertical (kg)		
RCS4-RA4R-WA-60-16-①-T2-②-③	60	16	8	2	53	50~200 (50mm increments)
RCS4-RA4R-WA-60-10-①-T2-②-③		10	18	4	85	
RCS4-RA4R-WA-60-5-①-T2-②-③		5	30	6	170	
RCS4-RA4R-WA60-2.5-①-T2-②-③		2.5	40	10	340	

Legend: ① Stroke ② Cable Length ③ Option

### Stroke and Max Speed (Unit: mm/s)

Lead	Stroke	50~200 (50mm increments)
		16
10	500	
5	250	
2.5	125	

### ① Stroke

① Stroke (mm)	RCS4-RA4R	① Stroke (mm)	RCS4-RA4R
50	<input type="radio"/>	150	<input type="radio"/>
100	<input type="radio"/>	200	<input type="radio"/>

### ② Cable Length

Type	Cable Code
Standard	P(1m)
	S(3m)
	M(5m)
Specified length (Standard cable)	X06(6m) ~ X10(10m)
	X11(11m) ~ X15(15m)
	X16(16m) ~ X20(20m)
Robot cable	R01(1m) ~ R03(3m)
	R04(4m) ~ R05(5m)
	R06(6m) ~ R10(10m)
	R11(11m) ~ R15(15m)
	R16(16m) ~ R20(20m)

### ③ Options

Name	Option Code	Reference Page
Brake	B	See P.131
Cable exit direction (Top)	CJT	See P.131
Cable exit direction (Bottom)	CJB	See P.131
Cable exit direction (Outside)	CJO	See P.131
Flange	FL	See P.132
Foot bracket	FT	See P.133
Motor side-mounted to left (standard)	ML	See P.135
Motor side-mounted to right	MR	See P.135
Tip adapter (Internal thread)	NFA	See P.135
Non-motor end specification	NM	See P.136
T-slot nut bar specification	NTB	See P.136
Back mounting plate	RP	See P.137

### Actuator Specifications

Item	Description
Drive system	Ball screw $\phi$ 8mm, rolled C10
Positioning repeatability	$\pm$ 0.01mm
Lost motion	0.1mm or less
Rod	$\phi$ 20mm Material: Aluminum with hard alumite treatment
Allowable static torque on rod tip	1.0N·m
Max. angular displacement on rod tip (*1)	$\pm$ 1.0 deg.
Ambient operating temp. & humidity	0~40°C, 85% RH or less (Non-condensing)

(\*1) This is the displacement angle of the rod tip (initial reference value) when the rod tip is fully retracted and the allowable static torque is applied at the rod tip.



\*1 When the rod is returning to its home position, please be careful of interference from surrounding objects, as it will travel until it reaches the M.E.  
M.E: Mechanical end S.E: Stroke end  
\*2 The direction of width across flat varies depending on the product. Those flats cannot be used for vertical or horizontal reference plane.

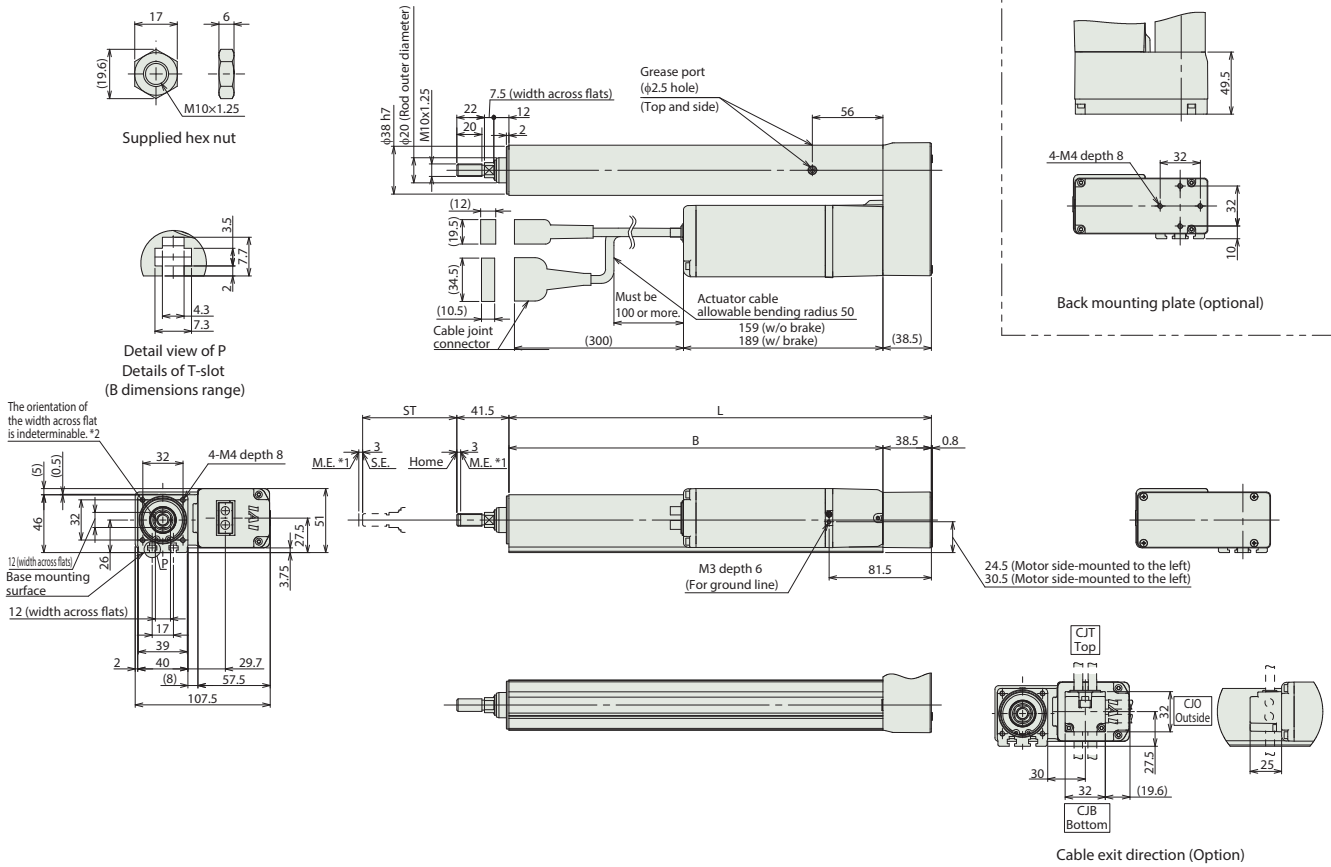

■ Dimensions and Mass by Stroke

Stroke	50	100	150	200	
L	186.5	236.5	286.5	336.5	
B	148	198	248	298	
Mass (kg)	W/o brake	1.8	2.0	2.1	2.3
	W/ brake	2.0	2.2	2.3	2.5

Applicable Controllers

The RCS4 series actuators can be operated by the controllers indicated below. Please select the type depending on your intended use.

Name	External view	Max. number of connectable axes	Input power	Control method				Maximum number of positioning points	Reference page	
				Positioner	Pulse train	Program	Network * Option			
SCON-CB/CGB		1	Single phase 100V/200VAC	●	●	—	DeviceNet CC-Link CC-Link IE CompoNet MECHATROLINK EtherCAT EtherNet/IP EtherCAT	512 (768 for network spec.)	Please contact IAI for more information.	
SCON-LC/LCG		1		—	—	●		512 (768 for network spec.)		
SCON-CAL/CGAL		1		●	—	—		512 (768 for network spec.)		
MSCON-C		6		This model is network-compatible only.				256		
SSEL-CS		2		●	—	●		20000		
XSEL-P/Q/RA/SA		8	Single phase 200VAC Three-phase 200VAC	—	—	●	55000 (Depending on the type)			

Note: The type of compatible networks will vary depending on the controller. Please refer to the reference page for more information.

Foreword  
Slider Type  
Wide Slider Type  
Rod Type  
Radial Cylinder  
Wide Radial Cylinder  
Table Type  
Cleanroom Slider  
Cleanroom Wide Slider  
Options  
Reference Data  
Controller

# RCS4-RA6R

Battery-less Absolute

Motor Unit Type

Side-mounted Motor

Body Width 60\* mm

200v AC Servo Motor

Model Specification Items	<b>RCS4</b> — <b>RA6R</b> — <b>WA</b> — <b>100</b> — <input type="checkbox"/> — <input type="checkbox"/> — <input type="checkbox"/>	<b>T2</b> — <input type="checkbox"/> — <input type="checkbox"/>	* Body width does not include the width of the side-mounted motor.
Series	Type	Encoder Type	Motor Type
WA: Battery-less Absolute	100: Servo motor 100W	20:20mm 12:12mm 6: 6mm 3: 3mm	50:50mm 300:300mm (50mm increments)
Lead	Stroke	Applicable Controllers	Cable Length
		T2:SCON MSCON SSEL XSEL-P/Q XSEL-RA/SA	N : None P : 1m S : 3m M : 5m X <input type="checkbox"/> : Specified Length R <input type="checkbox"/> : Robot Cable
			Options
			Refer to Options table below.



\* Depending on the model, there may be some limitations to using the vertical, side, and ceiling mount positions. Please refer to the Selection Notes on P.138 for more information.



	(1) Both the horizontal and vertical payloads assume operation at an acceleration of 0.3G.
	(2) When the acceleration is increased, the payload will be reduced. Please refer to "Table of Payload by Acceleration" on P.139 for more details.
	(3) Estimated allowable duty varies depending on operating conditions (payload, acceleration/deceleration, etc.). Please refer to P. 149 for more information.
	(4) The value of the horizontal payload assumes that there is an external guide. Please be aware that the anti-rotation stopper can be damaged when an external force is applied to the rod from any direction other than the moving direction.

## Actuator Specifications

### Lead and Payload

Model Number	Motor wattage (W)	Lead (mm)	Max. payload		Rated thrust (N)	Stroke (mm)
			Horizontal (kg)	Vertical (kg)		
RCS4-RA6R-WA-100-20-①-T2-②-③	100	20	15	4	85	50~300 (50mm increments)
RCS4-RA6R-WA-100-12-①-T2-②-③		12	25	9	142	
RCS4-RA6R-WA-100-6-①-T2-②-③		6	50	19	283	
RCS4-RA6R-WA-100-3-①-T2-②-③		3	60	20	566	

Legend: ① Stroke ② Cable Length ③ Option

### Stroke and Max Speed (Unit: mm/s)

Lead	Stroke	50~300 (50mm increments)
20		1000
12		600
6		300
3		150

### ① Stroke

① Stroke (mm)	RCS4-RA6R	① Stroke (mm)	RCS4-RA6R
50	○	200	○
100	○	250	○
150	○	300	○

### ② Cable Length

Type	Cable Code
Standard	P(1m)
	S(3m)
	M(5m)
Specified length (Standard cable)	X06(6m) ~ X10(10m)
	X11(11m) ~ X15(15m)
	X16(16m) ~ X20(20m)
Robot cable	R01(1m) ~ R03(3m)
	R04(4m) ~ R05(5m)
	R06(6m) ~ R10(10m)
	R11(11m) ~ R15(15m)
	R16(16m) ~ R20(20m)

### ③ Options

Name	Option Code	Reference Page
Brake	<b>B</b>	See P.131
Cable exit direction (Top)	<b>CJT</b>	See P.131
Cable exit direction (Bottom)	<b>CJB</b>	See P.131
Cable exit direction (Outside)	<b>CJO</b>	See P.131
Flange	<b>FL</b>	See P.132
Foot bracket	<b>FT</b>	See P.133
Motor side-mounted to left (standard)	<b>ML</b>	See P.135
Motor side-mounted to right	<b>MR</b>	See P.135
Tip adapter (Internal thread)	<b>NFA</b>	See P.135
Non-motor end specification	<b>NM</b>	See P.136
T-slot nut bar specification	<b>NTB</b>	See P.136

### Actuator Specifications

Item	Description
Drive system	Ball screw φ10mm, rolled C10
Positioning repeatability	±0.01mm
Lost motion	0.1mm or less
Rod	φ25mm Material: Aluminum with hard alumite treatment
Allowable static torque on rod tip	1.5N·m
Max. angular displacement on rod tip (*1)	±1.0 deg.
Ambient operating temp. & humidity	0~40°C, 85% RH or less (Non-condensing)

(\*1) This is the displacement angle of the rod tip (initial reference value) when the rod tip is fully retracted and the allowable static torque is applied at the rod tip.

\* Be sure to confirm with the "Selection Notes (P.138)" when selecting options.

CAD drawings can be downloaded from our website.  
www.intelligentactuator.com



\*1 When the rod is returning to its home position, please be careful of interference from surrounding objects, as it will travel until it reaches the M.E.  
M.E: Mechanical end S.E: Stroke end  
\*2 The direction of width across flat varies depending on the product. Those flats cannot be used for vertical or horizontal reference plane.

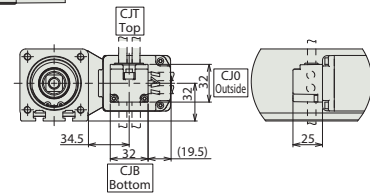
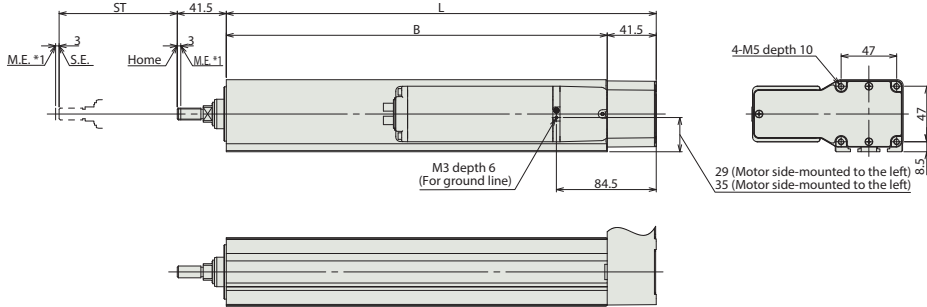
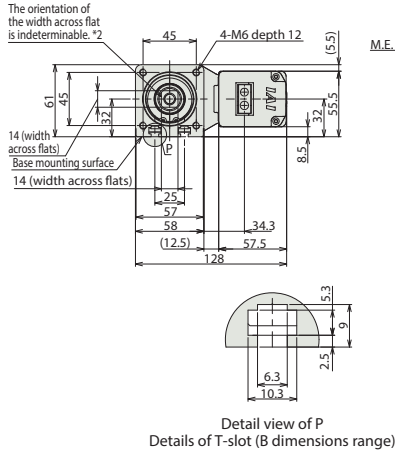
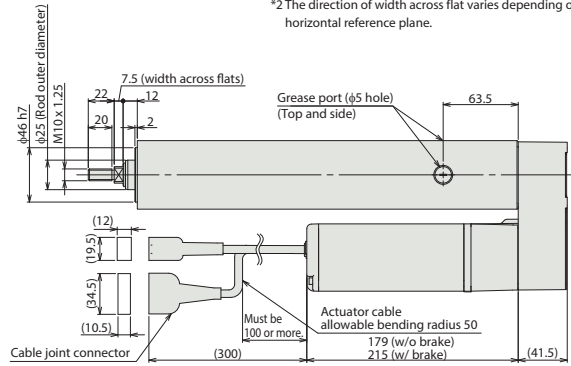
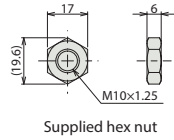

■ Dimensions and Mass by Stroke

Stroke	50	100	150	200	250	300
L	214	264	314	364	414	464
B	172.5	222.5	272.5	322.5	372.5	422.5
Mass (kg)	W/o brake	2.9	3.3	3.7	4.1	4.5
	W/ brake	3.2	3.6	4.0	4.4	4.8

Applicable Controllers

The RCS4 series actuators can be operated by the controllers indicated below. Please select the type depending on your intended use.

Name	External view	Max. number of connectable axes	Input power	Control method				Maximum number of positioning points	Reference page	
				Positioner	Pulse train	Program	Network * Option			
SCON-CB/CGB		1	Single phase 100V/200VAC	●	●	-	DeviceNet CC-Link CompoNet MECHATROLINK EtherCAT EtherNet/IP	512 (768 for network spec.)	Please contact IAI for more information.	
SCON-LC/LCG		1		-	-	●		512 (768 for network spec.)		
SCON-CAL/CGAL		1		●	-	-		512 (768 for network spec.)		
MSCON-C		6		This model is network-compatible only.				256		
SSEL-CS		2		●	-	●		20000		
XSEL-P/Q/RA/SA		8	Single phase 200VAC Three-phase 200VAC	-	-	●	55000 (Depending on the type)			

Note: The type of compatible networks will vary depending on the controller. Please refer to the reference page for more information.

Foreword  
Slider Type  
Wide Slider Type  
Rod Type  
Radial Cylinder  
Wide Radial Cylinder  
Table Type  
Cleanroom Slider  
Cleanroom Wide Slider  
Options  
Reference Data  
Controller

# RCS4-RA7R

Battery-less Absolute

Motor Unit Type

Side-mounted Motor

Body Width 70\* mm

200v AC Servo Motor

Model Specification Items	<b>RCS4</b> — <b>RA7R</b> — <b>WA</b> — <b>200</b> — <input type="checkbox"/> — <input type="checkbox"/> — <b>T2</b> — <input type="checkbox"/> — <input type="checkbox"/>	* Body width does not include the width of the side-mounted motor.
Series	Type	Encoder Type
WA: Battery-less Absolute	200: Servo motor 200W	24:24mm 16:16mm 8: 8mm 4: 4mm
Lead	Stroke	Applicable Controllers
24:24mm 16:16mm 8: 8mm 4: 4mm	50:50mm 300:300mm (50mm increments)	T2:SCON MSCON SSEL XSEL-P/Q XSEL-RA/SA
Cable Length	Options	
N : None P : 1m S : 3m M : 5m X <input type="checkbox"/> : Specified Length R <input type="checkbox"/> : Robot Cable	Refer to Options table below.	

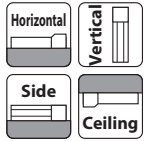

\* Depending on the model, there may be some limitations to using the vertical, side, and ceiling mount positions. Please refer to the Selection Notes on P.138 for more information.



**POINT Selection Notes**

- Both the horizontal and vertical payloads assume operation at an acceleration of 0.3G.
- When the acceleration is increased, the payload will be reduced. Please refer to "Table of Payload by Acceleration" on P.139 for more details.
- Estimated allowable duty varies depending on operating conditions (payload, acceleration/deceleration, etc.). Please refer to P. 149 for more information.
- The value of the horizontal payload assumes that there is an external guide. Please be aware that the anti-rotation stopper can be damaged when an external force is applied to the rod from any direction other than the moving direction.

## Actuator Specifications

### Lead and Payload

Model Number	Motor wattage (W)	Lead (mm)	Max. payload		Rated thrust (N)	Stroke (mm)
			Horizontal (kg)	Vertical (kg)		
RCS4-RA7R-WA-200-24-①-T2-②-③	200	24	20	6	142	50~300 (50mm increments)
RCS4-RA7R-WA-200-16-①-T2-②-③		16	45	12	214	
RCS4-RA7R-WA-200-8-①-T2-②-③		8	60	25	427	
RCS4-RA7R-WA-200-4-①-T2-②-③		4	80	35	855	

Legend: ① Stroke ② Cable Length ③ Option

### Stroke and Max Speed (Unit: mm/s)

Lead	Stroke	50~300
		(50mm increments)
24		1200
16		800
8		400
4		200

### ① Stroke

① Stroke (mm)	RCS4-RA7R	① Stroke (mm)	RCS4-RA7R
50	○	200	○
100	○	250	○
150	○	300	○

### ② Cable Length

Type	Cable Code
Standard	P(1m)
	S(3m)
	M(5m)
Specified length (Standard cable)	X06(6m) ~ X10(10m)
	X11(11m) ~ X15(15m)
	X16(16m) ~ X20(20m)
Robot cable	R01(1m) ~ R03(3m)
	R04(4m) ~ R05(5m)
	R06(6m) ~ R10(10m)
	R11(11m) ~ R15(15m)
	R16(16m) ~ R20(20m)

### ③ Options

Name	Option Code	Reference Page
Brake	B	See P.131
Cable exit direction (Top)	CJT	See P.131
Cable exit direction (Bottom)	CJB	See P.131
Cable exit direction (Outside)	CJO	See P.131
Flange	FL	See P.132
Foot bracket	FT	See P.133
Motor side-mounted to left (standard)	ML	See P.135
Motor side-mounted to right	MR	See P.135
Tip adapter (Internal thread)	NFA	See P.135
Non-motor end specification	NM	See P.136
T-slot nut bar specification	NTB	See P.136

### Actuator Specifications

Item	Description
Drive system	Ball screw φ12mm, rolled C10
Positioning repeatability	±0.01mm
Lost motion	0.1 mm or less
Rod	φ30mm Material: Aluminum with hard alumite treatment
Allowable static torque on rod tip	2.5N·m
Max. angular displacement on rod tip (*1)	±0.8 deg.
Ambient operating temp. & humidity	0~40°C, 85% RH or less (Non-condensing)

(\*1) This is the displacement angle of the rod tip (initial reference value) when the rod tip is fully retracted and the allowable static torque is applied at the rod tip.

\* Be sure to confirm with the "Selection Notes (P.138)" when selecting options.





\*1 When the rod is returning to its home position, please be careful of interference from surrounding objects, as it will travel until it reaches the M.E.  
M.E: Mechanical end S.E: Stroke end  
\*2 The direction of width across flat varies depending on the product. Those flats cannot be used for vertical or horizontal reference plane.

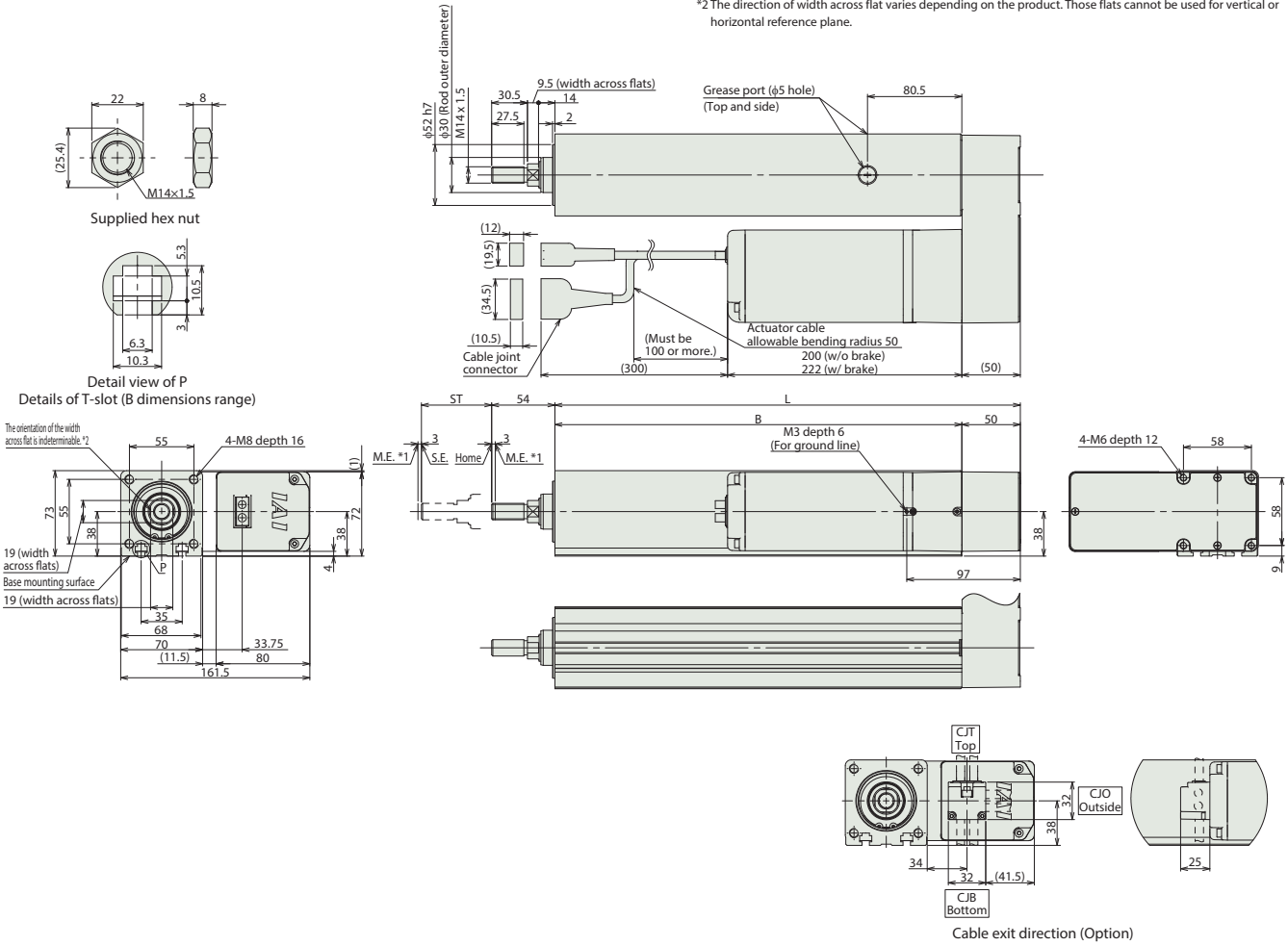

■ Dimensions and Mass by Stroke

Stroke	50	100	150	200	250	300	
L	247.5	297.5	347.5	397.5	447.5	497.5	
B	197.5	247.5	297.5	347.5	397.5	447.5	
Mass (kg)	W/o brake	5.4	6.0	6.5	7.1	7.7	8.3
	W/ brake	5.9	6.5	7.0	7.6	8.2	8.8

Applicable Controllers

The RCS4 series actuators can be operated by the controllers indicated below. Please select the type depending on your intended use.

Name	External view	Max. number of connectable axes	Input power	Control method				Maximum number of positioning points	Reference page	
				Positioner	Pulse train	Program	Network * Option			
SCON-CB/CGB		1	Single phase 100V/200VAC	●	●	—	DeviceNet CC-Link CC-Link IE CompoNet MECHATROLINK EtherCAT EtherNet/IP EtherCAT	512 (768 for network spec.)	Please contact IAI for more information.	
SCON-LC/LCG		1		—	—	●		512 (768 for network spec.)		
SCON-CAL/CGAL		1		●	—	—		512 (768 for network spec.)		
MSCON-C		6		This model is network-compatible only.				256		
SSEL-CS		2		●	—	●		20000		
XSEL-P/Q/RA/SA		8	Single phase 200VAC Three-phase 200VAC	—	—	●	55000 (Depending on the type)			

Note: The type of compatible networks will vary depending on the controller. Please refer to the reference page for more information.

Foreword  
Slider Type  
Wide Slider Type  
Rod Type  
Radial Cylinder  
Wide Radial Cylinder  
Table Type  
Cleanroom Slider  
Cleanroom Wide Slider  
Options  
Reference Data  
Controller

# RCS4-RA8R

Battery-less Absolute

Motor Unit Type

Side-mounted Motor

Body Width 90 mm\*

200v AC Servo Motor

Model Specification Items	<b>RCS4</b> — <b>RA8R</b> — <b>WA</b> — <b>400</b> — [ ] — [ ] — [ ] — <b>T2</b> — [ ] — [ ]	* Body width does not include the width of the side-mounted motor.						
Series	Type	Encoder Type	Motor Type	Lead	Stroke	Applicable Controllers	Cable Length	Options
WA: Battery-less Absolute	400: Servo motor 400W	20:20mm 10:10mm 5: 5mm	50:50mm 300:300mm (50mm increments)	T2:SCON SSEL XSEL-P/Q XSEL-RA/SA	N : None P : 1m S : 3m M : 5m	X [ ] : Specified Length R [ ] : Robot Cable	Refer to Options table below.	

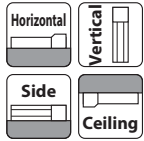

\* Depending on the model, there may be some limitations to using the vertical, side, and ceiling mount positions. Please refer to the Selection Notes on P.138 for more information.

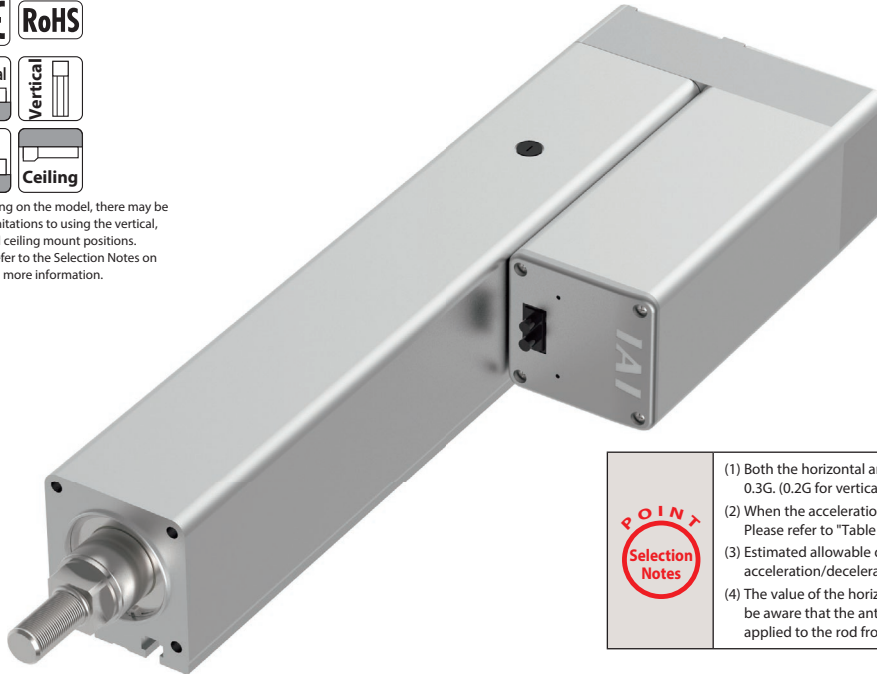

- POINT Selection Notes**
- Both the horizontal and vertical payloads assume operation at an acceleration of 0.3G. (0.2G for vertical lead 5).
  - When the acceleration is increased, the payload will be reduced. Please refer to "Table of Payload by Acceleration" on P.139 for more details.
  - Estimated allowable duty varies depending on operating conditions (payload, acceleration/deceleration, etc.). Please refer to P. 149 for more information.
  - The value of the horizontal payload assumes that there is an external guide. Please be aware that the anti-rotation stopper can be damaged when an external force is applied to the rod from any direction other than the moving direction.

## Actuator Specifications

### Lead and Payload

Model Number	Motor wattage (W)	Lead (mm)	Max. payload		Rated thrust (N)	Stroke (mm)
			Horizontal (kg)	Vertical (kg)		
RCS4-RA8R-WA-400-20-①-T2-②-③	400	20	60	20	339	50~300 (50mm increments)
RCS4-RA8R-WA-400-10-①-T2-②-③		10	80	40	678	
RCS4-RA8R-WA-400-5-①-T2-②-③		5	100	72	1357	

Legend: ① Stroke ② Cable Length ③ Option

### Stroke and Max Speed (Unit: mm/s)

Lead	Stroke	50~300 (50mm increments)
	20	1000
10	500	
5	250	

### ① Stroke

① Stroke (mm)	RCS4-RA8R	① Stroke (mm)	RCS4-RA8R
50	○	200	○
100	○	250	○
150	○	300	○

### ② Cable Length

Type	Cable Code
Standard	P(1m)
	S(3m)
	M(5m)
Specified length (Standard cable)	X06(6m) ~ X10(10m)
	X11(11m) ~ X15(15m)
	X16(16m) ~ X20(20m)
Robot cable	R01(1m) ~ R03(3m)
	R04(4m) ~ R05(5m)
	R06(6m) ~ R10(10m)
	R11(11m) ~ R15(15m)
	R16(16m) ~ R20(20m)
	R16(16m) ~ R20(20m)

### ③ Options

Name	Option Code	Reference Page
Brake	<b>B</b>	See P.131
Cable exit direction (Top)	<b>CJT</b>	See P.131
Cable exit direction (Bottom)	<b>CJB</b>	See P.131
Cable exit direction (Outside)	<b>CJO</b>	See P.131
Flange	<b>FL</b>	See P.132
Foot bracket	<b>FT</b>	See P.133
Motor side-mounted to left (standard)	<b>ML</b>	See P.135
Motor side-mounted to right	<b>MR</b>	See P.135
Tip adapter (Internal thread)	<b>NFA</b>	See P.135
Non-motor end specification	<b>NM</b>	See P.136
T-slot nut bar specification	<b>NTB</b>	See P.136

### Actuator Specifications

Item	Description
Drive system	Ball screw φ16mm, rolled C10
Positioning repeatability	±0.01mm
Lost motion	0.1 mm or less
Rod	φ40mm Material: Aluminum with hard alumite treatment
Allowable static torque on rod tip	5.0N·m
Max. angular displacement on rod tip (*1)	±0.8 deg.
Ambient operating temp. & humidity	0~40°C, 85% RH or less (Non-condensing)

(\*1) This is the displacement angle of the rod tip (initial reference value) when the rod tip is fully retracted and the allowable static torque is applied at the rod tip.

\* Be sure to confirm with the "Selection Notes (P.138)" when selecting options.



\*1 When the rod is returning to its home position, please be careful of interference from surrounding objects, as it will travel until it reaches the M.E.  
M.E: Mechanical end S.E: Stroke end  
\*2 The direction of width across flat varies depending on the product. Those flats cannot be used for vertical or horizontal reference plane.

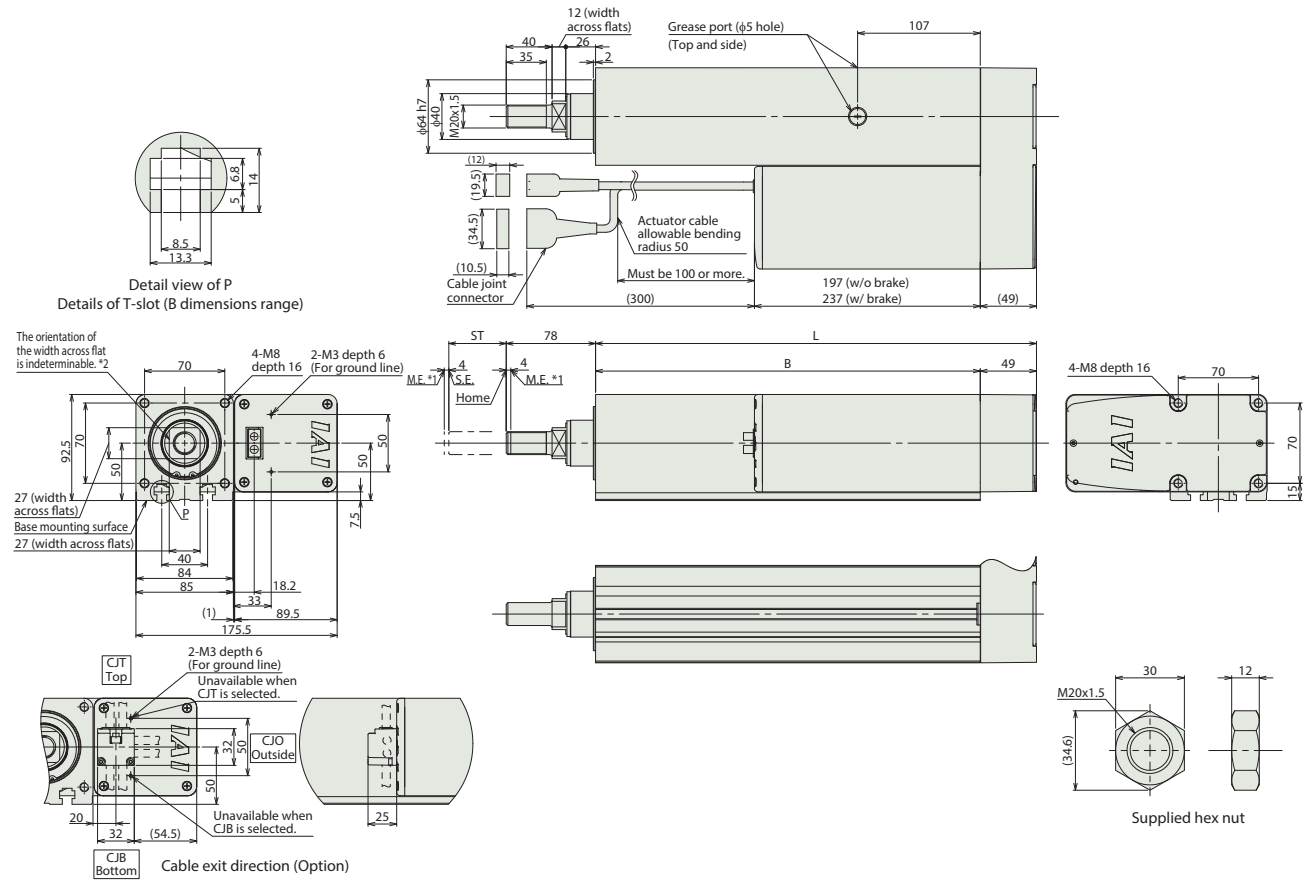

■ Dimensions and Mass by Stroke

Stroke	50	100	150	200	250	300
L	284.5	334.5	384.5	434.5	484.5	534.5
B	235.5	285.5	335.5	385.5	435.5	485.5
Mass (kg)						
W/o brake	9.6	10.4	11.2	12.1	12.9	13.8
W/ brake	10.2	11.0	11.8	12.7	13.5	14.4

Applicable Controllers

The RCS4 series actuators can be operated by the controllers indicated below. Please select the type depending on your intended use.

Name	External view	Max. number of connectable axes	Input power	Control method				Maximum number of positioning points	Reference page
				Positioner	Pulse train	Program	Network * Option		
SCON-CB/CGB		1	Single phase 200VAC	●	●	-	<b>DeviceNet</b> <b>CC-Link</b> <b>PROFINET</b> <b>CompoNet</b> <b>MECHATROLINK</b> <b>EtherCAT</b> <b>EtherNet/IP</b>	512 (768 for network spec.)	Please contact IAI for more information.
SCON-LC/LCG		1		-	-	●		512 (768 for network spec.)	
SSEL-CS		2	Single phase 100V/200VAC	●	-	●	20000		
XSEL-P/Q/RA/SA		8	Single phase 200VAC Three-phase 200VAC	-	-	●	55000 (Depending on the type)		

Note: The type of compatible networks will vary depending on the controller. Please refer to the reference page for more information.

Foreword  
Slider Type  
Wide Slider Type  
Rod Type  
Radial Cylinder  
Wide Radial Cylinder  
Table Type  
Cleanroom Slider  
Cleanroom Wide Slider  
Options  
Reference Data  
Controller

# RCS4-RAA4C

Battery-less Absolute

Motor Unit Type

Coupled Motor

Body Width  
40 mm

200v AC Servo Motor

Model Specification Items	<b>RCS4</b> — Series	<b>RRA4C</b> — Type	<b>WA</b> — Encoder Type	<b>60</b> — Motor Type	Lead	Stroke	<b>T2</b> — Applicable Controllers	Cable Length	Options
			WA: Battery-less Absolute	60: Servo motor 60W	16: 16mm 10: 10mm 5: 5mm 2.5: 2.5mm	60: 60mm 410: 410mm (50mm increments)	T2: SCON MSCON SSEL XSEL-P/Q XSEL-RA/SA	N: None P: 1m S: 3m M: 5m X□□: Specified Length R□□: Robot Cable	Refer to Options table below.



\* Depending on the model, there may be some limitations to using the vertical, side, and ceiling mount positions. Please refer to the Selection Notes on P.138 for more information.



**POINT Selection Notes**

- (1) Both the horizontal and vertical payloads assume operation at an acceleration of 0.3G.
- (2) When the acceleration is increased, the payload will be reduced. Please refer to "Table of Payload by Acceleration" on P.139 for more details.
- (3) Estimated allowable duty varies depending on operating conditions (payload, acceleration/deceleration, etc.). Please refer to P. 149 for more information.
- (4) The radial cylinder is equipped with a built-in guide. Please refer to the graphs shown on P.145 and after for the allowable load mass.

## Actuator Specifications

### Lead and Payload

Model Number	Motor wattage (W)	Lead (mm)	Max. payload		Rated thrust (N)	Stroke (mm)
			Horizontal (kg)	Vertical (kg)		
RCS4-RAA4C-WA-60-16-①-T2-②-③	60	16	8	2	53	60~410 (50mm increments)
RCS4-RAA4C-WA-60-10-①-T2-②-③		10	18	4	85	
RCS4-RAA4C-WA-60-5-①-T2-②-③		5	30	6	170	
RCS4-RAA4C-WA-60-2.5-①-T2-②-③		2.5	40	10	340	

Legend: ① Stroke ② Cable Length ③ Option

### Stroke and Max Speed (Unit: mm/s)

Lead	Stroke	60~410 (50mm increments)
16		960
10		600
5		300
2.5		150

### ① Stroke

① Stroke (mm)	RCS4-RAA4C	① Stroke (mm)	RCS4-RAA4C
60	○	260	○
110	○	310	○
160	○	360	○
210	○	410	○

### ② Cable Length

Type	Cable Code
Standard	P(1m)
	S(3m)
	M(5m)
Specified length (Standard cable)	X06(6m) ~ X10(10m)
	X11(11m) ~ X15(15m)
	X16(16m) ~ X20(20m)
Robot cable	R01(1m) ~ R03(3m)
	R04(4m) ~ R05(5m)
	R06(6m) ~ R10(10m)
	R11(11m) ~ R15(15m)
	R16(16m) ~ R20(20m)

### ③ Options

Name	Option Code	Reference Page
Brake	<b>B</b>	See P.131
Cable exit direction (Top)	<b>CJT</b>	See P.131
Cable exit direction (Right)	<b>CJR</b>	See P.131
Cable exit direction (Left)	<b>CJL</b>	See P.131
Cable exit direction (Bottom)	<b>CJB</b>	See P.131
Flange	<b>FL</b>	See P.132
Tip adapter (Flange)	<b>FFA</b>	See P.131
Tip adapter (Keyway)	<b>KFA</b>	See P.134
Tip adapter (Internal thread)	<b>NFA</b>	See P.135
Non-motor end specification	<b>NM</b>	See P.136

### Actuator Specifications

Item	Description
Drive system	Ball screw φ8mm, rolled C10
Positioning repeatability	±0.01mm
Lost motion	0.1 mm or less
Rod	φ20mm Material: Aluminum with hard alumite treatment
Rod non-rotation precision	0 degrees
Allowable load and torque on rod tip	Please see P. 60
Rod tip overhang distance	100mm
Ambient operating temp. & humidity	0~40°C, 85% RH or less (Non-condensing)



- \*1 The two mounting holes (H) on the rod side of the top surface cannot be used.  
(Note) When the rod is returning to its home position, please be mindful of possible interference from surrounding objects, as it will travel until it reaches the M.E.
- \*2 The direction of width across flats varies depending on the product. Those flats cannot be used for vertical or horizontal reference plane.

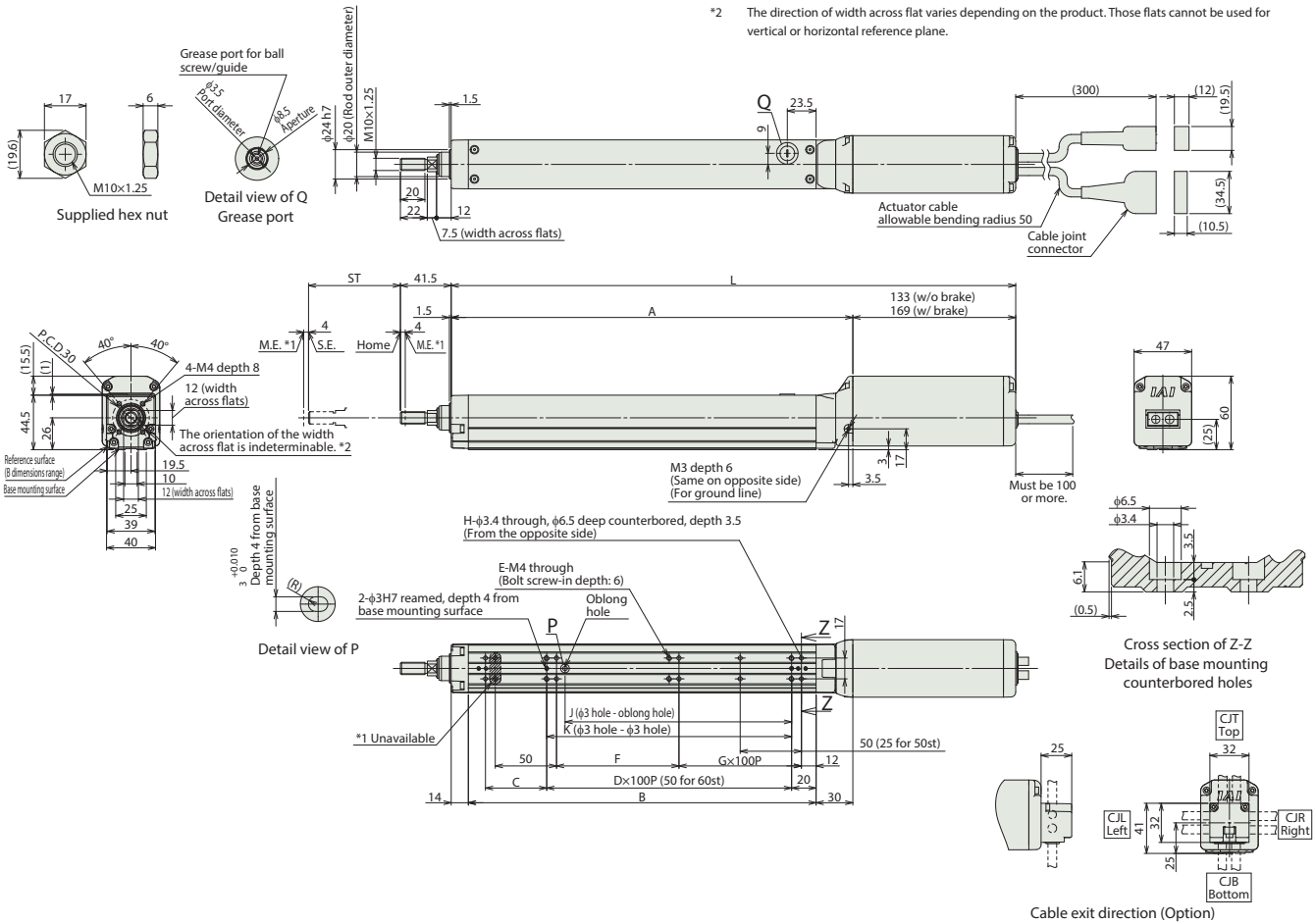

■ Dimensions and Mass by Stroke

Stroke	Stroke								
	60	110	160	210	260	310	360	410	
L	W/o brake	311	361	411	461	511	561	611	661
	W/ brake	347	397	447	497	547	597	647	697
A	178	228	278	328	378	428	478	528	
B	134	184	234	284	334	384	434	484	
C	50	50	100	50	100	50	100	50	
D	0	1	1	2	2	3	3	4	
E	6	6	6	8	8	10	10	12	
F	50	100	50	100	50	100	50	100	
G	0	0	1	1	2	2	3	3	
H *2	6	6	8	8	10	10	12	12	
J	35	85	85	185	185	285	285	385	
K	50	100	100	200	200	300	300	400	
Allowable static load on rod tip (N)		63.4	50.7	42.1	36.0	31.3	27.6	24.6	22.2
Allowable dynamic load on rod tip (5000km life) (N)	Load offset 0mm	28.9	22.2	17.9	14.8	12.6	10.8	9.4	8.2
	Load offset 100mm	17.9	15.5	13.4	11.6	10.2	9.0	8.0	7.1
Allowable static torque on rod tip (N-m)		6.4	5.1	4.3	3.7	3.2	2.9	2.6	2.3
Allowable dynamic torque on rod tip (N-m)		1.7	1.5	1.3	1.1	1.0	0.9	0.7	0.7
Mass (kg)	W/o brake	1.3	1.3	1.4	1.5	1.6	1.7	1.8	1.9
	W/ brake	1.6	1.6	1.7	1.8	1.9	2.0	2.1	2.2

\*2 Does not include holes that are not available.

■ Rod Deflection of RCS4-RRR4C (Reference Values)

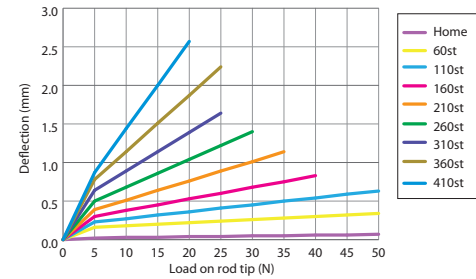

■ Applicable Controllers

The RCS4 series actuators can be operated by the controllers indicated below. Please select the type depending on your intended use.

Name	External view	Max. number of connectable axes	Input power	Control method				Maximum number of positioning points	Reference page	
				Positioner	Pulse train	Program	Network * Option			
SCON-CB/CGB		1	Single phase 100V/200VAC	●	●	—	DeviceNet CC-Link CC-Link IE CompoNet MECHATROLINK EtherCAT EtherNet/IP	512 (768 for network spec.)	Please contact IAI for more information.	
SCON-LC/LCG		1		—	—	●		512 (768 for network spec.)		
SCON-CAL/CGAL		1		—	—	—		512 (768 for network spec.)		
MSCON-C		6		This model is network-compatible only.				256		
SSEL-CS		2		●	—	●		20000		
XSEL-P/Q/RA/SA		8		Single phase 200VAC Three-phase 200VAC	—	—		●		55000 (Depending on the type)

Note:  
The type of compatible networks will vary depending on the controller. Please refer to the reference page for more information.

Foreword  
Slider Type  
Wide Slider Type  
Rod Type  
Radial Cylinder  
Wide Radial Cylinder  
Table Type  
Cleanroom Slider  
Cleanroom Wide Slider  
Options  
Reference Data  
Controller

# RCS4-RRRA6C

Battery-less Absolute

Motor Unit Type

Coupled Motor

Body Width  
60 mm

200v AC Servo Motor

Model Specification Items	<b>RCS4</b> — Series	<b>RRRA6C</b> — Type	<b>WA</b> — Encoder Type	<b>100</b> — Motor Type	Lead	Stroke	<b>T2</b> — Applicable Controllers	Cable Length	Options
			WA: Battery-less Absolute	100: Servo motor 100W	20:20mm 12:12mm 6: 6mm 3: 3mm	65:65mm 415:415mm (50mm increments)	T2:SCON MSCON SSEL XSEL-P/Q XSEL-RA/SA	N : None P : 1m S : 3m M : 5m X□□ : Specified Length R□□ : Robot Cable	Refer to Options table below.

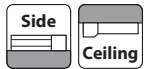

\* Depending on the model, there may be some limitations to using the vertical, side, and ceiling mount positions. Please refer to the Selection Notes on P.138 for more information.



**POINT Selection Notes**

- (1) Both the horizontal and vertical payloads assume operation at an acceleration of 0.3G.
- (2) When the acceleration is increased, the payload will be reduced. Please refer to "Table of Payload by Acceleration" on P.139 for more details.
- (3) Estimated allowable duty varies depending on operating conditions (payload, acceleration/deceleration, etc.). Please refer to P. 149 for more information.
- (4) The radial cylinder is equipped with a built-in guide. Please refer to the graphs shown on P.145 and after for the allowable load mass.

## Actuator Specifications

### Lead and Payload

Model Number	Motor wattage (W)	Lead (mm)	Max. payload		Rated thrust (N)	Stroke (mm)
			Horizontal (kg)	Vertical (kg)		
RCS4-RRRA6C-WA-100-20-①-T2-②-③	100	20	15	4	85	65~415 (50mm increments)
RCS4-RRRA6C-WA-100-12-①-T2-②-③		12	25	10	142	
RCS4-RRRA6C-WA-100-6-①-T2-②-③		6	50	20	283	
RCS4-RRRA6C-WA-100-3-①-T2-②-③		3	60	20	566	

Legend: ① Stroke ② Cable Length ③ Option

### Stroke and Max Speed (Unit: mm/s)

Lead	Stroke	65~415
		(50mm increments)
20		1200
12		720
6		360
3		180

### ① Stroke

① Stroke (mm)	RCS4-RRRA6C	① Stroke (mm)	RCS4-RRRA6C
65	○	265	○
115	○	315	○
165	○	365	○
215	○	415	○

### ② Cable Length

Type	Cable Code
Standard	P(1m)
	S(3m)
	M(5m)
Specified length (Standard cable)	X06(6m) ~ X10(10m)
	X11(11m) ~ X15(15m)
	X16(16m) ~ X20(20m)
Robot cable	R01(1m) ~ R03(3m)
	R04(4m) ~ R05(5m)
	R06(6m) ~ R10(10m)
	R11(11m) ~ R15(15m)
	R16(16m) ~ R20(20m)

### ③ Options

Name	Option Code	Reference Page
Brake	<b>B</b>	See P.131
Cable exit direction (Top)	<b>CJT</b>	See P.131
Cable exit direction (Right)	<b>CJR</b>	See P.131
Cable exit direction (Left)	<b>CJL</b>	See P.131
Cable exit direction (Bottom)	<b>CJB</b>	See P.131
Flange	<b>FL</b>	See P.132
Tip adapter (Flange)	<b>FFA</b>	See P.131
Tip adapter (Keyway)	<b>KFA</b>	See P.134
Tip adapter (Internal thread)	<b>NFA</b>	See P.135
Non-motor end specification	<b>NM</b>	See P.136

### Actuator Specifications

Item	Description
Drive system	Ball screw φ10mm, rolled C10
Positioning repeatability	±0.01mm
Lost motion	0.1 mm or less
Rod	φ25mm Material: Aluminum with hard alumite treatment
Rod non-rotation precision	0 degrees
Allowable load and torque on rod tip	Please see P. 62
Rod tip overhang distance	100mm
Ambient operating temp. & humidity	0~40°C, 85% RH or less (Non-condensing)



\*1 When the rod is returning to its home position, please be careful of interference from surrounding objects, as it will travel until it reaches the M.E.  
M.E: Mechanical end S.E: Stroke end  
\*2 The direction of width across flat varies depending on the product. Those flats cannot be used for vertical horizontal reference plane.

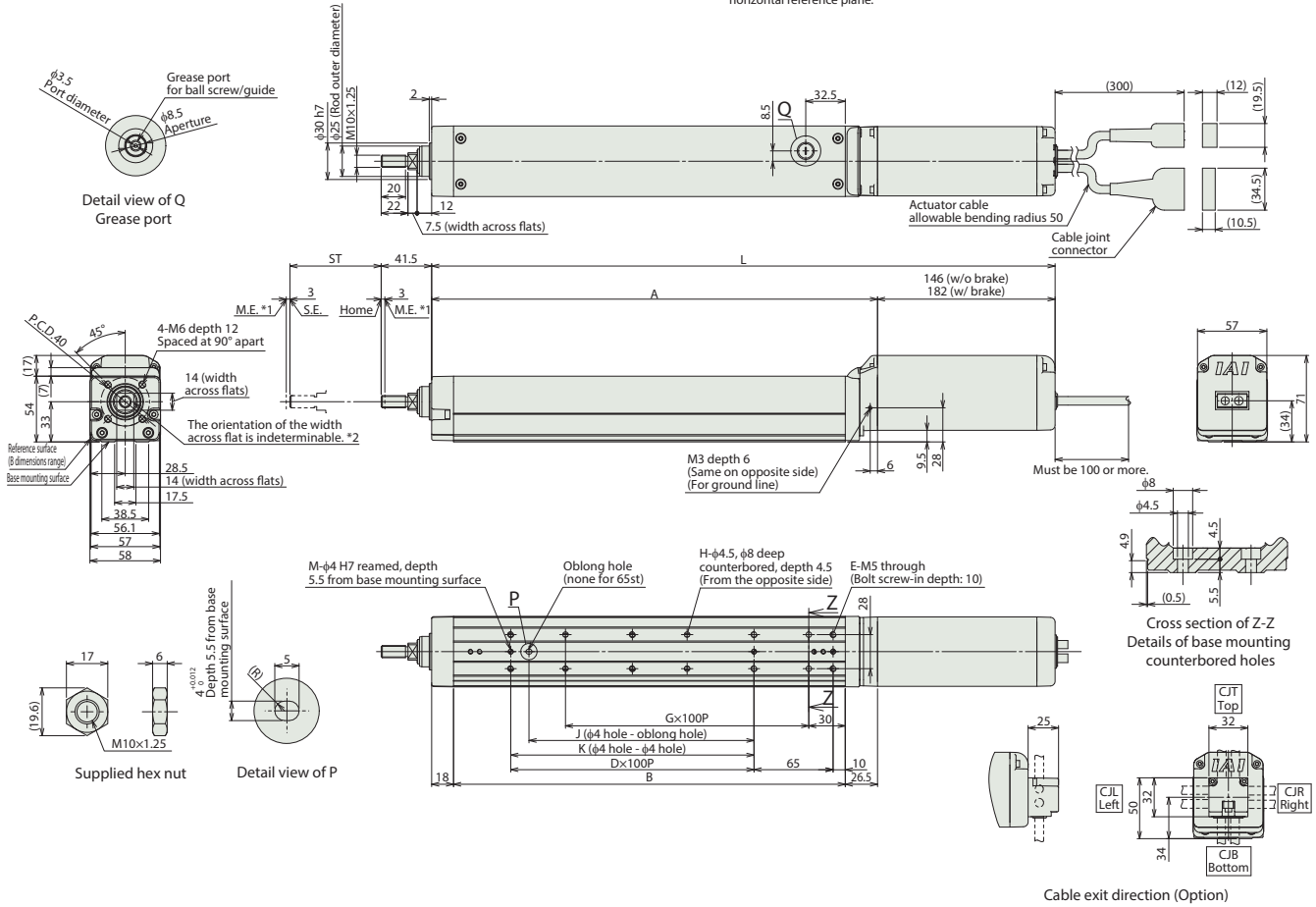

**Dimensions and Mass by Stroke**

Stroke	L								
	W/o brake	362.5	412.5	462.5	512.5	562.5	612.5	662.5	712.5
A	216.5	266.5	316.5	366.5	416.5	466.5	516.5	566.5	566.5
B	172	222	272	322	372	422	472	522	522
D	0	1	1	2	2	3	3	4	4
E	4	6	6	8	8	10	10	12	12
G	1	1	2	2	3	3	4	4	4
H	4	4	6	6	8	8	10	10	10
J	0	85	85	185	185	285	285	385	385
K	0	100	100	200	200	300	300	400	400
M	2	3	3	3	3	3	3	3	3
Allowable static load on rod tip (N)	144	117	99	85.4	75	66.7	59.9	54.3	54.3
Allowable dynamic load on rod tip (5000km life) (N)	Load offset 0mm	58.1	46.4	38.3	32.4	27.9	24.4	21.5	19.2
	Load offset 100mm	38.8	34.0	29.7	26.2	23.2	20.8	18.7	16.8
Allowable static torque on rod tip (N-m)	14.5	11.8	10.0	8.7	7.6	6.8	6.2	5.6	5.6
Allowable dynamic torque on rod tip (N-m)	3.8	3.3	2.9	2.6	2.3	2.0	1.8	1.6	1.6
Mass (kg)	W/o brake	2.1	2.4	2.6	2.8	3.1	3.3	3.5	3.7
	W/brake	2.4	2.7	2.9	3.1	3.4	3.6	3.8	4.0

**Rod Deflection of RCS4-RRAC6 (Reference Values)**

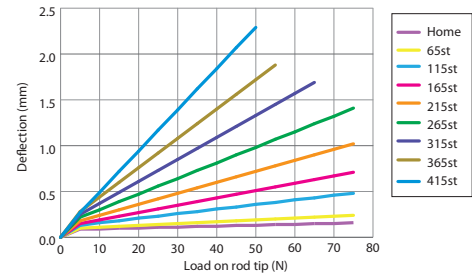

**Applicable Controllers**

The RCS4 series actuators can be operated by the controllers indicated below. Please select the type depending on your intended use.

Name	External view	Max. number of connectable axes	Input power	Control method				Maximum number of positioning points	Reference page	
				Positioner	Pulse train	Program	Network * Option			
SCON-CB/CGB		1	Single phase 100V/200VAC	●	●	—	DeviceNet CC-Link CC-Link IE CompoNet MECHATROLINK EtherCAT EtherNet/IP	512 (768 for network spec.)	Please contact IAI for more information.	
SCON-LC/LCG		1		—	—	●		512 (768 for network spec.)		
SCON-CAL/CGAL		1		●	—	—		512 (768 for network spec.)		
MSCON-C		6		This model is network-compatible only.				256		
SSEL-CS		2		●	—	●		20000		
XSEL-P/Q/RA/SA		8	Single phase 200VAC Three-phase 200VAC	—	—	●	55000 (Depending on the type)			

Note: The type of compatible networks will vary depending on the controller. Please refer to the reference page for more information.

# RCS4-RAA7C

Battery-less Absolute

Motor Unit Type

Coupled Motor

Body Width  
70 mm

200v AC Servo Motor

Model Specification Items	<b>RCS4</b> — Series	<b>RRA7C</b> — Type	<b>WA</b> — Encoder Type	<b>200</b> — Motor Type	Lead	Stroke	<b>T2</b> — Applicable Controllers	Cable Length	Options
			WA: Battery-less Absolute	200: Servo motor 200W	24:24mm 16:16mm 8: 8mm 4: 4mm	70:70mm 520:520mm (50mm increments)	T2:SCON MSCON SSEL XSEL-P/Q XSEL-RA/SA	N : None P : 1m S : 3m M : 5m X□□ : Specified Length R□□ : Robot Cable	Refer to Options table below.

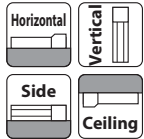

\* Depending on the model, there may be some limitations to using the vertical, side, and ceiling mount positions. Please refer to the Selection Notes on P.138 for more information.

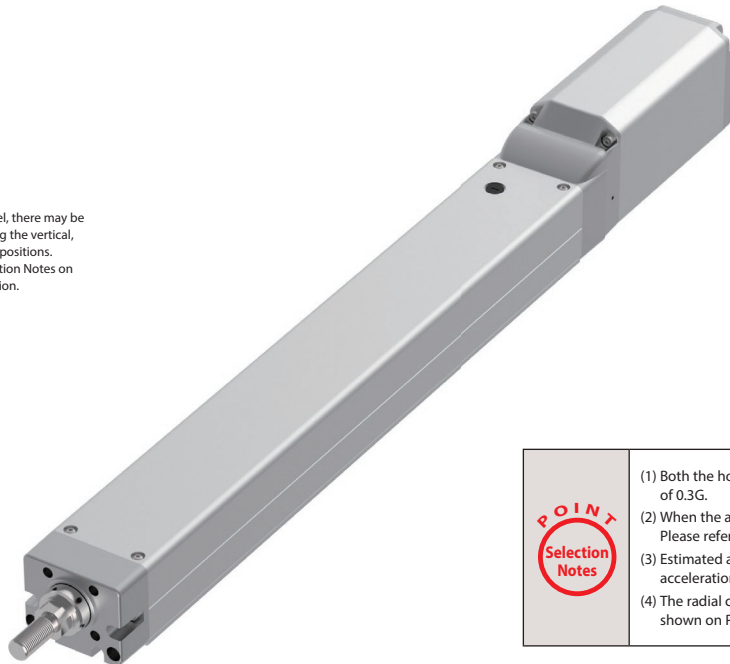

**POINT Selection Notes**

- (1) Both the horizontal and vertical payloads assume operation at an acceleration of 0.3G.
- (2) When the acceleration is increased, the payload will be reduced. Please refer to "Table of Payload by Acceleration" on P.139 for more details.
- (3) Estimated allowable duty varies depending on operating conditions (payload, acceleration/deceleration, etc.). Please refer to P. 149 for more information.
- (4) The radial cylinder is equipped with a built-in guide. Please refer to the graphs shown on P.145 and after for the allowable load mass.

## Actuator Specifications

### Lead and Payload

Model Number	Motor wattage (W)	Lead (mm)	Max. payload		Rated thrust (N)	Stroke (mm)
			Horizontal (kg)	Vertical (kg)		
RCS4-RAA7C-WA-200-24-①-T2-②-③	200	24	20	6	142	70~520 (50mm increments)
RCS4-RAA7C-WA-200-16-①-T2-②-③		16	45	12	214	
RCS4-RAA7C-WA-200-8-①-T2-②-③		8	60	25	427	
RCS4-RAA7C-WA-200-4-①-T2-②-③		4	80	35	855	

Legend: ① Stroke ② Cable Length ③ Option

### Stroke and Max Speed (Unit: mm/s)

Lead	Stroke (50mm increments)	70~520
		Max Speed
24	1440	
16	960	
8	480	
4	240	

### ① Stroke

① Stroke (mm)	RCS4-RAA7C	① Stroke (mm)	RCS4-RAA7C
70	○	320	○
120	○	370	○
170	○	420	○
220	○	470	○
270	○	520	○

### ② Cable Length

Type	Cable Code
Standard	P(1m)
	S(3m)
	M(5m)
Specified length (Standard cable)	X06(6m) ~ X10(10m)
	X11(11m) ~ X15(15m)
	X16(16m) ~ X20(20m)
Robot cable	R01(1m) ~ R03(3m)
	R04(4m) ~ R05(5m)
	R06(6m) ~ R10(10m)
	R11(11m) ~ R15(15m)
	R16(16m) ~ R20(20m)

### ③ Options

Name	Option Code	Reference Page
Brake	<b>B</b>	See P.131
Cable exit direction (Top)	<b>CJT</b>	See P.131
Cable exit direction (Right)	<b>CJR</b>	See P.131
Cable exit direction (Left)	<b>CJL</b>	See P.131
Cable exit direction (Bottom)	<b>CJB</b>	See P.131
Flange	<b>FL</b>	See P.132
Tip adapter (Flange)	<b>FFA</b>	See P.131
Tip adapter (Keyway)	<b>KFA</b>	See P.134
Tip adapter (Internal thread)	<b>NFA</b>	See P.135
Non-motor end specification	<b>NM</b>	See P.136

### Actuator Specifications

Item	Description
Drive system	Ball screw φ12mm, rolled C10
Positioning repeatability	±0.01mm
Lost motion	0.1 mm or less
Rod	φ30mm Material: Aluminum with hard alumite treatment
Rod non-rotation precision	0 degrees
Allowable load and torque on rod tip	Please see P. 64
Rod tip overhang distance	150mm
Ambient operating temp. & humidity	0~40°C, 85% RH or less (Non-condensing)



Dimensions

CAD drawings can be downloaded from our website.  
www.intelligentactuator.com



\*1 When the rod is returning to its home position, please be careful of interference from surrounding objects, as it will travel until it reaches the M.E.  
M.E: Mechanical end S.E: Stroke end  
\*2 The direction of width across flat varies depending on the product. Those flats cannot be used for vertical horizontal reference plane.

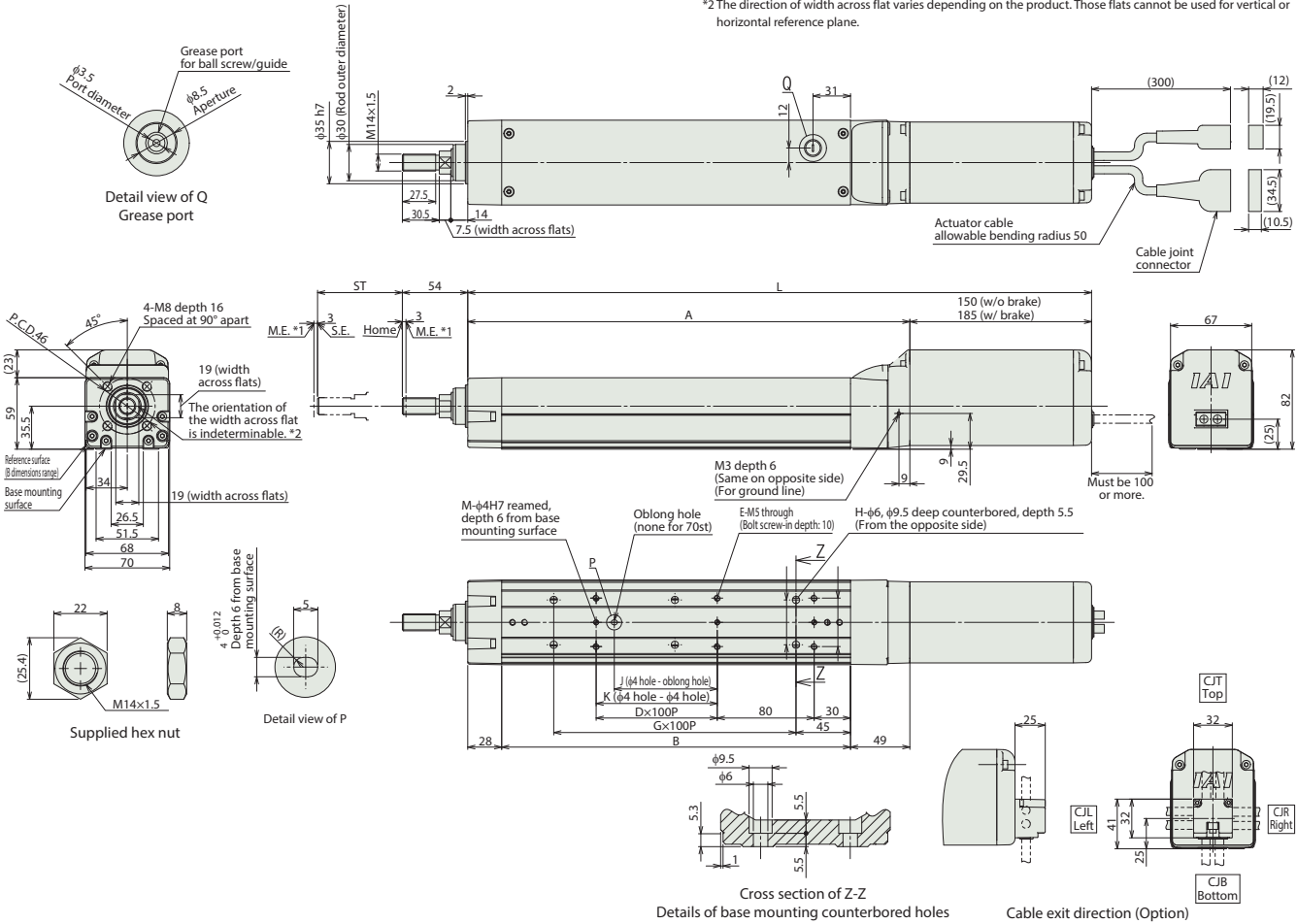

Dimensions and Mass by Stroke

Stroke	L	W/o brake	Stroke								
			70	120	170	220	270	320	370	420	470
A	W/o brake	415	465	515	565	615	665	715	765	815	865
		450	500	550	600	650	700	750	800	850	900
B		265	315	365	415	465	515	565	615	665	715
D		188	238	288	338	388	438	488	538	588	638
E		0	1	1	2	2	3	3	4	4	5
G		4	6	6	8	8	10	10	12	12	14
H		1	1	2	2	3	3	4	4	5	5
J		4	4	6	6	8	8	10	10	12	12
K		0	85	85	185	185	285	285	385	385	485
M		0	0	100	200	200	300	300	400	400	500
M		2	2	3	3	3	3	3	3	3	3
Allowable static load on rod tip (N)		175	147	126	111	98.6	88.7	80.6	73.8	68	63
Allowable dynamic load on rod tip (5000km life) (N)		75.7	62.6	53.1	46.0	40.5	36.1	32.5	29.4	26.9	24.7
Allowable static torque on rod tip (N·m)		49.8	45.1	40.5	36.5	33.1	30.2	27.7	25.5	23.6	21.9
Allowable dynamic torque on rod tip (N·m)		17.6	14.7	12.7	11.2	9.9	9.0	8.2	7.5	6.94	6.45
Allowable dynamic torque on rod tip (N·m)		5.0	4.5	4.0	3.6	3.3	3.0	2.8	2.5	2.32	2.16
Mass (kg)	W/o brake	3.7	4.0	4.2	4.5	4.8	5.0	5.3	5.6	5.8	6.1
	W/ brake	4.2	4.5	4.7	5.0	5.3	5.5	5.8	6.1	6.3	6.6

Rod Deflection of RCS4-RR47C (Reference Values)

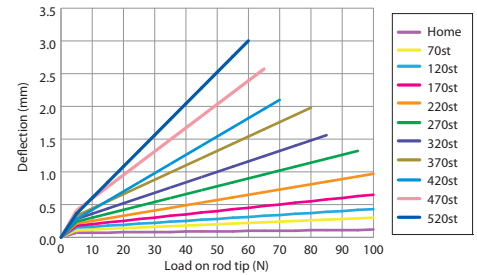

Applicable Controllers

The RCS4 series actuators can be operated by the controllers indicated below. Please select the type depending on your intended use.

Name	External view	Max. number of connectable axes	Input power	Control method				Maximum number of positioning points	Reference page	
				Positioner	Pulse train	Program	Network * Option			
SCON-CB/CGB		1	Single phase 100V/200VAC	●	●	—	DeviceNet CC-Link CC-Link IE CompoNet MECHATROLINK EtherCAT EtherNet/IP	512 (768 for network spec.)	Please contact IAI for more information.	
SCON-LC/LCG		1		—	—	●		512 (768 for network spec.)		
SCON-CAL/CGAL		1		—	—	—		512 (768 for network spec.)		
MSCON-C		6		This model is network-compatible only.				256		
SSEL-CS		2		●	—	●		20000		
XSEL-P/Q/RA/SA		8		Single phase 200VAC Three-phase 200VAC	—	—		●		55000 (Depending on the type)

# RCS4-RRR8C

Battery-less Absolute

Motor Unit Type

Coupled Motor

Body Width 90 mm

200v AC Servo Motor

Model Specification Items	<b>RCS4</b> — Series	<b>RRR8C</b> — Type	<b>WA</b> — Encoder Type	<b>400</b> — Motor Type	Lead	Stroke	<b>T2</b> — Applicable Controllers	Cable Length	Options
			WA: Battery-less Absolute	400: Servo motor 400W	30:30mm 20:20mm 10:10mm 5: 5mm	50:50mm 700:700mm (50mm increments)	T2:SCON SSEL XSEL-P/Q XSEL-RA/SA	N : None P : 1m S : 3m M : 5m X□□ : Specified Length R□□ : Robot Cable	Refer to Options table below.



\* Depending on the model, there may be some limitations to using the vertical, side, and ceiling mount positions. Please refer to the Selection Notes on P.138 for more information.

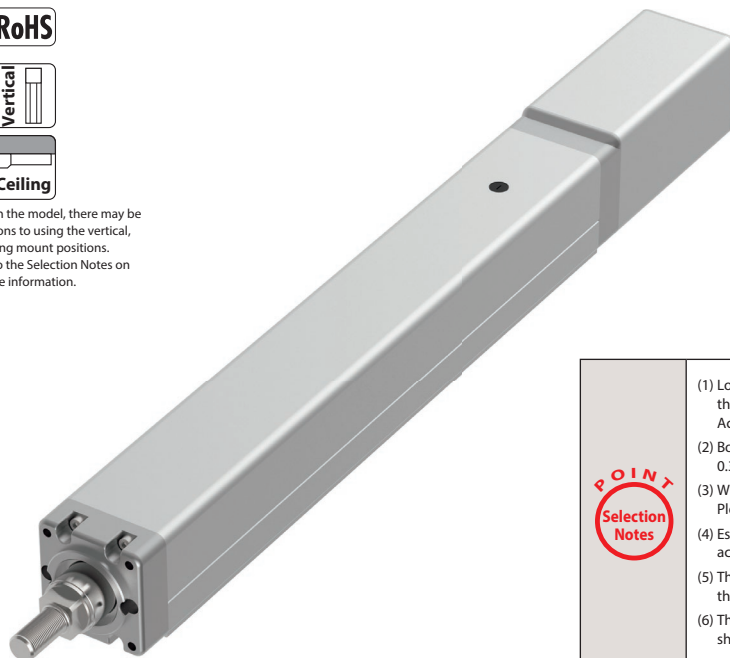

- (1) Longer strokes may cause the maximum speed to decrease due to resonance of the ball screw. Be sure to check the maximum speed of the desired stroke in the Actuator Specifications table, which can be found below.
- (2) Both the horizontal and vertical payloads assume operation at an acceleration of 0.3G. (0.2G for lead 5).
- (3) When the acceleration is increased, the payload will be reduced. Please refer to "Table of Payload by Acceleration" on P.139 for more details.
- (4) Estimated allowable duty varies depending on operating conditions (payload, acceleration/deceleration, etc.). Please refer to P. 149 for more information.
- (5) The value of the maximum payload assumes that there is an external guide and that the rod is not subjected to external force other than in the moving direction.
- (6) The radial cylinder is equipped with a built-in guide. Please refer to the graphs shown on P.145 and after for the allowable load mass.

## Actuator Specifications

### Lead and Payload

Model Number	Motor wattage (W)	Lead (mm)	Max. payload		Rated thrust (N)	Stroke (mm)
			Horizontal (kg)	Vertical (kg)		
RCS4-RRR8C-WA-400-30-①-T2-②-③	400	30	30	8	226	50~700 (50mm increments)
RCS4-RRR8C-WA-400-20-①-T2-②-③		20	60	20	339	
RCS4-RRR8C-WA-400-10-①-T2-②-③		10	80	40	678	
RCS4-RRR8C-WA-400-5-①-T2-②-③		5	100	72	1357	

Legend: ① Stroke ② Cable Length ③ Option

### Stroke and Max Speed

(Unit: mm/s)

Stroke / Lead	Stroke (mm)									
	50~250 (50mm increments)	300	350	400	450	500	550	600	650	700
30	1500	1500	1230	970	790	650	540	460	400	350
20	1100	1070	820	650	520	430	360	310	260	230
10	550	520	400	310	250	210	180	150	130	110
5	275	250	190	150	120	100	80	70	60	55

### ① Stroke

① Stroke (mm)	RCS4-RRR8C	① Stroke (mm)	RCS4-RRR8C
50	○	400	○
100	○	450	○
150	○	500	○
200	○	550	○
250	○	600	○
300	○	650	○
350	○	700	○

### ② Cable Length

Type	Cable Code
Standard	P(1m)
	S(3m)
	M(5m)
Specified length (Standard cable)	X06(6m) ~ X10(10m)
	X11(11m) ~ X15(15m)
	X16(16m) ~ X20(20m)
Robot cable	R01(1m) ~ R03(3m)
	R04(4m) ~ R05(5m)
	R06(6m) ~ R10(10m)
	R11(11m) ~ R15(15m)
	R16(16m) ~ R20(20m)

### ③ Options

Name	Option Code	Reference Page
Brake	<b>B</b>	See P.131
Cable exit direction (Top)	<b>CJT</b>	See P.131
Cable exit direction (Right)	<b>CJR</b>	See P.131
Cable exit direction (Left)	<b>CJL</b>	See P.131
Cable exit direction (Bottom)	<b>CJB</b>	See P.131
Flange	<b>FL</b>	See P.132
Tip adapter (Internal thread)	<b>NFA</b>	See P.135
Non-motor end specification	<b>NM</b>	See P.136

### Actuator Specifications

Item	Description
Drive system	Ball screw φ16mm, rolled C10
Positioning repeatability	±0.01mm
Lost motion	0.1 mm or less
Rod	φ40mm Material: Aluminum with hard alumite treatment
Rod non-rotation precision	0 degrees
Allowable load and torque on rod tip	Please see P. 66
Rod tip overhang distance	150mm
Ambient operating temp. & humidity	0~40°C, 85% RH or less (Non-condensing)

CAD drawings can be downloaded from our website.  
www.intelligentactuator.com



\*1 When the rod is returning to its home position, please be careful of interference from surrounding objects, as it will travel until it reaches the M.E.  
M.E: Mechanical end S.E: Stroke end  
\*2 The direction of width across flat varies depending on the product. Those flats cannot be used for vertical horizontal reference plane.

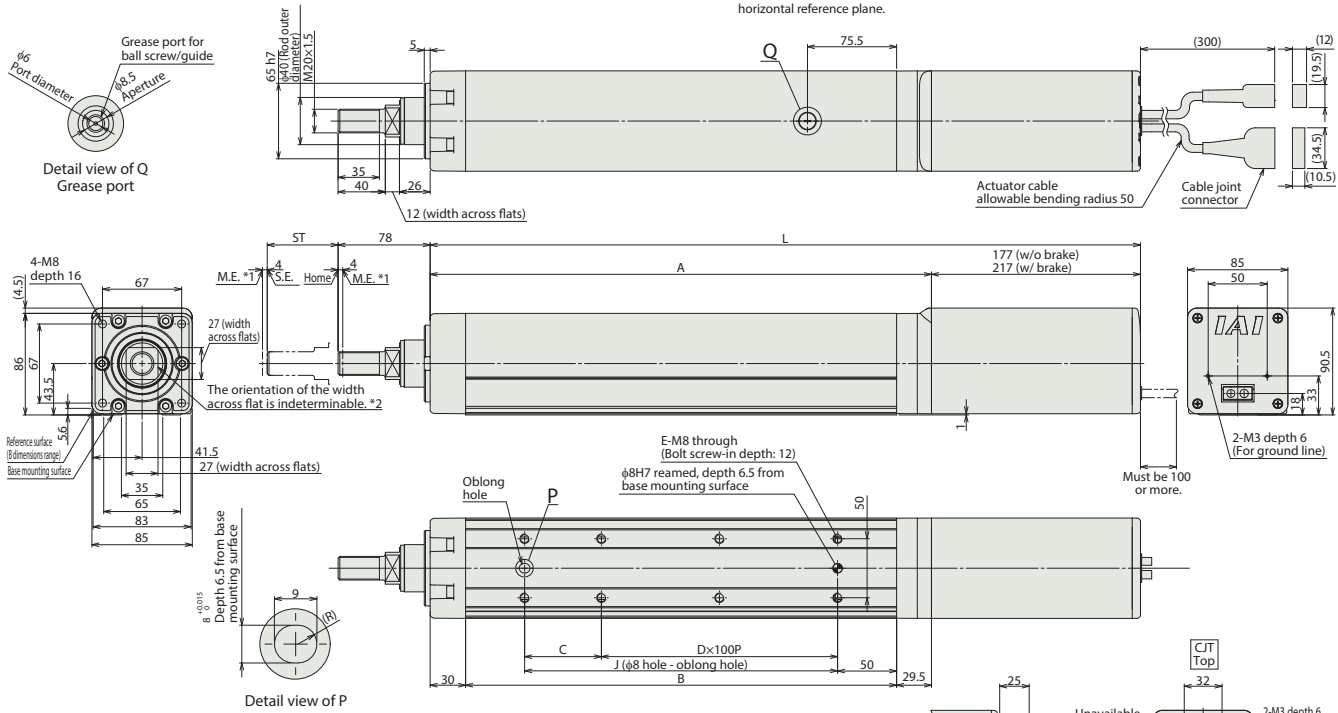

**Rod Deflection of RCS4-RR48C (Reference Values)**

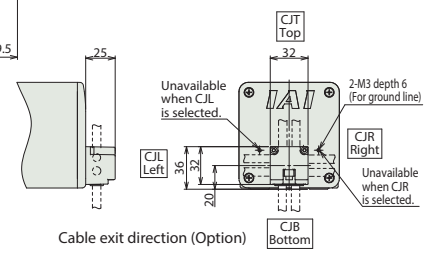
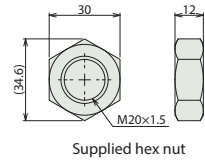
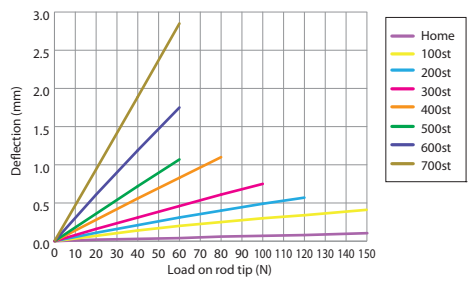

**Dimensions and Mass by Stroke**

Stroke	L	Stroke													
		50	100	150	200	250	300	350	400	450	500	550	600	650	700
L	W/o brake	451.5	501.5	551.5	601.5	651.5	701.5	751.5	801.5	851.5	901.5	951.5	1001.5	1051.5	1101.5
	W/ brake	491.5	541.5	591.5	641.5	691.5	741.5	791.5	841.5	891.5	941.5	991.5	1041.5	1091.5	1141.5
A		274.5	324.5	374.5	424.5	474.5	524.5	574.5	624.5	674.5	724.5	774.5	824.5	874.5	924.5
B		215	265	315	365	415	465	515	565	615	665	715	765	815	865
C		115	65	115	65	115	65	115	65	115	65	115	65	115	65
D		0	1	1	2	2	3	3	4	4	5	5	6	6	7
E		4	6	6	8	8	10	10	12	12	14	14	16	16	18
J		115	165	215	265	315	365	415	465	515	565	615	665	715	765
Allowable static load on rod tip (N)		222	186	159	139	124	111	101	92	84.7	78.4	72.8	68	63.7	59.8
Allowable dynamic load on rod tip (5000km life) (N)	Load offset 0mm	93	76.3	64.7	56	49.2	43.8	39.3	35.6	32.4	29.7	27.3	25.2	23.3	21.7
	Load offset 100mm	72	61.6	53.9	48	43	38.9	35.4	32.3	29.7	27.4	25.3	23.5	21.9	20.4
Allowable static torque on rod tip (N-m)		22.3	18.7	16.1	14.1	12.6	11.3	10.3	9.4	8.7	8.1	7.6	7.1	6.7	6.3
Allowable dynamic torque on rod tip (N-m)		7.2	6.2	5.4	4.8	4.3	3.9	3.5	3.2	3	2.7	2.5	2.4	2.2	2
Mass (kg)	W/o brake	6.6	7.1	7.6	8.1	8.6	9.1	9.5	10.0	10.5	11.0	11.5	12.0	12.4	12.9
	W/ brake	7.2	7.7	8.2	8.7	9.2	9.7	10.1	10.6	11.1	11.6	12.1	12.6	13.0	13.5

**Applicable Controllers**

The RCS4 series actuators can be operated by the controllers indicated below. Please select the type depending on your intended use.

Name	External view	Max. number of connectable axes	Input power	Control method				Maximum number of positioning points	Reference page
				Positioner	Pulse train	Program	Network * Option		
SCON-CB/CGB		1	Single phase 200VAC	●	●	-	DeviceNet CC-Link CANopen CompoNet MECHATROLINK EtherCAT EtherNet/IP	512 (768 for network spec.)	Please contact IAI for more information.
SCON-LC/LCG		1		-	-	●		512 (768 for network spec.)	
SSEL-CS		2	Single phase 100V/200VAC	●	-	●	20000		
XSEL-P/Q/RA/SA		8	Single phase 200VAC Three-phase 200VAC	-	-	●	55000 (Depending on the type)		

Note:  
The type of compatible networks will vary depending on the controller. Please refer to the reference page for more information.

Foreword  
Slider Type  
Wide Slider Type  
Rod Type  
Radial Cylinder  
Wide Radial Cylinder  
Table Type  
Cleanroom Slider  
Cleanroom Wide Slider  
Options  
Reference Data  
Controller

# RCS4-RAA4R

Battery-less Absolute

Motor Unit Type

Side-mounted Motor

Body Width 40\* mm

200v AC Servo Motor

Model Specification Items	<b>RCS4</b> — <b>RAA4R</b> — <b>WA</b> — <b>60</b> — <input type="checkbox"/> — <input type="checkbox"/> — <b>T2</b> — <input type="checkbox"/> — <input type="checkbox"/>	* Body width does not include the width of the side-mounted motor.						
Series	Type	Encoder Type	Motor Type	Lead	Stroke	Applicable Controllers	Cable Length	Options
WA: Battery-less Absolute	60: Servo motor 60W	16: 16mm 10: 10mm 5: 5mm 2.5: 2.5mm	60: 60mm 410: 410mm (50mm increments)	T2: SCON MSCON SSEL XSEL-P/Q XSEL-RA/SA	N : None P : 1m S : 3m M : 5m X□ : Specified Length R□ : Robot Cable	Refer to Options table below.		



\* Depending on the model, there may be some limitations to using the vertical, side, and ceiling mount positions. Please refer to the Selection Notes on P.138 for more information.

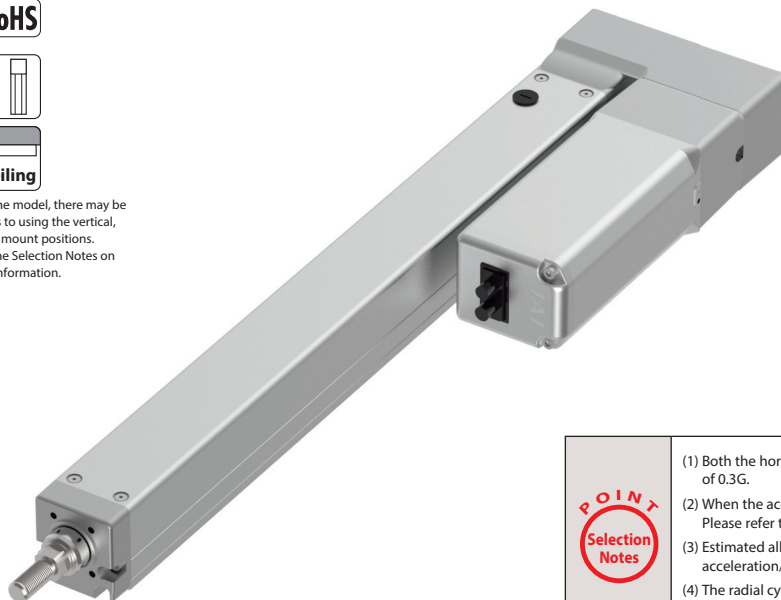

**POINT Selection Notes**

- (1) Both the horizontal and vertical payloads assume operation at an acceleration of 0.3G.
- (2) When the acceleration is increased, the payload will be reduced. Please refer to "Table of Payload by Acceleration" on P.139 for more details.
- (3) Estimated allowable duty varies depending on operating conditions (payload, acceleration/deceleration, etc.). Please refer to P. 149 for more information.
- (4) The radial cylinder is equipped with a built-in guide. Please refer to the graphs shown on P.145 and after for the allowable load mass.

## Actuator Specifications

### Lead and Payload

Model Number	Motor wattage (W)	Lead (mm)	Max. payload		Rated thrust (N)	Stroke (mm)
			Horizontal (kg)	Vertical (kg)		
RCS4-RAA4R-WA-60-16-①-T2-②-③	60	16	8	2	53	60~410 (50mm increments)
RCS4-RAA4R-WA-60-10-①-T2-②-③		10	18	4	85	
RCS4-RAA4R-WA-60-5-①-T2-②-③		5	30	6	170	
RCS4-RAA4R-WA-60-2.5-①-T2-②-③		2.5	40	10	340	

Legend: ① Stroke ② Cable Length ③ Option

### Stroke and Max Speed (Unit: mm/s)

Lead	Stroke (50mm increments)	60~410
		Max Speed
16	960	
10	600	
5	300	
2.5	150	

### ① Stroke

① Stroke (mm)	RCS4-RAA4R	① Stroke (mm)	RCS4-RAA4R
60	○	260	○
110	○	310	○
160	○	360	○
210	○	410	○

### ② Cable Length

Type	Cable Code
Standard	P(1m)
	S(3m)
	M(5m)
Specified length (Standard cable)	X06(6m) ~ X10(10m)
	X11(11m) ~ X15(15m)
	X16(16m) ~ X20(20m)
Robot cable	R01(1m) ~ R03(3m)
	R04(4m) ~ R05(5m)
	R06(6m) ~ R10(10m)
	R11(11m) ~ R15(15m)
	R16(16m) ~ R20(20m)

### ③ Options

Name	Option Code	Reference Page
Brake	B	See P.131
Cable exit direction (Top)	CJT	See P.131
Cable exit direction (Bottom)	CJB	See P.131
Cable exit direction (Outside)	CJO	See P.131
Flange	FL	See P.132
Tip adapter (Flange)	FFA	See P.131
Tip adapter (Keyway)	KFA	See P.134
Tip adapter (Internal thread)	NFA	See P.135
Motor side-mounted to left (standard)	ML	See P.135
Motor side-mounted to right	MR	See P.135
Non-motor end specification	NM	See P.136
Back mounting plate	RP	See P.137

\* Be sure to confirm with the "Selection Notes (P.138)" when selecting options.

## Actuator Specifications

Item	Description
Drive system	Ball screw φ8mm, rolled C10
Positioning repeatability	±0.01mm
Lost motion	0.1mm or less
Rod	φ20mm Material: Aluminum with hard alumite treatment
Rod non-rotation precision	0 degrees
Allowable load and torque on rod tip	Please see P. 68
Rod tip overhang distance	100mm
Ambient operating temp. & humidity	0~40°C, 85% RH or less (Non-condensing)

CAD drawings can be downloaded from our website.  
www.intelligentactuator.com



- \*1 The two mounting holes (H) on the rod side of the top surface cannot be used.  
(Note) When the rod is returning to its home position, please be mindful of possible interference from surrounding objects, as it will travel until it reaches the M.E.  
M.E: Mechanical end S.E: Stroke end
- \*2 The direction of width across flat varies depending on the product. Those flats cannot be used for vertical or horizontal reference plane.

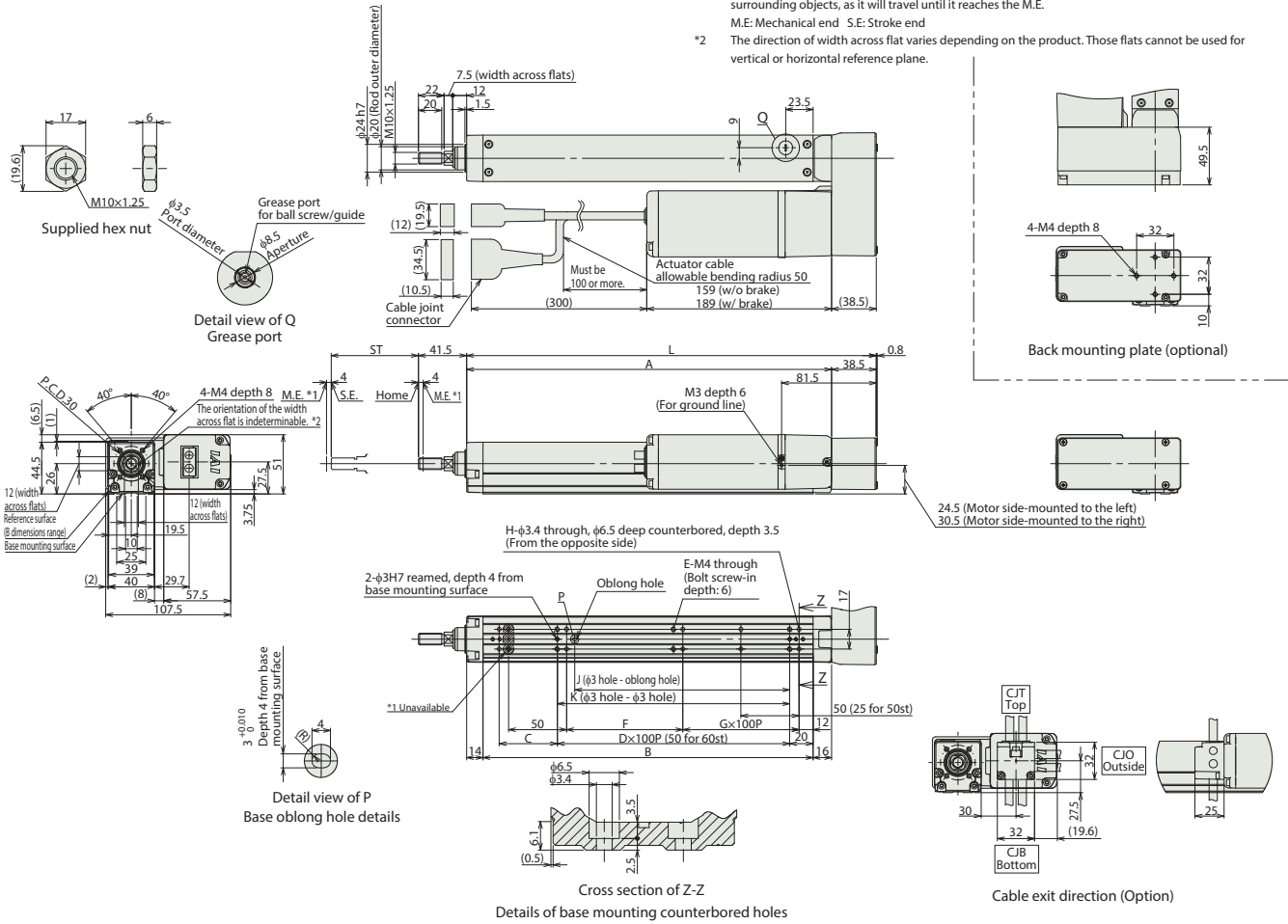

Dimensions and Mass by Stroke

Stroke	60	110	160	210	260	310	360	410
L	202.5	252.5	302.5	352.5	402.5	452.5	502.5	552.5
A	164	214	264	314	364	414	464	514
B	134	184	234	284	334	384	434	484
C	50	50	100	50	100	50	100	50
D	0	1	1	2	2	3	3	4
E	6	6	6	8	8	10	10	12
F	50	100	50	100	50	100	50	100
G	0	0	1	1	2	2	3	3
H *2	6	6	8	8	10	10	12	12
J	35	85	85	185	185	285	285	385
K	50	100	100	200	200	300	300	400
Allowable static load on rod tip (N)	63.4	50.7	42.1	36.0	31.3	27.6	24.6	22.2
Allowable dynamic load on rod tip (5000km life) (N)	28.9	22.2	17.9	14.8	12.6	10.8	9.4	8.2
Allowable static torque on rod tip (N-m)	6.4	5.1	4.3	3.7	3.2	2.9	2.6	2.3
Allowable dynamic torque on rod tip (N-m)	1.7	1.5	1.3	1.1	1.0	0.9	0.7	0.7
Mass (kg)	1.6	1.7	1.8	2.0	2.1	2.2	2.3	2.5
	W/o brake	1.9	2.0	2.1	2.3	2.4	2.5	2.8
	W/ brake							

\*2 Does not include holes that are not available.

Rod Deflection of RCS4-RR4R (Reference Values)

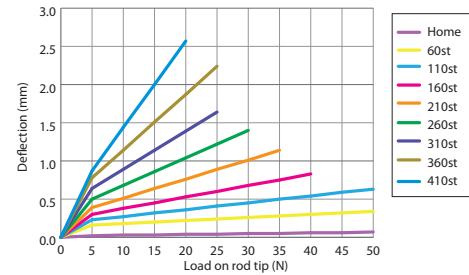

Applicable Controllers

The RCS4 series actuators can be operated by the controllers indicated below. Please select the type depending on your intended use.

Name	External view	Max. number of connectable axes	Input power	Control method				Maximum number of positioning points	Reference page	
				Positioner	Pulse train	Program	Network * Option			
SCON-CB/CGB		1	Single phase 100V/200VAC	●	●	—	DeviceNet CC-Link CC-Link IE CompoNet MECHATROLINK EtherCAT EtherNet/IP EtherCAT CC-Link	512 (768 for network spec.)	Please contact IAI for more information.	
SCON-LC/LCG		1		—	—	●		512 (768 for network spec.)		
SCON-CAL/CGAL		1		●	—	—		512 (768 for network spec.)		
MSCON-C		6		This model is network-compatible only.				256		
SSEL-CS		2		●	—	●		20000		
XSEL-P/Q/RA/SA		8	Single phase 200VAC Three-phase 200VAC	—	—	●	55000 (Depending on the type)			

Note: The type of compatible networks will vary depending on the controller. Please refer to the reference page for more information.

Foreword  
Slider Type  
Wide Slider Type  
Rod Type  
Radial Cylinder  
Wide Radial Cylinder  
Table Type  
Cleanroom Slider  
Cleanroom Wide Slider  
Options  
Reference Data  
Controller

# RCS4-RAA6R

Battery-less Absolute

Motor Unit Type

Side-mounted Motor

Body Width 60\* mm

200v AC Servo Motor

Model Specification Items	<b>RCS4</b> — <b>RAA6R</b> — <b>WA</b> — <b>100</b> — <input type="checkbox"/> — <input type="checkbox"/> — <input type="checkbox"/>	<b>T2</b> — <input type="checkbox"/> — <input type="checkbox"/>	* Body width does not include the width of the side-mounted motor.
Series	Type	Encoder Type	Motor Type
WA: Battery-less Absolute	100: Servo motor 100W	20:20mm 12:12mm 6: 6mm 3: 3mm	65:65mm 415:415mm (50mm increments)
Lead		Stroke	Applicable Controllers
T2:SCON MSCON SSEL XSEL-P/Q XSEL-RA/SA		N : None P : 1m S : 3m M : 5m	Cable Length
Options		Refer to Options table below.	
X <input type="checkbox"/> : Specified Length R <input type="checkbox"/> : Robot Cable			

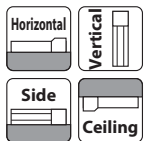

\* Depending on the model, there may be some limitations to using the vertical, side, and ceiling mount positions. Please refer to the Selection Notes on P.138 for more information.



- POINT Selection Notes**
- (1) Both the horizontal and vertical payloads assume operation at an acceleration of 0.3G.
  - (2) When the acceleration is increased, the payload will be reduced. Please refer to "Table of Payload by Acceleration" on P.139 for more details.
  - (3) Estimated allowable duty varies depending on operating conditions (payload, acceleration/deceleration, etc.). Please refer to P. 149 for more information.
  - (4) The radial cylinder is equipped with a built-in guide. Please refer to the graphs shown on P.145 and after for the allowable load mass.

## Actuator Specifications

### Lead and Payload

Model Number	Motor wattage (W)	Lead (mm)	Max. payload		Rated thrust (N)	Stroke (mm)
			Horizontal (kg)	Vertical (kg)		
RCS4-RAA6R-WA-100-20-①-T2-②-③	100	20	15	4	85	65~415 (50mm increments)
RCS4-RAA6R-WA-100-12-①-T2-②-③		12	25	9	142	
RCS4-RAA6R-WA-100-6-①-T2-②-③		6	50	19	283	
RCS4-RAA6R-WA-100-3-①-T2-②-③		3	60	20	566	

Legend: ① Stroke ② Cable Length ③ Option

### Stroke and Max Speed (Unit: mm/s)

Lead	Stroke	
	Stroke (50mm increments)	65~415
20		1200
12		720
6		360
3		180

### ① Stroke

① Stroke (mm)	RCS4-RAA6R	① Stroke (mm)	RCS4-RAA6R
65	<input type="checkbox"/>	265	<input type="checkbox"/>
115	<input type="checkbox"/>	315	<input type="checkbox"/>
165	<input type="checkbox"/>	365	<input type="checkbox"/>
215	<input type="checkbox"/>	415	<input type="checkbox"/>

### ② Cable Length

Type	Cable Code
Standard	P(1m)
	S(3m)
	M(5m)
Specified length (Standard cable)	X06(6m) ~ X10(10m)
	X11(11m) ~ X15(15m)
	X16(16m) ~ X20(20m)
Robot cable	R01(1m) ~ R03(3m)
	R04(4m) ~ R05(5m)
	R06(6m) ~ R10(10m)
	R11(11m) ~ R15(15m)
	R16(16m) ~ R20(20m)

### ③ Options

Name	Option Code	Reference Page
Brake	<b>B</b>	See P.131
Cable exit direction (Top)	<b>CJT</b>	See P.131
Cable exit direction (Bottom)	<b>CJB</b>	See P.131
Cable exit direction (Outside)	<b>CJO</b>	See P.131
Flange	<b>FL</b>	See P.132
Tip adapter (Flange)	<b>FFA</b>	See P.131
Tip adapter (Keyway)	<b>KFA</b>	See P.134
Tip adapter (Internal thread)	<b>NFA</b>	See P.135
Motor side-mounted to left (standard)	<b>ML</b>	See P.135
Motor side-mounted to right	<b>MR</b>	See P.135
Non-motor end specification	<b>NM</b>	See P.136

\* Be sure to confirm with the "Selection Notes (P.138)" when selecting options.

## Actuator Specifications

Item	Description
Drive system	Ball screw φ10mm, rolled C10
Positioning repeatability	±0.01mm
Lost motion	0.1mm or less
Rod	φ25mm Material: Aluminum with hard alumite treatment
Rod non-rotation precision	0 degrees
Allowable load and torque on rod tip	Please see P. 70
Rod tip overhang distance	100mm
Ambient operating temp. & humidity	0~40°C, 85% RH or less (Non-condensing)



\*1 When the rod is returning to its home position, please be careful of interference from surrounding objects, as it will travel until it reaches the M.E.  
M.E: Mechanical end S.E: Stroke end  
\*2 The direction of width across flats varies depending on the product. Those flats cannot be used for vertical horizontal reference plane.

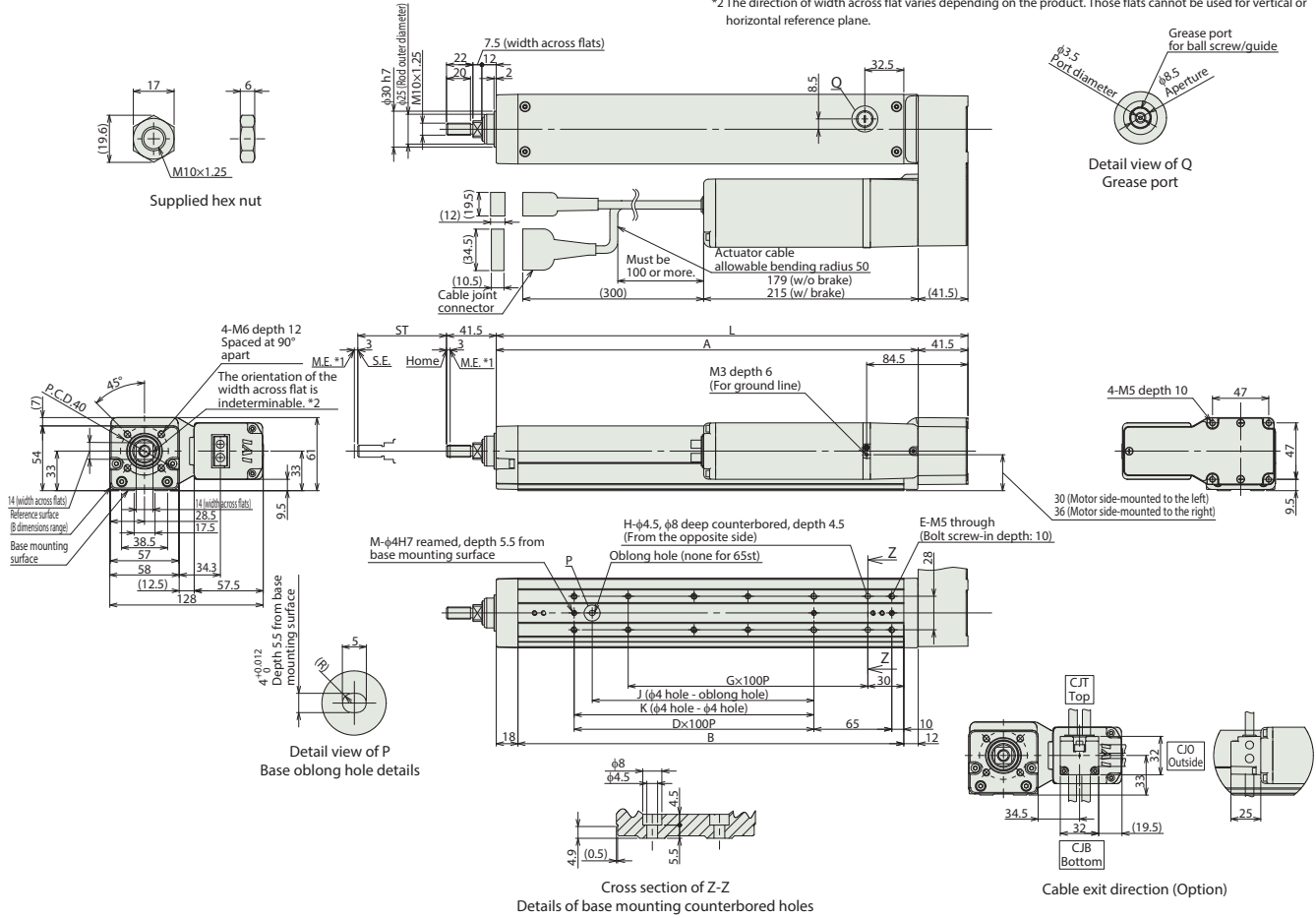

■ Dimensions and Mass by Stroke

Stroke	65	115	165	215	265	315	365	415	
L	243.5	293.5	343.5	393.5	443.5	493.5	543.5	593.5	
A	202	252	302	352	402	452	502	552	
B	172	222	272	322	372	422	472	522	
D	0	1	1	2	2	3	3	4	
E	4	6	6	8	8	10	10	12	
G	1	1	2	2	3	3	4	4	
H	4	4	6	6	8	8	10	10	
J	0	85	85	185	185	285	285	385	
K	0	100	100	200	200	300	300	400	
M	2	3	3	3	3	3	3	3	
Allowable static load on rod tip (N)	144	117	99	85.4	75	66.7	59.9	54.3	
Allowable dynamic load on rod tip (5000km life) (N)	58.1	46.4	38.3	32.4	27.9	24.4	21.5	19.2	
Allowable static torque on rod tip (N-m)	14.5	11.8	10.0	8.7	7.6	6.8	6.2	5.6	
Allowable dynamic torque on rod tip (N-m)	3.8	3.3	2.9	2.6	2.3	2.0	1.8	1.6	
Mass (kg)	W/o brake	2.5	2.7	2.9	3.2	3.4	3.6	3.9	4.1
	W/ brake	2.8	3.0	3.2	3.5	3.7	3.9	4.2	4.4

■ Rod Deflection of RCS4-RRR6R (Reference Values)

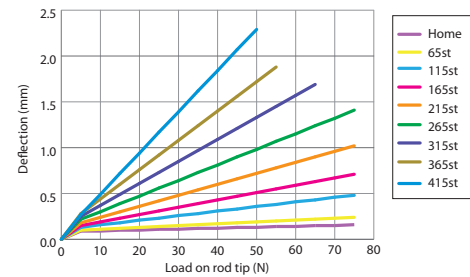

■ Applicable Controllers

The RCS4 series actuators can be operated by the controllers indicated below. Please select the type depending on your intended use.

Name	External view	Max. number of connectable axes	Input power	Control method				Maximum number of positioning points	Reference page	
				Positioner	Pulse train	Program	Network * Option			
SCON-CB/CGB		1	Single phase 100V/200VAC	●	●	—	<b>DeviceNet</b> <b>CC-Link</b> <b>PROFINET</b> <b>CompoNet</b> <b>MECHATROLINK</b> <b>EtherCAT</b> <b>EtherNet/IP</b>	512 (768 for network spec.)	Please contact IAI for more information.	
SCON-LC/LCG		1		—	—	●		512 (768 for network spec.)		
SCON-CAL/CGAL		1		●	—	—		512 (768 for network spec.)		
MSCON-C		6		This model is network-compatible only.				256		
SSEL-CS		2		●	—	●		20000		
XSEL-P/Q/RA/SA		8	Single phase 200VAC Three-phase 200VAC	—	—	●	55000 (Depending on the type)			

Note: The type of compatible networks will vary depending on the controller. Please refer to the reference page for more information.

Foreword  
Slider Type  
Wide Slider Type  
Rod Type  
Radial Cylinder  
Wide Radial Cylinder  
Table Type  
Cleanroom Slider  
Cleanroom Wide Slider  
Options  
Reference Data  
Controller

# RCS4-RAA7R

Battery-less Absolute

Motor Unit Type

Side-mounted Motor

Body Width 70\* mm

200v AC Servo Motor

Model Specification Items	<b>RCS4</b> — <b>RAA7R</b> — <b>WA</b> — <b>200</b> — <input type="checkbox"/> — <input type="checkbox"/> — <b>T2</b> — <input type="checkbox"/> — <input type="checkbox"/>	* Body width does not include the width of the side-mounted motor.						
Series	Type	Encoder Type	Motor Type	Lead	Stroke	Applicable Controllers	Cable Length	Options
WA: Battery-less Absolute	200: Servo motor 200W	24:24mm 16:16mm 8: 8mm 4: 4mm	70:70mm 520:520mm (50mm increments)	T2:SCON MSCON SSEL XSEL-P/Q XSEL-RA/SA	N : None P : 1m S : 3m M : 5m X <input type="checkbox"/> : Specified Length R <input type="checkbox"/> : Robot Cable	Refer to Options table below.		

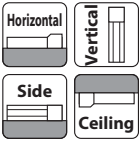

\* Depending on the model, there may be some limitations to using the vertical, side, and ceiling mount positions. Please refer to the Selection Notes on P.138 for more information.

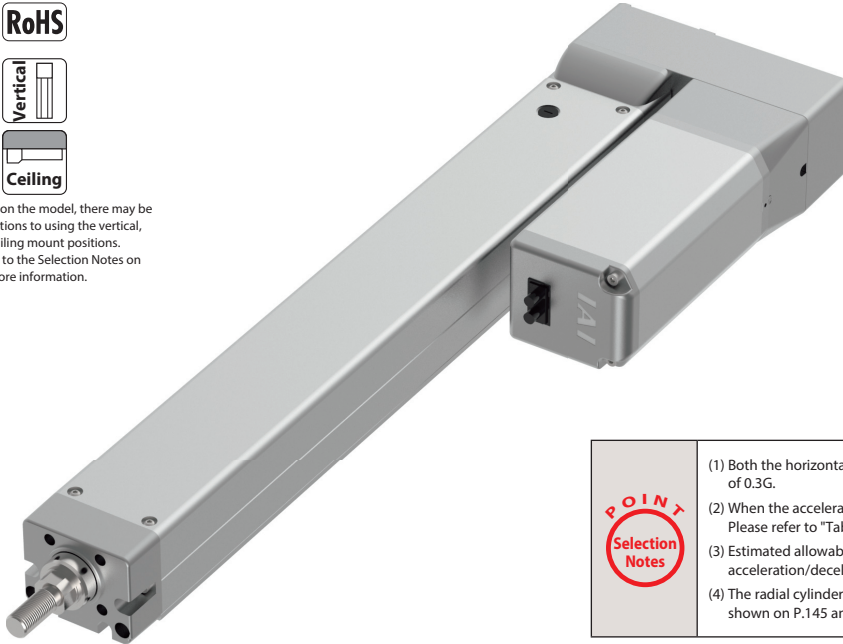

**POINT Selection Notes**

- (1) Both the horizontal and vertical payloads assume operation at an acceleration of 0.3G.
- (2) When the acceleration is increased, the payload will be reduced. Please refer to "Table of Payload by Acceleration" on P.139 for more details.
- (3) Estimated allowable duty varies depending on operating conditions (payload, acceleration/deceleration, etc.). Please refer to P. 149 for more information.
- (4) The radial cylinder is equipped with a built-in guide. Please refer to the graphs shown on P.145 and after for the allowable load mass.

## Actuator Specifications

### Lead and Payload

Model Number	Motor wattage (W)	Lead (mm)	Max. payload		Rated thrust (N)	Stroke (mm)
			Horizontal (kg)	Vertical (kg)		
RCS4-RAA7R-WA-200-24-①-T2-②-③	200	24	20	6	142	70~520 (50mm increments)
RCS4-RAA7R-WA-200-16-①-T2-②-③		16	45	12	214	
RCS4-RAA7R-WA-200-8-①-T2-②-③		8	60	25	427	
RCS4-RAA7R-WA-200-4-①-T2-②-③		4	80	35	855	

Legend: ① Stroke ② Cable Length ③ Option

### Stroke and Max Speed (Unit: mm/s)

Lead	Stroke (50mm increments)	70~520
		(mm/s)
24	1440	
16	960	
8	480	
4	240	

### ① Stroke

① Stroke (mm)	RCS4-RAA7R	① Stroke (mm)	RCS4-RAA7R
70	○	320	○
120	○	370	○
170	○	420	○
220	○	470	○
270	○	520	○

### ② Cable Length

Type	Cable Code
Standard	P(1m)
	S(3m)
	M(5m)
Specified length (Standard cable)	X06(6m) ~ X10(10m)
	X11(11m) ~ X15(15m)
	X16(16m) ~ X20(20m)
Robot cable	R01(1m) ~ R03(3m)
	R04(4m) ~ R05(5m)
	R06(6m) ~ R10(10m)
	R11(11m) ~ R15(15m)
	R16(16m) ~ R20(20m)

### ③ Options

Name	Option Code	Reference Page
Brake	B	See P.131
Cable exit direction (Top)	CJT	See P.131
Cable exit direction (Bottom)	CJB	See P.131
Cable exit direction (Outside)	CJO	See P.131
Flange	FL	See P.132
Tip adapter (Flange)	FFA	See P.131
Tip adapter (Keyway)	KFA	See P.134
Tip adapter (Internal thread)	NFA	See P.135
Motor side-mounted to left (standard)	ML	See P.135
Motor side-mounted to right	MR	See P.135
Non-motor end specification	NM	See P.136

## Actuator Specifications

Item	Description
Drive system	Ball screw φ12mm, rolled C10
Positioning repeatability	±0.01mm
Lost motion	0.1mm or less
Rod	φ30mm Material: Aluminum with hard alumite treatment
Rod non-rotation precision	0 degrees
Allowable load and torque on rod tip	Please see P. 72
Rod tip overhang distance	150mm
Ambient operating temp. & humidity	0~40°C, 85% RH or less (Non-condensing)

\* Be sure to confirm with the "Selection Notes (P.138)" when selecting options.





\*1 When the rod is returning to its home position, please be careful of interference from surrounding objects, as it will travel until it reaches the M.E.  
M.E: Mechanical end S.E: Stroke end  
\*2 The direction of width across flat varies depending on the product. Those flats cannot be used for vertical horizontal reference plane.

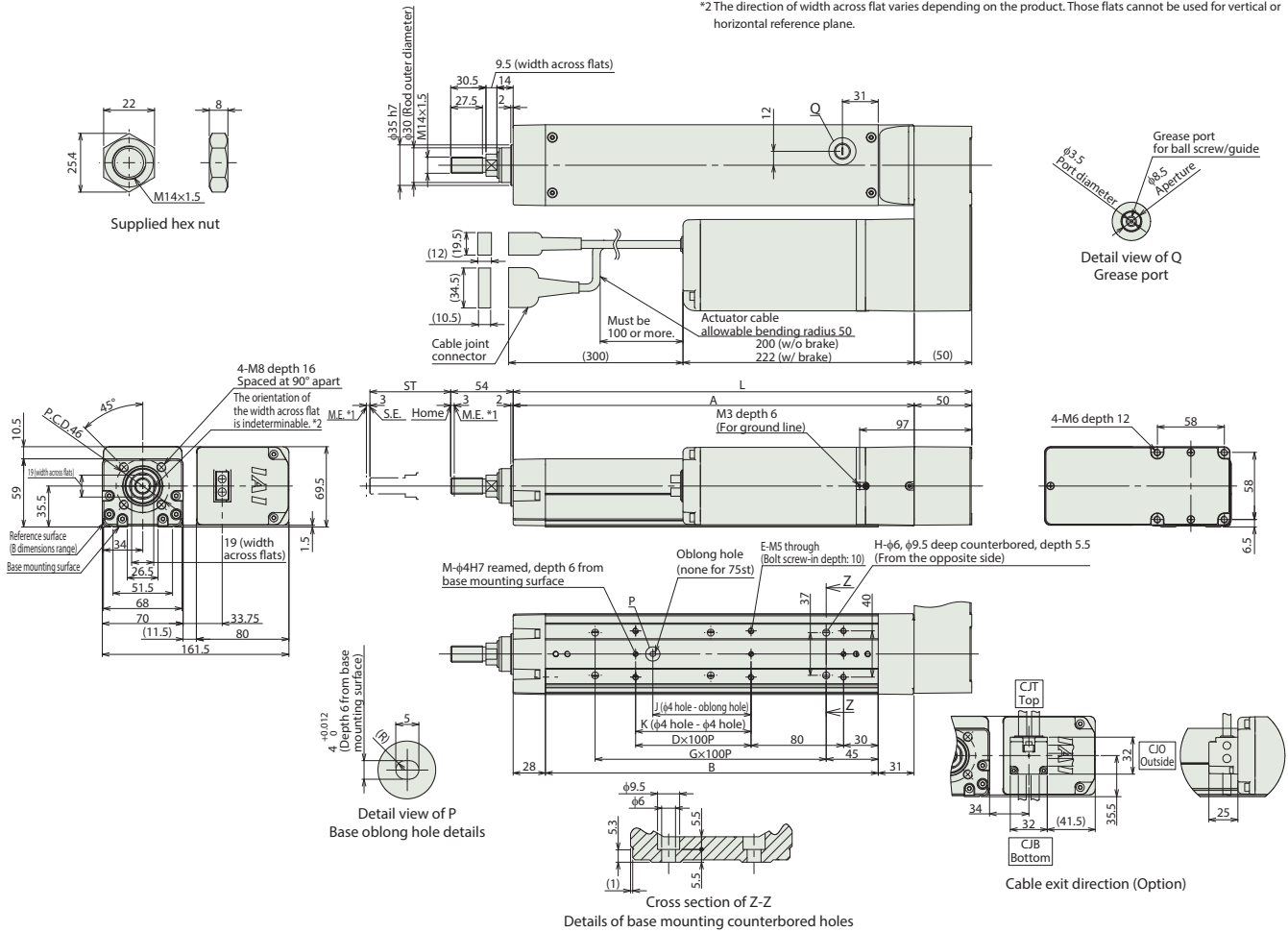

Dimensions and Mass by Stroke

Stroke	70	120	170	220	270	320	370	420	470	520
L	297	347	397	447	497	547	597	647	697	747
A	247	297	347	397	447	497	547	597	647	697
B	188	238	288	338	388	438	488	538	588	638
D	0	1	1	2	2	3	3	4	4	5
E	4	6	6	8	8	10	10	12	12	14
G	1	1	2	2	3	3	4	4	5	5
H	4	4	6	6	8	8	10	10	12	12
J	0	85	85	185	185	285	285	385	385	485
K	0	0	100	200	200	300	300	400	400	500
M	2	2	3	3	3	3	3	3	3	3
Allowable static load on rod tip (N)	175	147	126	111	98.6	88.7	80.6	73.8	68	63
Allowable dynamic load on rod tip (5000km life) (N)	75.7	62.6	53.1	46.0	40.5	36.1	32.5	29.4	26.9	24.7
Allowable static torque on rod tip (N-m)	17.6	14.7	12.7	11.2	9.9	9.0	8.2	7.5	6.94	6.45
Allowable dynamic torque on rod tip (N-m)	5.0	4.5	4.0	3.6	3.3	3.0	2.8	2.5	2.32	2.16
Mass (kg)	W/o brake	4.5	4.8	5.0	5.3	5.6	5.8	6.1	6.4	6.6
	W/brake	5.0	5.3	5.5	5.8	6.1	6.3	6.6	6.9	7.1

Rod Deflection of RCS4-RRR7R (Reference Values)

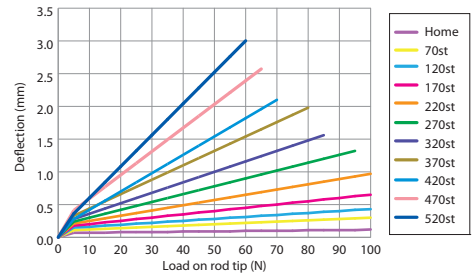

Applicable Controllers

The RCS4 series actuators can be operated by the controllers indicated below. Please select the type depending on your intended use.

Name	External view	Max. number of connectable axes	Input power	Control method				Maximum number of positioning points	Reference page	
				Positioner	Pulse train	Program	Network * Option			
SCON-CB/CGB		1	Single phase 100V/200VAC	●	●	-	DeviceNet CC-Link CC-Link IE CompoNet MECHATROLINK EtherCAT EtherNet/IP	512 (768 for network spec.)	Please contact IAI for more information.	
SCON-LC/LCG		1		-	-	●		512 (768 for network spec.)		
SCON-CAL/CGAL		1		●	-	-		512 (768 for network spec.)		
MSCON-C		6		This model is network-compatible only.				256		
SSEL-CS		2		●	-	●		20000		
XSEL-P/Q/RA/SA		8		Single phase 200VAC Three-phase 200VAC	-	-		●		55000 (Depending on the type)

Note: The type of compatible networks will vary depending on the controller. Please refer to the reference page for more information.

# RCS4-RRR8R

Battery-less Absolute

Motor Unit Type

Side-mounted Motor

Body Width 90\* mm

200v AC Servo Motor

Model Specification Items	<b>RCS4</b> — <b>RRR8R</b> — <b>WA</b> — <b>400</b> — <input type="checkbox"/> — <input type="checkbox"/> — <b>T2</b> — <input type="checkbox"/> — <input type="checkbox"/>	* Body width does not include the width of the side-mounted motor.						
Series	Type	Encoder Type	Motor Type	Lead	Stroke	Applicable Controllers	Cable Length	Options
WA: Battery-less Absolute	400: Servo motor 400W	30:30mm 20:20mm 10:10mm 5: 5mm	50:50mm 700:700mm (50mm increments)	T2:SCON SSEL XSEL-P/Q XSEL-RA/SA	N : None P : 1m S : 3m M : 5m	X <input type="checkbox"/> : Specified Length R <input type="checkbox"/> : Robot Cable	Refer to Options table below.	

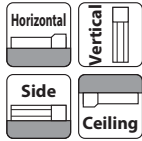

\* Depending on the model, there may be some limitations to using the vertical, side, and ceiling mount positions. Please refer to the Selection Notes on P.138 for more information.

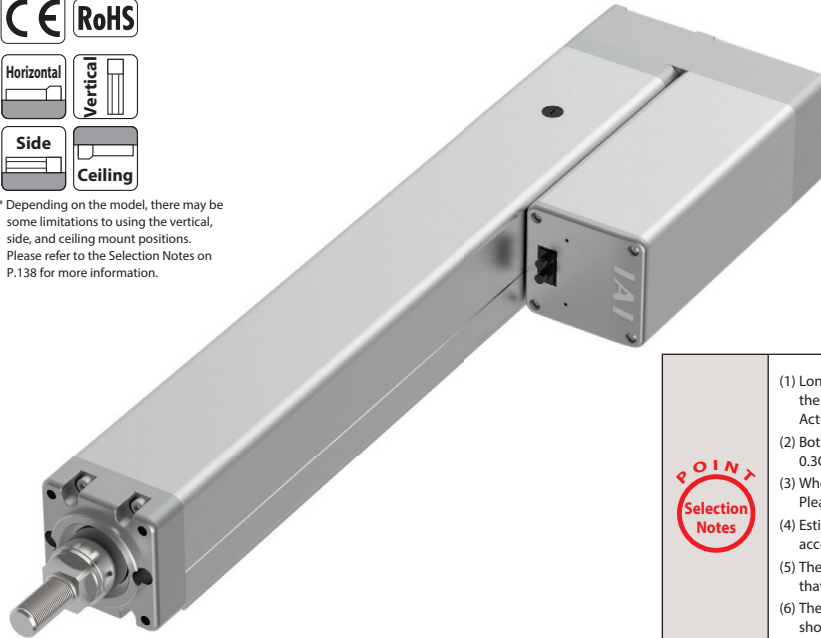

- (1) Longer strokes may cause the maximum speed to decrease due to resonance of the ball screw. Be sure to check the maximum speed of the desired stroke in the Actuator Specifications table, which can be found below
- (2) Both the horizontal and vertical payloads assume operation at an acceleration of 0.3G. (0.2G for lead 5).
- (3) When the acceleration is increased, the payload will be reduced. Please refer to "Table of Payload by Acceleration" on P.139 for more details.
- (4) Estimated allowable duty varies depending on operating conditions (payload, acceleration/deceleration, etc.). Please refer to P. 149 for more information.
- (5) The value of the maximum payload assumes that there is an external force and that the rod is not subjected to external force other than in the moving direction.
- (6) The radial cylinder is equipped with a built-in guide. Please refer to the graphs shown on P.145 and after for the allowable load mass.

## Actuator Specifications

### Lead and Payload

Model Number	Motor wattage (W)	Lead (mm)	Max. payload		Rated thrust (N)	Stroke (mm)
			Horizontal (kg)	Vertical (kg)		
RCS4-RRR8R-WA-400-30-①-T2-②-③	400	30	30	8	226	50~700 (50mm increments)
RCS4-RRR8R-WA-400-20-①-T2-②-③		20	60	17	339	
RCS4-RRR8R-WA-400-10-①-T2-②-③		10	80	34	678	
RCS4-RRR8R-WA-400-5-①-T2-②-③		5	100	72	1357	

Legend: ① Stroke ② Cable Length ③ Option

### Stroke and Max Speed

(Unit: mm/s)

Stroke / Lead	Stroke (mm)									
	50~250 (50mm increments)	300	350	400	450	500	550	600	650	700
30	1300	1230	970	790	650	540	460	400	350	
20	1000	820	650	520	430	360	310	260	230	
10	550	520	400	310	250	210	180	150	130	110
5	275	250	190	150	120	100	80	70	60	55

### ① Stroke

① Stroke (mm)	RCS4-RRR8R	① Stroke (mm)	RCS4-RRR8R
50	○	400	○
100	○	450	○
150	○	500	○
200	○	550	○
250	○	600	○
300	○	650	○
350	○	700	○

### ② Cable Length

Type	Cable Code
Standard	P(1m)
	S(3m)
	M(5m)
Specified length (Standard cable)	X06(6m) ~ X10(10m)
	X11(11m) ~ X15(15m)
	X16(16m) ~ X20(20m)
Robot cable	R01(1m) ~ R03(3m)
	R04(4m) ~ R05(5m)
	R06(6m) ~ R10(10m)
	R11(11m) ~ R15(15m)
	R16(16m) ~ R20(20m)

### ③ Options

Name	Option Code	Reference Page
Brake	B	See P.131
Cable exit direction (Top)	CJT	See P.131
Cable exit direction (Bottom)	CJB	See P.131
Cable exit direction (Outside)	CJO	See P.131
Flange	FL	See P.132
Tip adapter (Internal thread)	NFA	See P.135
Motor side-mounted to left (standard)	ML	See P.135
Motor side-mounted to right	MR	See P.135
Non-motor end specification	NM	See P.136

### Actuator Specifications

Item	Description
Drive system	Ball screw φ16mm, rolled C10
Positioning repeatability	±0.01mm
Lost motion	0.1 mm or less
Rod	φ40mm Material: Aluminum with hard alumite treatment
Rod non-rotation precision	0 degrees
Allowable load and torque on rod tip	Please see P. 74
Rod tip overhang distance	150mm
Ambient operating temp. & humidity	0~40°C, 85% RH or less (Non-condensing)

\* Be sure to confirm with the "Selection Notes (P.138)" when selecting options.



\*1 When the rod is returning to its home position, please be careful of interference from surrounding objects, as it will travel until it reaches the M.E.  
M.E: Mechanical end S.E: Stroke end  
\*2 The direction of width across flat varies depending on the product. Those flats cannot be used for vertical horizontal reference plane.

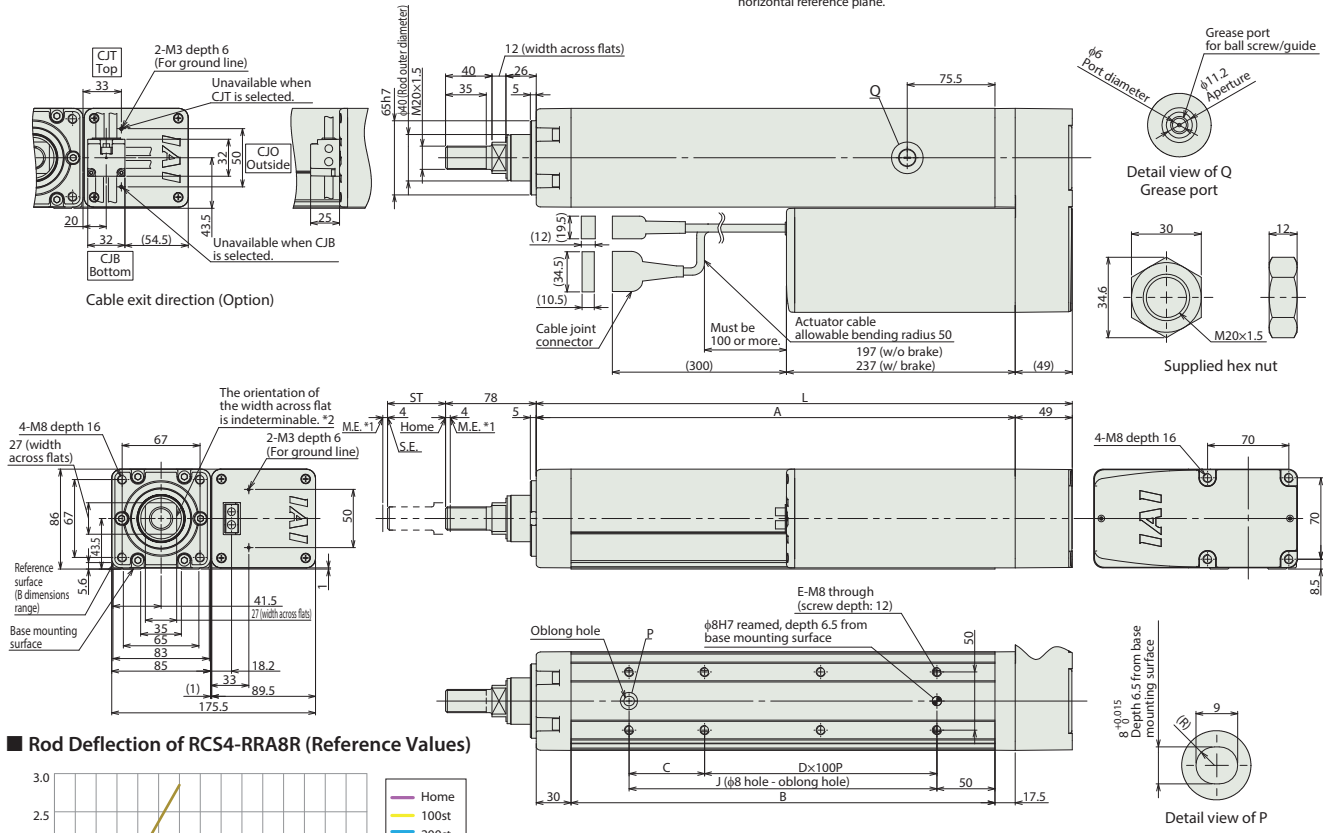

**■ Rod Deflection of RCS4-RRR48R (Reference Values)**

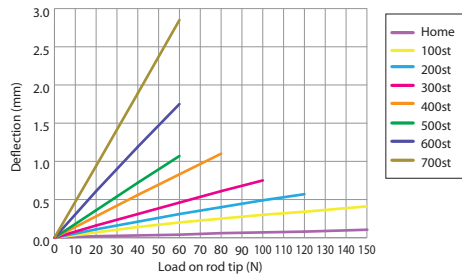

**■ Dimensions and Mass by Stroke**

Stroke	50	100	150	200	250	300	350	400	450	500	600	650	700
L	311.5	361.5	411.5	461.5	511.5	561.5	611.5	661.5	711.5	761.5	811.5	861.5	911.5
A	262.5	312.5	362.5	412.5	462.5	512.5	562.5	612.5	662.5	712.5	762.5	812.5	862.5
B	215	265	315	365	415	465	515	565	615	665	715	765	815
C	115	65	115	65	115	65	115	65	115	65	115	65	115
D	0	1	1	2	2	3	3	4	4	5	5	6	6
E	4	6	6	8	8	10	10	12	12	14	14	16	16
J	115	165	215	265	315	365	415	465	515	565	615	665	715
Allowable static load on rod tip (N)	222	186	159	139	124	111	101	92	84.7	78.4	72.8	68	63.7
Allowable dynamic load on rod tip (5000km life) (N)	Load offset 0mm		93	76.3	64.7	56	49.2	43.8	39.3	35.6	32.4	29.7	27.3
	Load offset 100mm		72	61.6	53.9	48	43	38.9	35.4	32.3	29.7	27.4	25.3
Allowable static torque on rod tip (N-m)	22.3	18.7	16.1	14.1	12.6	11.3	10.3	9.4	8.7	8.1	7.6	7.1	6.7
Allowable dynamic torque on rod tip (N-m)	7.2	6.2	5.4	4.8	4.3	3.9	3.5	3.2	3	2.7	2.5	2.4	2.2
Mass (kg)	W/o brake		7.9	8.3	8.8	9.3	9.8	10.3	10.8	11.2	11.7	12.2	12.7
	W/ brake		8.5	8.9	9.4	9.9	10.4	10.9	11.4	11.8	12.3	12.8	13.3

**Applicable Controllers**

The RCS4 series actuators can be operated by the controllers indicated below. Please select the type depending on your intended use.

Name	External view	Max. number of connectable axes	Input power	Control method				Maximum number of positioning points	Reference page
				Positioner	Pulse train	Program	Network * Option		
SCON-CB/CGB		1	Single phase 200VAC	●	●	-	<b>DeviceNet</b> <b>CC-Link</b> <b>PROFINET</b> <b>CompoNet</b> <b>MECHATROLINK</b> <b>EtherCAT</b> <b>EtherNet/IP</b> Note: The type of compatible networks will vary depending on the controller. Please refer to the reference page for more information.	512 (768 for network spec.)	Please contact IAI for more information.
SCON-LC/LCG		1		-	-	●		512 (768 for network spec.)	
SSEL-CS		2	Single phase 100V/200VAC	●	-	●		20000	
XSEL-P/Q/RA/SA		8	Single phase 200VAC Three-phase 200VAC	-	-	●		55000 (Depending on the type)	

# RCS4-WRA10C

Battery-less Absolute

Motor Unit Type

Coupled Motor

Body Width 100 mm

200v AC Servo Motor

Model Specification Items	<b>RCS4</b> — <b>WRA10C</b> — <b>WA</b> — <b>60</b> — <input type="checkbox"/> — <input type="checkbox"/> — <b>T2</b> — <input type="checkbox"/> — <input type="checkbox"/>							
Series	Type	Encoder Type	Motor Type	Lead	Stroke	Applicable Controllers	Cable Length	Options
		WA: Battery-less Absolute	60: Servo motor 60W	16: 16mm 10: 10mm 5: 5mm 2.5: 2.5mm	50: 50mm 500: 500mm (50mm increments)	T2: SCON MSCON SSEL XSEL-P/Q XSEL-RA/SA	N: None P: 1m S: 3m M: 5m X <input type="checkbox"/> : Specified Length R <input type="checkbox"/> : Robot Cable	Refer to Options table below. * Be sure to select a direction for the cable exit direction.

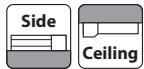

\* Depending on the model, there may be some limitations to using the vertical, side, and ceiling mount positions. Please refer to the Selection Notes on P.138 for more information.

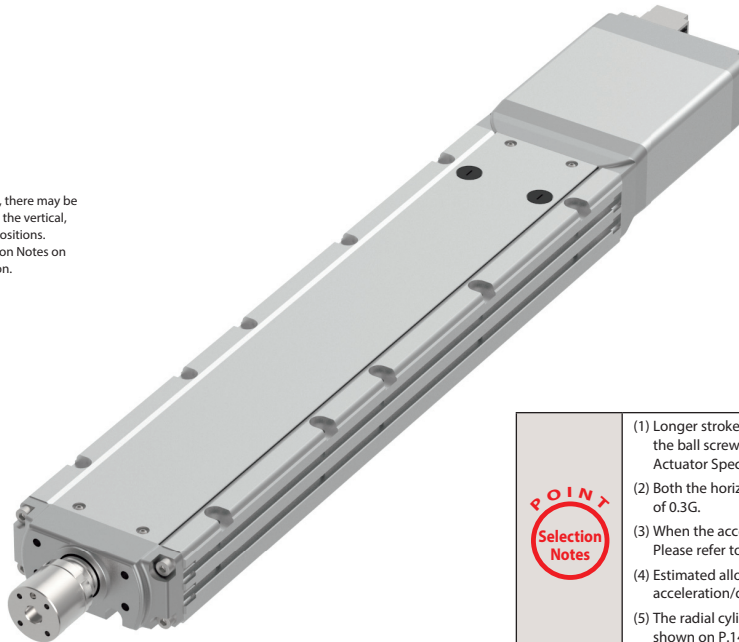

- POINT Selection Notes**
- (1) Longer strokes may cause the maximum speed to decrease due to resonance of the ball screw. Be sure to check the maximum speed of the desired stroke in the Actuator Specifications table, which can be found below.
  - (2) Both the horizontal and vertical payloads assume operation at an acceleration of 0.3G.
  - (3) When the acceleration is increased, the payload will be reduced. Please refer to "Table of Payload by Acceleration" on P.139 for more details.
  - (4) Estimated allowable duty varies depending on operating conditions (payload, acceleration/deceleration, etc.). Please refer to P.149 for more information.
  - (5) The radial cylinder is equipped with a built-in guide. Please refer to the graphs shown on P.147 and after for the allowable load mass.

## Actuator Specifications

### Lead and Payload

Model Number	Motor wattage (W)	Lead (mm)	Max. payload		Rated thrust (N)	Stroke (mm)
			Horizontal (kg)	Vertical (kg)		
RCS4-WRA10C-WA-60-16-①-T2-②-③	60	16	5	—	53	50~500 (50mm increments)
RCS4-WRA10C-WA-60-10-①-T2-②-③		10	16	3	85	
RCS4-WRA10C-WA-60-5-①-T2-②-③		5	25	5	170	
RCS4-WRA10C-WA-60-2.5-①-T2-②-③		2.5	40	10	340	

Legend: ① Stroke ② Cable Length ③ Option

### Stroke and Max Speed

(Unit: mm/s)

Lead	Stroke	50~400 (50mm increments)		450 (mm)	500 (mm)
		50~400 (mm)	450 (mm)		
16		800			770
10		600	580		490
5		300	290		240
2.5		150	145		120

### ① Stroke

① Stroke (mm)	RCS4-WRA10C	① Stroke (mm)	RCS4-WRA10C
50	○	300	○
100	○	350	○
150	○	400	○
200	○	450	○
250	○	500	○

### ② Cable Length

Type	Cable Code
Standard	P(1m)
	S(3m)
	M(5m)
Specified length (Standard cable)	X06(6m) ~ X10(10m)
	X11(11m) ~ X15(15m)
	X16(16m) ~ X20(20m)
Robot cable	R01(1m) ~ R03(3m)
	R04(4m) ~ R05(5m)
	R06(6m) ~ R10(10m)
	R11(11m) ~ R15(15m)
	R16(16m) ~ R20(20m)

### ③ Options

Name	Option Code	Reference Page
Brake	<b>B</b>	See P.131
Cable exit direction (Top)	<b>CJT</b>	See P.131
Cable exit direction (Right)	<b>CJR</b>	See P.131
Cable exit direction (Left)	<b>CJL</b>	See P.131
Cable exit direction (Bottom)	<b>CJB</b>	See P.131
Flange	<b>FL</b>	See P.132
Non-motor end specification	<b>NM</b>	See P.136
T-slot nut bar (Left)	<b>NTBL</b>	See P.136
T-slot nut bar (Right)	<b>NTBR</b>	See P.136

### Actuator Specifications

Item	Description
Drive system	Ball screw φ8mm, rolled C10
Positioning repeatability	±0.01mm
Lost motion	0.1mm or less
Rod	φ25mm Stainless steel
Rod non-rotation precision	0 degrees
Allowable load and torque on rod tip	Please see P. 76
Rod tip overhang distance	100mm or less
Ambient operating temp. & humidity	0~40°C, 85% RH or less (Non-condensing)



\*1 When the rod is returning to its home position, please be careful of interference from surrounding objects, as it will travel until it reaches the M.E.  
M.E: Mechanical end S.E: Stroke end

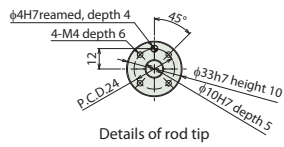

Details of rod tip

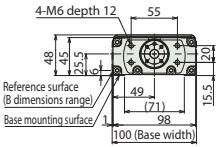

Detail view of P Base oblong hole details

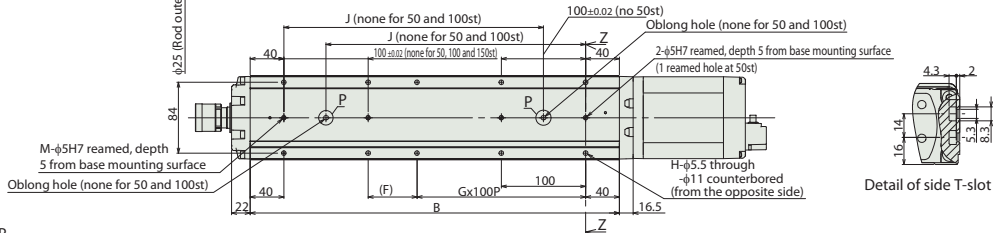
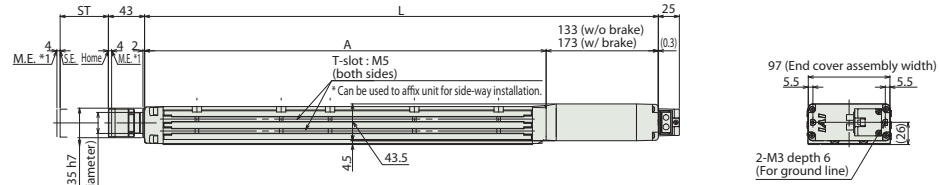
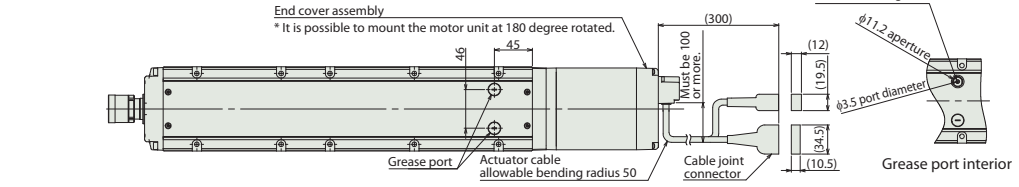

Detail of side T-slot

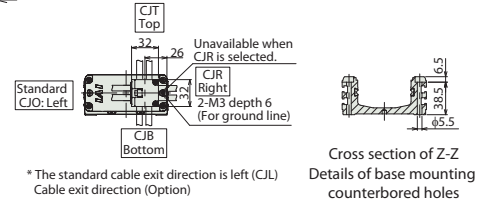

Cross section of Z-Z Details of base mounting counterbored holes

Dimensions and Mass by Stroke

ST		50	100	150	200	250	300	350	400	450	500
L	W/o brake	359.5	409.5	459.5	509.5	559.5	609.5	659.5	709.5	759.5	809.5
	W/ brake	399.5	449.5	499.5	549.5	599.5	649.5	699.5	749.5	799.5	849.5
A		226.5	276.5	326.5	376.5	426.5	476.5	526.5	576.5	626.5	676.5
B		188	238	288	338	388	438	488	538	588	638
F		108	58	108	58	108	58	108	58	108	58
G		0	1	1	1	1	2	2	3	3	4
H		4	6	6	8	8	10	10	12	12	14
J		-	-	158	208	258	308	358	408	458	508
M		1	1	1	2	2	2	2	2	2	2
Allowable static load on rod tip (N)		196	196	196	196	196	196	196	196	184	169
Allowable static torque on rod tip (N-m)		10	10	10	10	10	10	10	10	10	10
3000km	Allowable load on rod tip (N)	98	98	98	95	85	76	68	62	57	52
	Load offset 0mm	50	50	50	50	50	50	50	50	50	49
	Allowable dynamic torque on rod tip (N-m)	5.0	5.0	5.0	5.0	5.0	5.0	5.0	5.0	5.0	4.9
	Load offset 100mm	5.0	5.0	5.0	5.0	5.0	5.0	5.0	5.0	5.0	4.9
5000km	Allowable load on rod tip (N)	98	98	91	80	71	63	57	52	47	43
	Load offset 0mm	50	50	50	50	50	50	50	48	44	40
	Allowable dynamic torque on rod tip (N-m)	5.0	5.0	5.0	5.0	5.0	5.0	5.0	4.8	4.4	4.0
	Load offset 100mm	5.0	5.0	5.0	5.0	5.0	5.0	5.0	4.8	4.4	4.0
Mass (kg)	W/o brake	3.3	3.8	4.2	4.7	5.1	5.6	6.0	6.5	6.9	7.4
	W/ brake	3.6	4.1	4.5	5.0	5.4	5.9	6.3	6.8	7.2	7.7

Rod Deflection of RCS4-WRA10C (Reference Values)

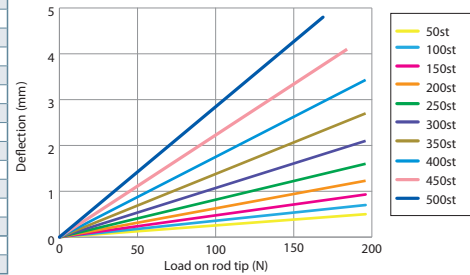

Applicable Controllers

The RCS4 series actuators can be operated by the controllers indicated below. Please select the type depending on your intended use.

Name	External view	Max. number of connectable axes	Input power	Control method				Maximum number of positioning points	Reference page	
				Positioner	Pulse train	Program	Network * Option			
SCON-CB/CGB		1	Single phase 100V/200VAC	●	●	-	<b>DeviceNet</b> <b>CC-Link</b> <b>PROFINET</b> <b>CompoNet</b> <b>MECHATROLINK</b> <b>EtherCAT</b> <b>EtherNet/IP</b>	512 (768 for network spec.)	Please contact IAI for more information.	
SCON-LC/LCG		1		-	-	●		512 (768 for network spec.)		
SCON-CAL/CGAL		1		●	-	-		512 (768 for network spec.)		
MSCON-C		6		This model is network-compatible only.				256		
SSEL-CS		2		●	-	●		20000		
XSEL-P/Q/RA/SA		8		Single phase 200VAC Three-phase 200VAC	-	-		●		55000 (Depending on the type)

Note:  
The type of compatible networks will vary depending on the controller. Please refer to the reference page for more information.

# RCS4-WRA12C

Battery-less Absolute

Motor Unit Type

Coupled Motor

Body Width  
120 mm

200v AC Servo Motor

Model Specification Items	<b>RCS4</b> — <b>WRA12C</b> — <b>WA</b> — <b>100</b> — <input type="checkbox"/> — <input type="checkbox"/> — <b>T2</b> — <input type="checkbox"/> — <input type="checkbox"/>
	Series — Type — Encoder Type — Motor Type — Lead — Stroke — Applicable Controllers — Cable Length — Options
	WA: Battery-less Absolute    100: Servo motor 100W    20:20mm 12:12mm 6: 6mm 3: 3mm    50:50mm 500:500mm (50mm increments)    T2:SCON MSCON SSEL XSEL-P/Q XSEL-RA/SA    N : None P : 1m S : 3m M : 5m X□□ : Specified Length R□□ : Robot Cable    Refer to Options table below. * Be sure to select a direction for the cable exit direction.

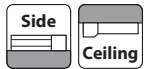

\* Depending on the model, there may be some limitations to using the vertical, side, and ceiling mount positions. Please refer to the Selection Notes on P.138 for more information.

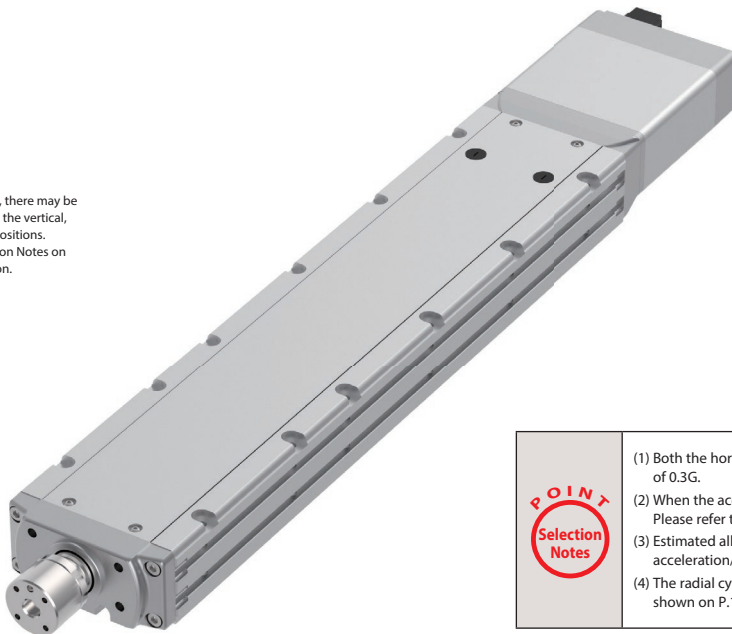

- POINT Selection Notes**
- (1) Both the horizontal and vertical payloads assume operation at an acceleration of 0.3G.
  - (2) When the acceleration is increased, the payload will be reduced. Please refer to "Table of Payload by Acceleration" on P.139 for more details.
  - (3) Estimated allowable duty varies depending on operating conditions (payload, acceleration/deceleration, etc.). Please refer to P. 149 for more information.
  - (4) The radial cylinder is equipped with a built-in guide. Please refer to the graphs shown on P.147 and after for the allowable load mass.

## Actuator Specifications

### Lead and Payload

Model Number	Motor wattage (W)	Lead (mm)	Max. payload		Rated thrust (N)	Stroke (mm)
			Horizontal (kg)	Vertical (kg)		
RCS4-WRA12C-WA-100-20-①-T2-②-③	100	20	12	2	85	50~500 (50mm increments)
RCS4-WRA12C-WA-100-12-①-T2-②-③		12	25	6	142	
RCS4-WRA12C-WA-100-6-①-T2-②-③		6	40	15	283	
RCS4-WRA12C-WA-100-3-①-T2-②-③		3	60	20	566	

Legend: ① Stroke ② Cable Length ③ Option

### Stroke and Max Speed (Unit: mm/s)

Lead	Stroke	50~500 (50mm increments)
20		1000
12		720
6		360
3		180

### ① Stroke

① Stroke (mm)	RCS4-WRA12C	① Stroke (mm)	RCS4-WRA12C
50	○	300	○
100	○	350	○
150	○	400	○
200	○	450	○
250	○	500	○

### ② Cable Length

Type	Cable Code
Standard	P(1m)
	S(3m)
	M(5m)
Specified length (Standard cable)	X06(6m) ~ X10(10m)
	X11(11m) ~ X15(15m)
	X16(16m) ~ X20(20m)
Robot cable	R01(1m) ~ R03(3m)
	R04(4m) ~ R05(5m)
	R06(6m) ~ R10(10m)
	R11(11m) ~ R15(15m)
	R16(16m) ~ R20(20m)

### ③ Options

Name	Option Code	Reference Page
Brake	<b>B</b>	See P.131
Cable exit direction (Top)	<b>CJT</b>	See P.131
Cable exit direction (Right)	<b>CJR</b>	See P.131
Cable exit direction (Left)	<b>CJL</b>	See P.131
Cable exit direction (Bottom)	<b>CJB</b>	See P.131
Flange	<b>FL</b>	See P.132
Non-motor end specification	<b>NM</b>	See P.136
T-slot nut bar (Left)	<b>NTBL</b>	See P.136
T-slot nut bar (Right)	<b>NTBR</b>	See P.136

### Actuator Specifications

Item	Description
Drive system	Ball screw φ10mm, rolled C10
Positioning repeatability	±0.01mm
Lost motion	0.1mm or less
Rod	φ30mm Stainless steel
Rod non-rotation precision	0 degrees
Allowable load and torque on rod tip	Please see P. 78
Rod tip overhang distance	100mm or less
Ambient operating temp. & humidity	0~40°C, 85% RH or less (Non-condensing)

CAD drawings can be downloaded from our website.  
www.intelligentactuator.com



\*1 When the rod is returning to its home position, please be careful of interference from surrounding objects, as it will travel until it reaches the M.E.  
M.E: Mechanical end S.E: Stroke end

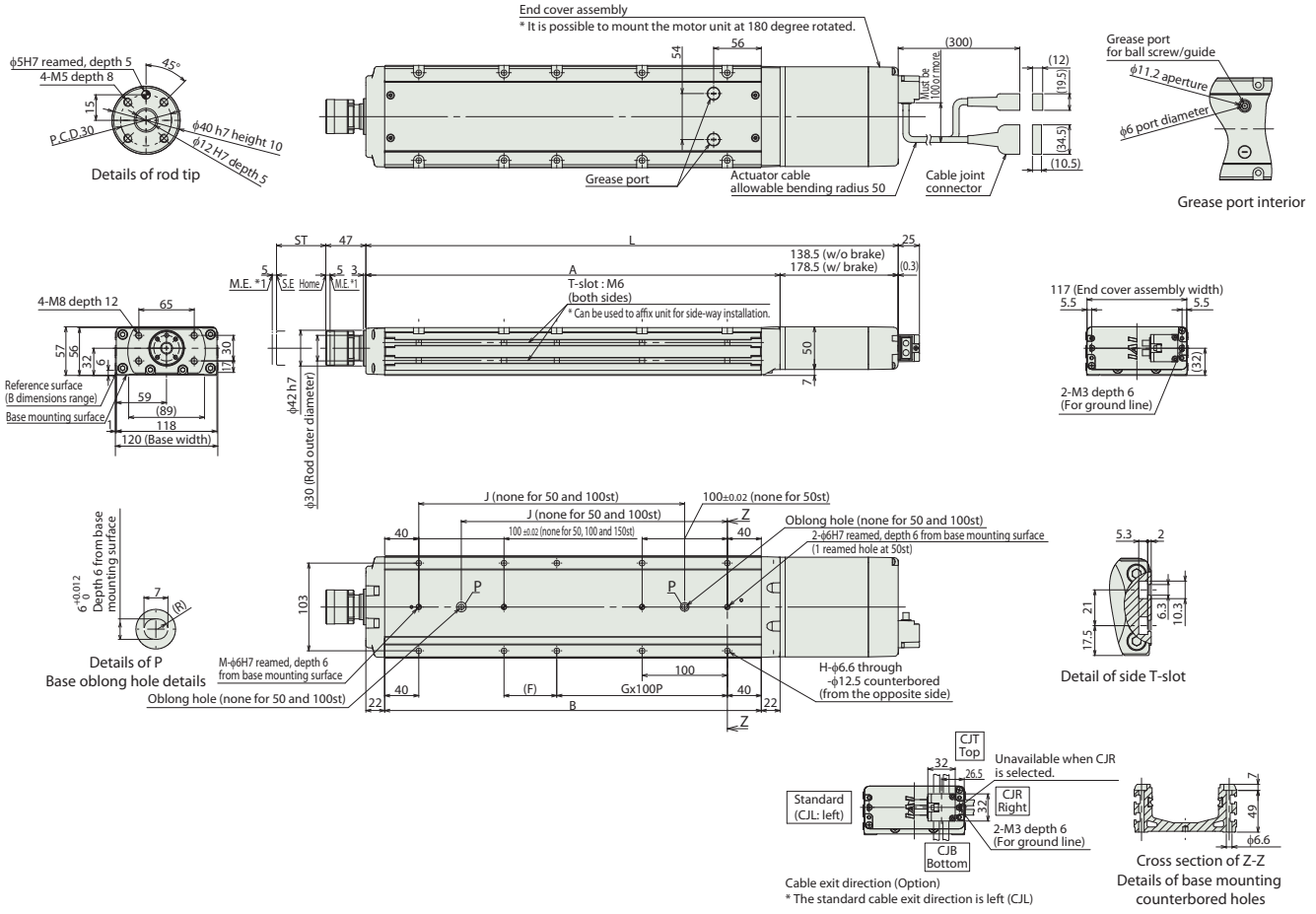

Dimensions and Mass by Stroke

L	ST	Stroke (mm)									
		50	100	150	200	250	300	350	400	450	500
W/o brake	374.5	424.5	474.5	524.5	574.5	624.5	674.5	724.5	774.5	824.5	
	414.5	464.5	514.5	564.5	614.5	664.5	714.5	764.5	814.5	864.5	
A	236	286	336	386	436	486	536	586	636	686	
B	192	242	292	342	392	442	492	542	592	642	
F	112	62	112	62	112	62	112	62	112	62	
G	0	1	1	1	1	2	2	3	3	4	
H	4	6	6	8	8	10	10	12	12	14	
J	-	-	162	212	262	312	362	412	462	512	
M	1	1	1	2	2	2	2	2	2	2	
Allowable static load on rod tip (N)	294	294	294	294	294	269	241	218	198	181	
Allowable static torque on rod tip (N-m)	20	20	20	20	20	20	20	20	20	20	
3000km	Allowable load on rod tip (N)	147	147	137	121	107	96	87	79	72	65
	Load offset 0mm	100	100	100	100	99	90	82	75	68	63
5000km	Allowable dynamic torque on rod tip (N-m)	10.0	10.0	10.0	10.0	9.9	9.0	8.2	7.5	6.8	6.3
	Allowable load on rod tip (N)	147	133	115	101	90	80	72	65	59	54
Mass (kg)	W/o brake	4.8	5.5	6.1	6.8	7.4	8.1	8.7	9.4	10.0	10.7
	W/ brake	5.1	5.8	6.4	7.1	7.7	8.4	9.0	9.7	10.3	11.0

Rod Deflection of RCS4-WRA12C (Reference Values)

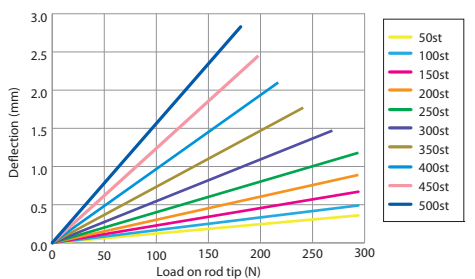

Applicable Controllers

The RCS4 series actuators can be operated by the controllers indicated below. Please select the type depending on your intended use.

Name	External view	Max. number of connectable axes	Input power	Control method				Maximum number of positioning points	Reference page	
				Positioner	Pulse train	Program	Network * Option			
SCON-CB/CGB		1	Single phase 100V/200VAC	●	●	-	DeviceNet CC-Link CompoNet MECHATROLINK EtherCAT EtherNet/IP	512 (768 for network spec.)	Please contact IAI for more information.	
SCON-LC/LCG		1		-	-	●		512 (768 for network spec.)		
SCON-CAL/CGAL		1		●	-	-		512 (768 for network spec.)		
MSCON-C		6		This model is network-compatible only.				256		
SSEL-CS		2		●	-	●		20000		
XSEL-P/Q/RA/SA		8	Single phase 200VAC Three-phase 200VAC	-	-	●	55000 (Depending on the type)			

Note: The type of compatible networks will vary depending on the controller. Please refer to the reference page for more information.

# RCS4-WRA14C

Battery-less Absolute

Motor Unit Type

Coupled Motor

Body Width  
140 mm

200v AC Servo Motor

■ Model Specification Items  
**RCS4** — **WRA14C** — **WA** — **200** —  —  — **T2** —  —

WA: Battery-less Absolute

200: Servo motor 200W

24:24mm  
16:16mm  
8: 8mm  
4: 4mm

50:50mm  
600:600mm (50mm increments)

T2:SCON  
MSCON  
SSEL  
XSEL-P/Q  
XSEL-RA/SA

N : None  
P : 1m  
S : 3m  
M : 5m  
X□□ : Specified Length  
R□□ : Robot Cable

Refer to Options table below.  
\* Be sure to select a direction for the cable exit direction.

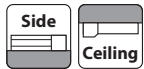

\* Depending on the model, there may be some limitations to using the vertical, side, and ceiling mount positions. Please refer to the Selection Notes on P.138 for more information.

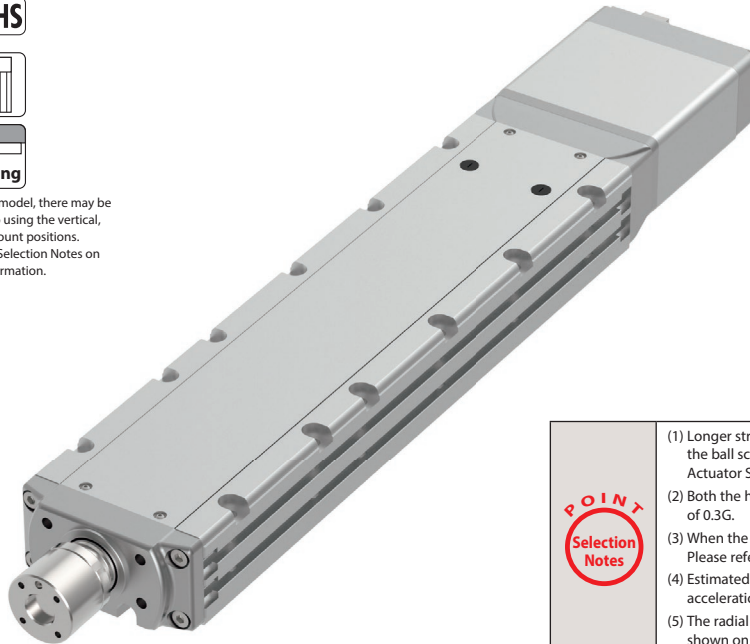

- POINT Selection Notes**
- (1) Longer strokes may cause the maximum speed to decrease due to resonance of the ball screw. Be sure to check the maximum speed of the desired stroke in the Actuator Specifications table, which can be found below.
  - (2) Both the horizontal and vertical payloads assume operation at an acceleration of 0.3G.
  - (3) When the acceleration is increased, the payload will be reduced. Please refer to "Table of Payload by Acceleration" on P.139 for more details.
  - (4) Estimated allowable duty varies depending on operating conditions (payload, acceleration/deceleration, etc.). Please refer to P.149 for more information.
  - (5) The radial cylinder is equipped with a built-in guide. Please refer to the graphs shown on P.147 and after for the allowable load mass.

## Actuator Specifications

### Lead and Payload

Model Number	Motor wattage (W)	Lead (mm)	Max. payload		Rated thrust (N)	Stroke (mm)
			Horizontal (kg)	Vertical (kg)		
RCS4-WRA14C-WA-200-24-①-T2-②-③	200	24	25	3	142	50~600 (50mm increments)
RCS4-WRA14C-WA-200-16-①-T2-②-③		16	50	8	214	
RCS4-WRA14C-WA-200-8-①-T2-②-③		8	65	20	427	
RCS4-WRA14C-WA-200-4-①-T2-②-③		4	85	30	855	

Legend: ① Stroke ② Cable Length ③ Option

### Stroke and Max Speed

(Unit: mm/s)

Lead	Stroke	50~600 (50mm increments)		
		50 (mm)	550 (mm)	600 (mm)
24		1200	1200	1200
16		800	800	800
8		480	450	390
4		240	220	190

### ① Stroke

① Stroke (mm)	RCS4-WRA14C	① Stroke (mm)	RCS4-WRA14C
50	○	350	○
100	○	400	○
150	○	450	○
200	○	500	○
250	○	550	○
300	○	600	○

### ② Cable Length

Type	Cable Code
Standard	P(1m)
	S(3m)
	M(5m)
Specified length (Standard cable)	X06(6m) ~ X10(10m)
	X11(11m) ~ X15(15m)
	X16(16m) ~ X20(20m)
Robot cable	R01(1m) ~ R03(3m)
	R04(4m) ~ R05(5m)
	R06(6m) ~ R10(10m)
	R11(11m) ~ R15(15m)
	R16(16m) ~ R20(20m)

### ③ Options

Name	Option Code	Reference Page
Brake	<b>B</b>	See P.131
Cable exit direction (Top)	<b>CJT</b>	See P.131
Cable exit direction (Right)	<b>CJR</b>	See P.131
Cable exit direction (Left)	<b>CJL</b>	See P.131
Cable exit direction (Bottom)	<b>CJB</b>	See P.131
Flange	<b>FL</b>	See P.132
Non-motor end specification	<b>NM</b>	See P.136
T-slot nut bar (Left)	<b>NTBL</b>	See P.136
T-slot nut bar (Right)	<b>NTBR</b>	See P.136

### Actuator Specifications

Item	Description
Drive system	Ball screw φ12mm, rolled C10
Positioning repeatability	±0.01mm
Lost motion	0.1 or less
Rod	φ40mm Stainless steel
Rod non-rotation precision	0 degrees
Allowable load and torque on rod tip	Please see P. 80
Rod tip overhang distance	150mm or less
Ambient operating temp. & humidity	0~40°C, 85% RH or less (Non-condensing)





# RCS4-WRA16C

Battery-less Absolute

Motor Unit Type

Coupled Motor

Body Width 160 mm

200v AC Servo Motor

Model Specification Items	<b>RCS4</b> — <b>WRA16C</b> — <b>WA</b> — <b>400</b> — <input type="checkbox"/> — <input type="checkbox"/> — <b>T2</b> — <input type="checkbox"/> — <input type="checkbox"/>							
Series	Type	Encoder Type	Motor Type	Lead	Stroke	Applicable Controllers	Cable Length	Options
		WA: Battery-less Absolute	400: Servo motor 400W	30:30mm 20:20mm 10:10mm 5: 5mm	50:50mm 800:800mm (50mm increments)	T2:SCON SSEL XSEL-P/Q XSEL-RA/SA	N : None P : 1m S : 3m M : 5m X <input type="checkbox"/> : Specified Length R <input type="checkbox"/> : Robot Cable	Refer to Options table below. * Be sure to select a direction for the cable exit direction.

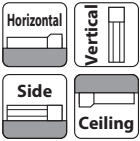

\* Depending on the model, there may be some limitations to using the vertical, side, and ceiling mount positions. Please refer to the Selection Notes on P.138 for more information.

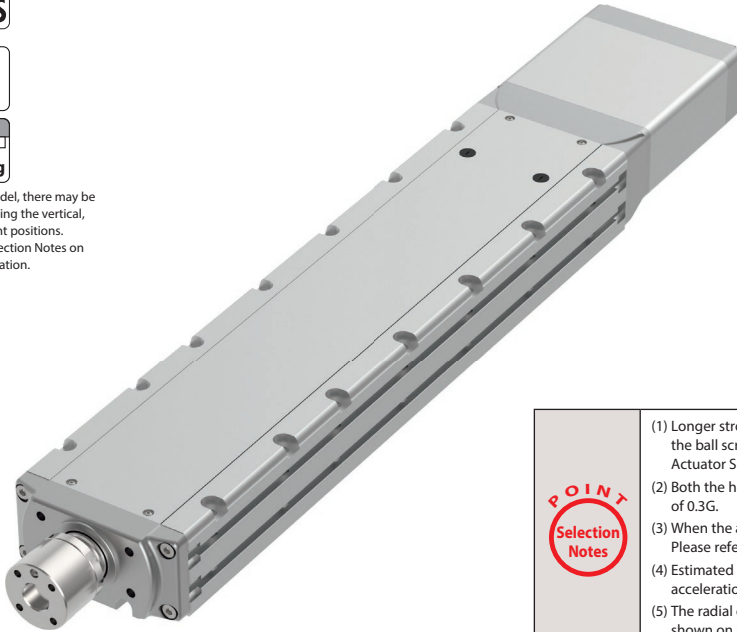

**POINT Selection Notes**

- (1) Longer strokes may cause the maximum speed to decrease due to resonance of the ball screw. Be sure to check the maximum speed of the desired stroke in the Actuator Specifications table, which can be found below.
- (2) Both the horizontal and vertical payloads assume operation at an acceleration of 0.3G.
- (3) When the acceleration is increased, the payload will be reduced. Please refer to "Table of Payload by Acceleration" on P.139 for more details.
- (4) Estimated allowable duty varies depending on operating conditions (payload, acceleration/deceleration, etc.). Please refer to P. 149 for more information.
- (5) The radial cylinder is equipped with a built-in guide. Please refer to the graphs shown on P.147 and after for the allowable load mass.

## Actuator Specifications

### Lead and Payload

Model Number	Motor wattage (W)	Lead (mm)	Max. payload		Rated thrust (N)	Stroke (mm)
			Horizontal (kg)	Vertical (kg)		
RCS4-WRA16C-WA-400-30-①-T2-②-③	400	30	30	6	226	50~800 (50mm increments)
RCS4-WRA16C-WA-400-20-①-T2-②-③		20	60	12	339	
RCS4-WRA16C-WA-400-10-①-T2-②-③		10	80	35	678	
RCS4-WRA16C-WA-400-5-①-T2-②-③		5	100	50	1357	

Legend: ① Stroke ② Cable Length ③ Option

### Stroke and Max Speed

(Unit: mm/s)

Stroke	Lead											
	50~250 (50mm increments)	300	350	400	450	500	550	600	650	700	750	800
30	1300	1050	860	710	600	510	440	390	340	300	270	
20	1000	880	700	570	400	340	295	260	225	200	180	
10	500	430	340	280	230	195	165	145	125	110	100	90
5	250	210	170	130	115	95	80	70	60	55	50	45

### ① Stroke

① Stroke (mm)	RCS4-WRA16C	① Stroke (mm)	RCS4-WRA16C
50	○	450	○
100	○	500	○
150	○	550	○
200	○	600	○
250	○	650	○
300	○	700	○
350	○	750	○
400	○	800	○

### ② Cable Length

Type	Cable Code
Standard	P(1m)
	S(3m)
	M(5m)
Specified length (Standard cable)	X06(6m) ~ X10(10m)
	X11(11m) ~ X15(15m)
	X16(16m) ~ X20(20m)
Robot cable	R01(1m) ~ R03(3m)
	R04(4m) ~ R05(5m)
	R06(6m) ~ R10(10m)
	R11(11m) ~ R15(15m)
	R16(16m) ~ R20(20m)

### ③ Options

Name	Option Code	Reference Page
Brake	B	See P.131
Cable exit direction (Top)	CJT	See P.131
Cable exit direction (Right)	CJR	See P.131
Cable exit direction (Left)	CJL	See P.131
Cable exit direction (Bottom)	CJB	See P.131
Flange	FL	See P.132
Non-motor end specification	NM	See P.136
T-slot nut bar (Left)	NTBL	See P.136
T-slot nut bar (Right)	NTBR	See P.136

### Actuator Specifications

Item	Description
Drive system	Ball screw φ16mm, rolled C10
Positioning repeatability	±0.01mm
Lost motion	0.1mm or less
Rod	φ45mm Stainless steel
Rod non-rotation precision	0 degrees
Allowable load and torque on rod tip	Please see P. 82
Rod tip overhang distance	150mm or less
Ambient operating temp. & humidity	0~40°C, 85% RH or less (Non-condensing)

CAD drawings can be downloaded from our website.  
www.intelligentactuator.com



\*1 When the rod is returning to its home position, please be careful of interference from surrounding objects, as it will travel until it reaches the M.E.

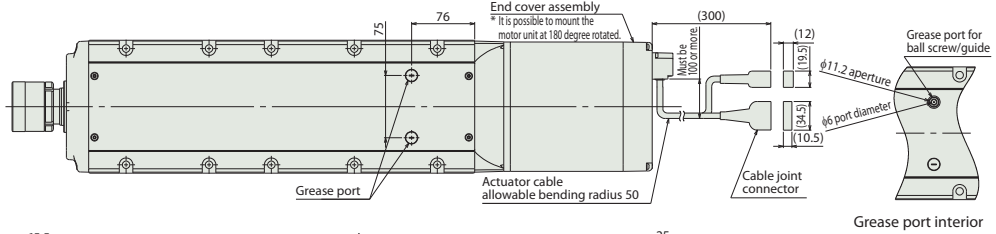
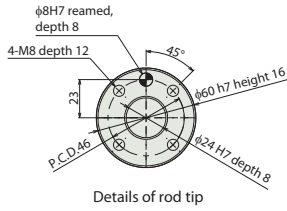

Grease port interior

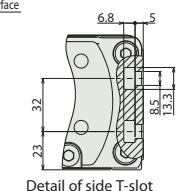
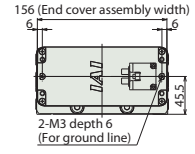
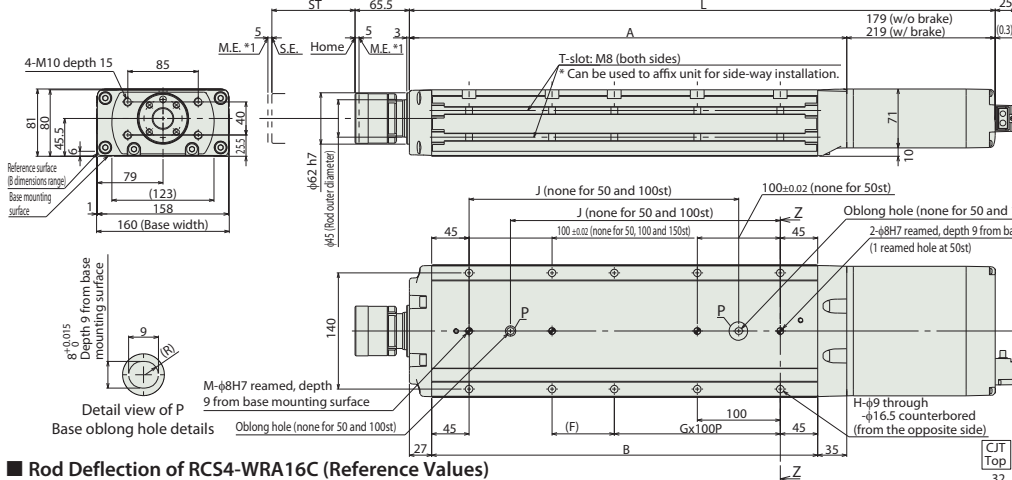

■ Rod Deflection of RCS4-WRA16C (Reference Values)

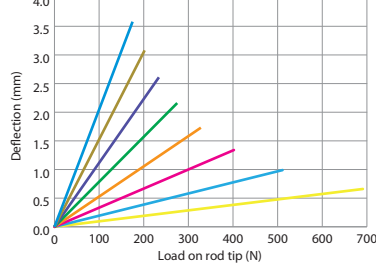

■ Dimensions and Mass by Stroke

ST		50	100	150	200	250	300	350	400	450	500	550	600	650	700	750	800
L	W/o brake	456	506	556	606	656	706	756	806	856	906	956	1006	1056	1106	1156	1206
	W/ brake	496	546	596	646	696	746	796	846	896	946	996	1046	1096	1146	1196	1246
A		277	327	377	427	477	527	577	627	677	727	777	827	877	927	977	1027
B		215	265	315	365	415	465	515	565	615	665	715	765	815	865	915	965
F		125	75	125	75	125	75	125	75	125	75	125	75	125	75	125	75
G		0	1	1	1	2	2	3	3	4	4	5	5	6	6	7	7
H		4	6	6	8	8	10	10	12	12	14	14	16	16	18	18	20
J		-	-	175	225	275	325	375	425	475	525	575	625	675	725	775	825
M		1	1	1	2	2	2	2	2	2	2	2	2	2	2	2	2
Allowable static load on rod tip (N)		588	588	588	511	451	402	362	329	300	275	254	235	217	202	188	176
Allowable static torque on rod tip (N-m)		40	40	40	40	40	40	40	40	40	40	40	40	40	40	40	40
3000km	Allowable load on rod tip (N)	255	220	191	168	149	134	120	109	99	90	81	74	67	61	55	50
	Load offset 100mm	133	133	133	133	133	122	111	101	92	84	77	70	64	58	53	48
Allowable dynamic torque on rod tip (N-m)		20.0	20.0	20.0	20.0	20.0	18.3	16.7	15.2	13.8	12.6	11.5	10.5	9.6	8.7	7.9	7.1
5000km	Allowable load on rod tip (N)	214	184	160	140	124	111	99	89	80	72	65	59	53	47	42	37
	Load offset 100mm	133	133	133	124	112	101	91	83	75	68	62	56	50	45	40	36
Allowable dynamic torque on rod tip (N-m)		20.0	20.0	20.0	18.6	16.8	15.2	13.7	12.4	11.3	10.2	9.2	8.4	7.5	6.8	6.0	5.3
Mass (kg)	W/o brake	11.4	12.5	13.6	14.8	15.9	17.1	18.2	19.4	20.5	21.7	22.8	24.0	25.1	26.3	27.4	28.6
	W/ brake	12.0	13.1	14.2	15.4	16.5	17.7	18.8	20.0	21.1	22.3	23.4	24.6	25.7	26.9	28.0	29.2

Applicable Controllers

The RCS4 series actuators can be operated by the controllers indicated below. Please select the type depending on your intended use.

Name	External view	Max. number of connectable axes	Input power	Control method				Maximum number of positioning points	Reference page
				Positioner	Pulse train	Program	Network * Option		
SCON-CB/CGB		1	Single phase 200VAC	●	●	-	<b>DeviceNet</b> <b>CC-Link</b> <b>CompoNet</b> <b>MECHATROLINK</b> <b>EtherCAT</b> <b>EtherNet/IP</b> Note: The type of compatible networks will vary depending on the controller. Please refer to the reference page for more information.	512 (768 for network spec.)	Please contact IAI for more information.
SCON-LC/LCG		1	Single phase 200VAC	-	-	●		512 (768 for network spec.)	
SSEL-CS		2	Single phase 100V/200VAC	●	-	●		20000	
XSEL-P/Q/RA/SA		8	Single phase 200VAC Three-phase 200VAC	-	-	●	55000 (Depending on the type)		

Foreword  
Slider Type  
Wide Slider Type  
Rod Type  
Radial Cylinder  
Wide Radial Cylinder  
Table Type  
Cleanroom Slider  
Cleanroom Wide Slider  
Options  
Reference Data  
Controller

# RCS4-WRA10R

Battery-less Absolute

Motor Unit Type

Side-mounted Motor

Body Width 100\* mm

200v AC Servo Motor

Model Specification Items	<b>RCS4</b> — <b>WRA10R</b> — <b>WA</b> — <b>60</b> — <input type="checkbox"/> — <input type="checkbox"/> — <b>T2</b> — <input type="checkbox"/> — <input type="checkbox"/>	* Body width does not include the width of the side-mounted motor.						
Series	Type	Encoder Type	Motor Type	Lead	Stroke	Applicable Controllers	Cable Length	Options
WA: Battery-less Absolute	60: Servo motor 60W	16: 16mm 10: 10mm 5: 5mm 2.5: 2.5mm	50: 50mm 500: 500mm (50mm increments)	T2: SCON MSCON SSEL XSEL-P/Q XSEL-RA/SA	N : None P : 1m S : 3m M : 5m X <input type="checkbox"/> : Specified Length R <input type="checkbox"/> : Robot Cable	Refer to Options table below.		

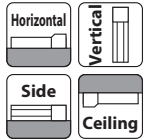

\* Depending on the model, there may be some limitations to using the vertical, side, and ceiling mount positions. Please refer to the Selection Notes on P.138 for more information.

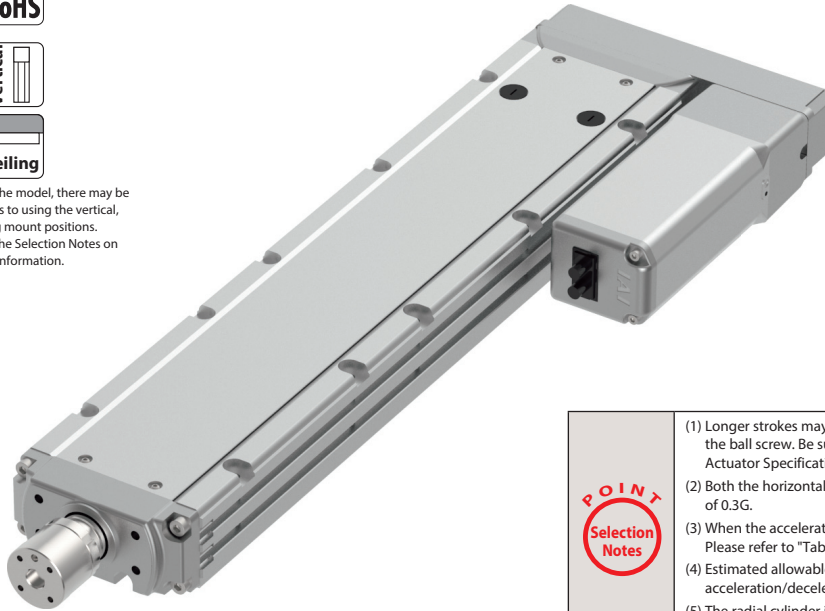

- POINT Selection Notes**
- (1) Longer strokes may cause the maximum speed to decrease due to resonance of the ball screw. Be sure to check the maximum speed of the desired stroke in the Actuator Specifications table, which can be found below.
  - (2) Both the horizontal and vertical payloads assume operation at an acceleration of 0.3G.
  - (3) When the acceleration is increased, the payload will be reduced. Please refer to "Table of Payload by Acceleration" on P.139 for more details.
  - (4) Estimated allowable duty varies depending on operating conditions (payload, acceleration/deceleration, etc.). Please refer to P.149 for more information.
  - (5) The radial cylinder is equipped with a built-in guide. Please refer to the graphs shown on P.147 and after for the allowable load mass.

## Actuator Specifications

### Lead and Payload

Model Number	Motor wattage (W)	Lead (mm)	Max. payload		Rated thrust (N)	Stroke (mm)
			Horizontal (kg)	Vertical (kg)		
RCS4-WRA10R-WA-60-16-①-T2-②-③	60	16	5	—	53	50~500 (50mm increments)
RCS4-WRA10R-WA-60-10-①-T2-②-③		10	13	2.5	85	
RCS4-WRA10R-WA-60-5-①-T2-②-③		5	25	5	170	
RCS4-WRA10R-WA-60-2.5-①-T2-②-③		2.5	40	10	340	

Legend: ① Stroke ② Cable Length ③ Option

### Stroke and Max Speed

(Unit: mm/s)

Lead	Stroke	Max Speed		
		50~400 (50mm increments)	450 (mm)	500 (mm)
16	—	800	—	770
10	—	600	580	490
5	—	300	290	240
2.5	—	150	145	120

### ① Stroke

① Stroke (mm)	RCS4-WRA10R	① Stroke (mm)	RCS4-WRA10R
50	○	300	○
100	○	350	○
150	○	400	○
200	○	450	○
250	○	500	○

### ② Cable Length

Type	Cable Code
Standard	P(1m)
	S(3m)
	M(5m)
Specified length (Standard cable)	X06(6m) ~ X10(10m)
	X11(11m) ~ X15(15m)
	X16(16m) ~ X20(20m)
Robot cable	R01(1m) ~ R03(3m)
	R04(4m) ~ R05(5m)
	R06(6m) ~ R10(10m)
	R11(11m) ~ R15(15m)
	R16(16m) ~ R20(20m)
	R20(20m)

### ③ Options

Name	Option Code	Reference Page
Brake	<b>B</b>	See P.131
Cable exit direction (Top)	<b>CJT</b>	See P.131
Cable exit direction (Bottom)	<b>CJB</b>	See P.131
Cable exit direction (Outside)	<b>CJO</b>	See P.131
Flange	<b>FL</b>	See P.132
Motor side-mounted to left (standard)	<b>ML</b>	See P.135
Motor side-mounted to right	<b>MR</b>	See P.135
Non-motor end specification	<b>NM</b>	See P.136
T-slot nut bar (Left)	<b>NTBL</b>	See P.136
T-slot nut bar (Right)	<b>NTBR</b>	See P.136

### Actuator Specifications

Item	Description
Drive system	Ball screw φ8mm, rolled C10
Positioning repeatability	±0.01mm
Lost motion	0.1mm or less
Rod	φ25mm Stainless steel
Rod non-rotation precision	0 degrees
Allowable load and torque on rod tip	Please see P. 84
Rod tip overhang distance	100mm or less
Ambient operating temp. & humidity	0~40°C, 85% RH or less (Non-condensing)

\* Be sure to confirm with the "Selection Notes (P.138)" when selecting options.



# RCS4-WRA12R

Battery-less Absolute

Motor Unit Type

Side-mounted Motor

Body Width **120** mm

**200v** AC Servo Motor

Model Specification Items	<b>RCS4</b> — <b>WRA12R</b> — <b>WA</b> — <b>100</b> — <input type="checkbox"/> — <input type="checkbox"/> — <b>T2</b> — <input type="checkbox"/> — <input type="checkbox"/>	* Body width does not include the width of the side-mounted motor.						
Series	Type	Encoder Type	Motor Type	Lead	Stroke	Applicable Controllers	Cable Length	Options
WA: Battery-less Absolute	100: Servo motor 100W	20:20mm 12:12mm 6: 6mm 3: 3mm	50:50mm 500:500mm (50mm increments)	T2:SCON MSCON SSEL XSEL-P/Q XSEL-RA/SA	N : None P : 1m S : 3m M : 5m X <input type="checkbox"/> : Specified Length R <input type="checkbox"/> : Robot Cable	Refer to Options table below.		

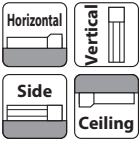

\* Depending on the model, there may be some limitations to using the vertical, side, and ceiling mount positions. Please refer to the Selection Notes on P.138 for more information.

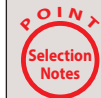
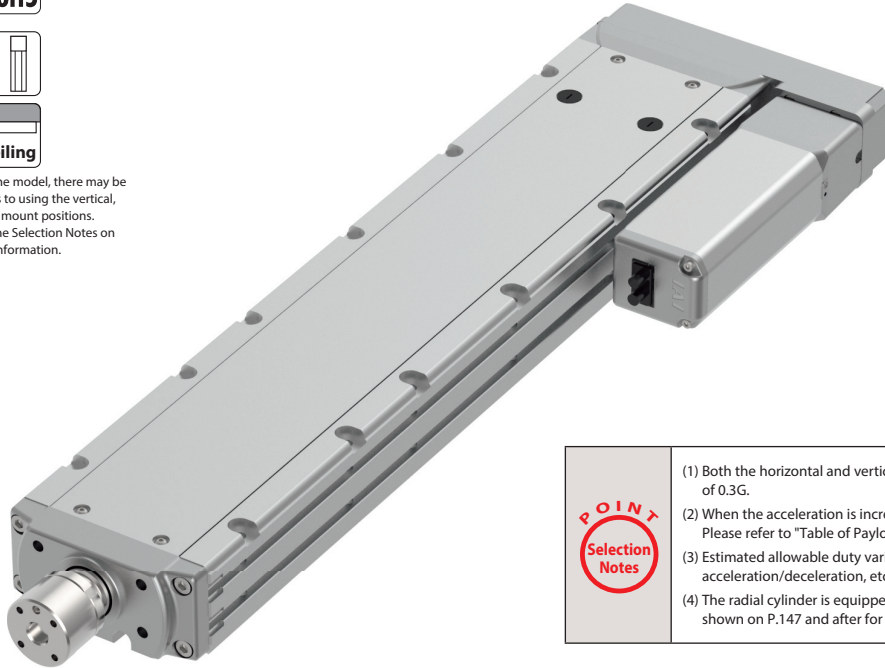

- (1) Both the horizontal and vertical payloads assume operation at an acceleration of 0.3G.
- (2) When the acceleration is increased, the payload will be reduced. Please refer to "Table of Payload by Acceleration" on P.139 for more details.
- (3) Estimated allowable duty varies depending on operating conditions (payload, acceleration/deceleration, etc.). Please refer to P. 149 for more information.
- (4) The radial cylinder is equipped with a built-in guide. Please refer to the graphs shown on P.147 and after for the allowable load mass.

## Actuator Specifications

### Lead and Payload

Model Number	Motor wattage (W)	Lead (mm)	Max. payload		Rated thrust (N)	Stroke (mm)
			Horizontal (kg)	Vertical (kg)		
RCS4-WRA12R-WA-100-20-①-T2-②-③	100	20	12	2	85	50~500 (50mm increments)
RCS4-WRA12R-WA-100-12-①-T2-②-③		12	25	6	142	
RCS4-WRA12R-WA-100-6-①-T2-②-③		6	40	15	283	
RCS4-WRA12R-WA-100-3-①-T2-②-③		3	60	20	566	

Legend: ① Stroke ② Cable Length ③ Option

### Stroke and Max Speed (Unit: mm/s)

Lead	Stroke	50~500
		(50mm increments)
20		1000
12		720
6		360
3		180

### ① Stroke

① Stroke (mm)	RCS4-WRA12R	① Stroke (mm)	RCS4-WRA12R
50	○	300	○
100	○	350	○
150	○	400	○
200	○	450	○
250	○	500	○

### ② Cable Length

Type	Cable Code
Standard	P(1m)
	S(3m)
	M(5m)
Specified length (Standard cable)	X06(6m) ~X10(10m)
	X11(11m)~X15(15m)
	X16(16m)~X20(20m)
Robot cable	R01(1m) ~R03(3m)
	R04(4m) ~R05(5m)
	R06(6m) ~R10(10m)
	R11(11m)~R15(15m)
	R16(16m)~R20(20m)

### ③ Options

Name	Option Code	Reference Page
Brake	<b>B</b>	See P.131
Cable exit direction (Top)	<b>CJT</b>	See P.131
Cable exit direction (Bottom)	<b>CJB</b>	See P.131
Cable exit direction (Outside)	<b>CJO</b>	See P.131
Flange	<b>FL</b>	See P.132
Motor side-mounted to left (standard)	<b>ML</b>	See P.135
Motor side-mounted to right	<b>MR</b>	See P.135
Non-motor end specification	<b>NM</b>	See P.136
T-slot nut bar (Left)	<b>NTBL</b>	See P.136
T-slot nut bar (Right)	<b>NTBR</b>	See P.136

### Actuator Specifications

Item	Description
Drive system	Ball screw φ10mm, rolled C10
Positioning repeatability	±0.01mm
Lost motion	0.1mm or less
Rod	φ30mm Stainless steel
Rod non-rotation precision	0 degrees
Allowable load and torque on rod tip	Please see P. 86
Rod tip overhang distance	100mm or less
Ambient operating temp. & humidity	0~40°C, 85% RH or less (Non-condensing)

\* Be sure to confirm with the "Selection Notes (P.138)" when selecting options.

CAD drawings can be downloaded from our website.  
www.intelligentactuator.com



\*1 When the rod is returning to its home position, please be careful of interference from surrounding objects, as it will travel until it reaches the M.E.  
M.E: Mechanical end S.E: Stroke end

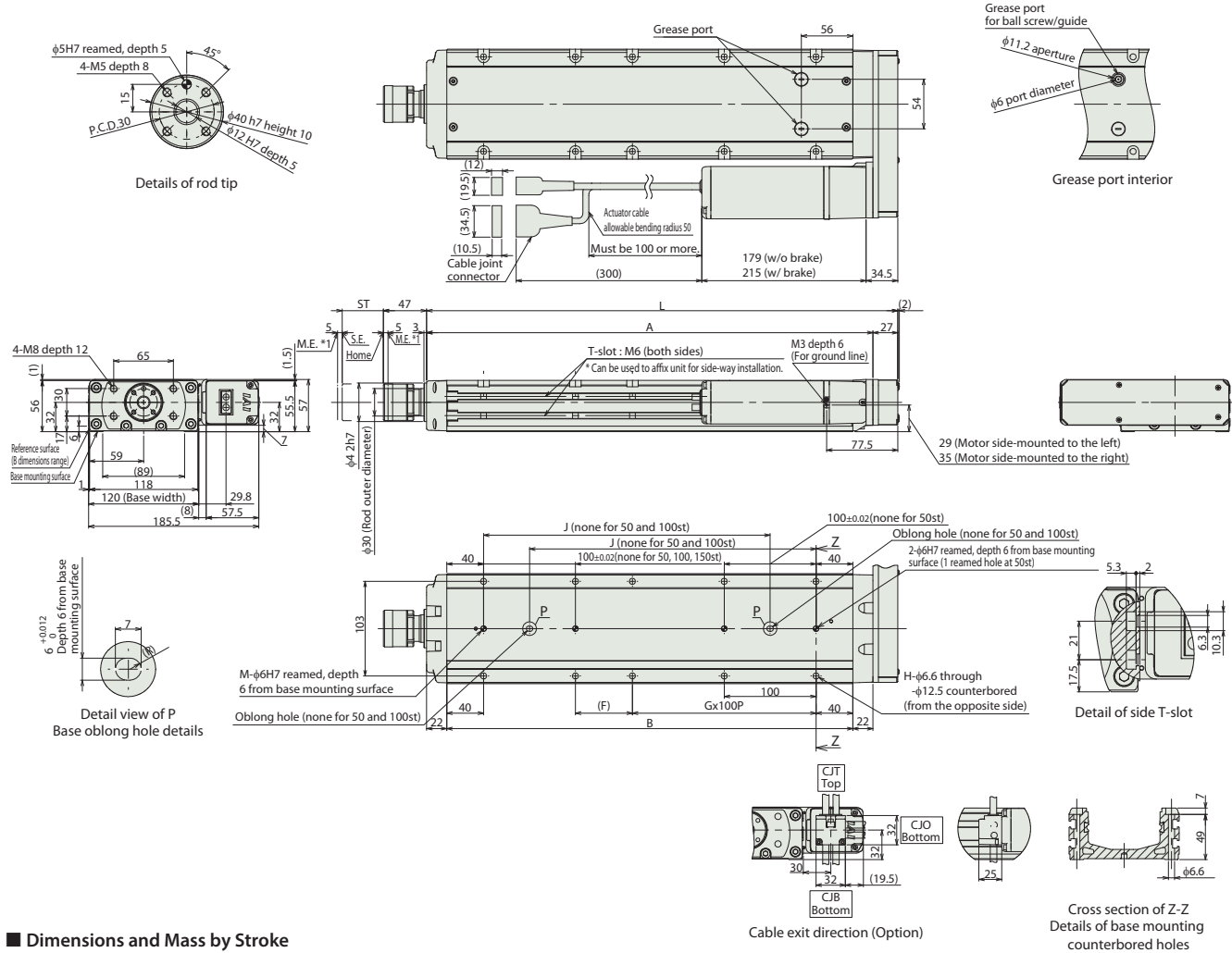

**■ Dimensions and Mass by Stroke**

	ST	50	100	150	200	250	300	350	400	450	500
L	263	313	363	413	463	513	563	613	663	713	
A	236	286	336	386	436	486	536	586	636	686	
B	192	242	292	342	392	442	492	542	592	642	
F	112	62	112	62	112	62	112	62	112	62	
G	0	1	1	1	1	2	2	3	3	4	
H	4	6	6	8	8	10	10	12	12	14	
J	-	-	162	212	262	312	362	412	462	512	
M	1	1	1	2	2	2	2	2	2	2	
Allowable static load on rod tip (N)	294	294	294	294	294	269	241	218	198	181	
Allowable static torque on rod tip (N·m)	20	20	20	20	20	20	20	20	20	20	
3000km	Allowable load on rod tip (N)	147	147	137	121	107	96	87	79	72	65
	Load offset 0mm	100	100	100	100	99	90	82	75	68	63
	Load offset 100mm	10.0	10.0	10.0	10.0	9.9	9.0	8.2	7.5	6.8	6.3
	Allowable dynamic torque on rod tip (N·m)	10.0	10.0	10.0	9.2	8.3	7.5	6.8	6.2	5.6	5.1
5000km	Allowable load on rod tip (N)	147	133	115	101	90	80	72	65	59	54
	Load offset 0mm	100	100	100	92	83	75	68	62	56	51
	Load offset 100mm	10.0	10.0	10.0	9.2	8.3	7.5	6.8	6.2	5.6	5.1
	Allowable dynamic torque on rod tip (N·m)	10.0	10.0	10.0	9.2	8.3	7.5	6.8	6.2	5.6	5.1
Mass (kg)	W/o brake	5.2	5.9	6.5	7.2	7.8	8.5	9.1	9.8	10.4	11.1
	W/ brake	5.5	6.2	6.8	7.5	8.1	8.8	9.4	10.1	10.7	11.4

**■ Rod Deflection of RCS4-WRA12R (Reference Values)**

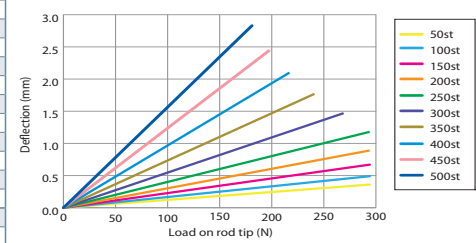

**Applicable Controllers**

The RCS4 series actuators can be operated by the controllers indicated below. Please select the type depending on your intended use.

Name	External view	Max. number of connectable axes	Input power	Control method				Maximum number of positioning points	Reference page	
				Positioner	Pulse train	Program	Network * Option			
SCON-CB/CGB		1	Single phase 100V/200VAC	●	●	-	<b>DeviceNet</b> <b>CC-Link</b> <b>PROFINET</b> <b>CompoNet</b> <b>MECHATROLINK</b> <b>EtherCAT</b> <b>EtherNet/IP</b>	512 (768 for network spec.)	Please contact IAI for more information.	
SCON-LC/LCG		1		-	-	●		512 (768 for network spec.)		
SCON-CAL/CGAL		1		●	-	-		512 (768 for network spec.)		
MSCON-C		6		This model is network-compatible only.				256		
SSEL-CS		2		●	-	●		20000		
XSEL-P/Q/RA/SA		8		Single phase 200VAC Three-phase 200VAC	-	-		●		55000 (Depending on the type)

Note: The type of compatible networks will vary depending on the controller. Please refer to the reference page for more information.

# RCS4-WRA14R

Battery-less Absolute

Motor Unit Type

Side-mounted Motor

Body Width **140\*** mm

**200v** AC Servo Motor

Model Specification Items	<b>RCS4</b> — <b>WRA14R</b> — <b>WA</b> — <b>200</b> — <input type="checkbox"/> — <input type="checkbox"/> — <b>T2</b> — <input type="checkbox"/> — <input type="checkbox"/>	* Body width does not include the width of the side-mounted motor.						
Series	Type	Encoder Type	Motor Type	Lead	Stroke	Applicable Controllers	Cable Length	Options
WA: Battery-less Absolute	200: Servo motor 200W	24:24mm 16:16mm 8: 8mm 4: 4mm	50:50mm 600:600mm (50mm increments)	T2:SCON MSCON SSEL XSEL-P/Q XSEL-RA/SA	N : None P : 1m S : 3m M : 5m X <input type="checkbox"/> : Specified Length R <input type="checkbox"/> : Robot Cable	Refer to Options table below.		

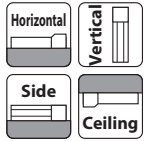

\* Depending on the model, there may be some limitations to using the vertical, side, and ceiling mount positions. Please refer to the Selection Notes on P.138 for more information.

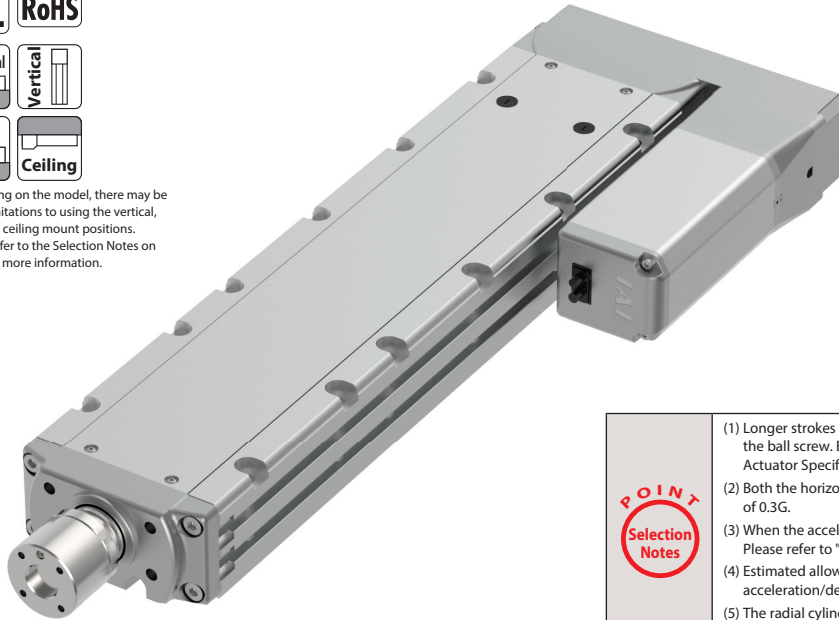

- POINT Selection Notes**
- (1) Longer strokes may cause the maximum speed to decrease due to resonance of the ball screw. Be sure to check the maximum speed of the desired stroke in the Actuator Specifications table, which can be found below.
  - (2) Both the horizontal and vertical payloads assume operation at an acceleration of 0.3G.
  - (3) When the acceleration is increased, the payload will be reduced. Please refer to "Table of Payload by Acceleration" on P.139 for more details.
  - (4) Estimated allowable duty varies depending on operating conditions (payload, acceleration/deceleration, etc.). Please refer to P.149 for more information.
  - (5) The radial cylinder is equipped with a built-in guide. Please refer to the graphs shown on P.147 and after for the allowable load mass.

## Actuator Specifications

### Lead and Payload

Model Number	Motor wattage (W)	Lead (mm)	Max. payload		Rated thrust (N)	Stroke (mm)
			Horizontal (kg)	Vertical (kg)		
RCS4-WRA14R-WA-200-24-①-T2-②-③	200	24	25	3	142	50~600 (50mm increments)
RCS4-WRA14R-WA-200-16-①-T2-②-③		16	50	8	214	
RCS4-WRA14R-WA-200-8-①-T2-②-③		8	65	20	427	
RCS4-WRA14R-WA-200-4-①-T2-②-③		4	85	30	855	

Legend: ① Stroke ② Cable Length ③ Option

### Stroke and Max Speed

(Unit: mm/s)

Lead	Stroke	50~600 (50mm increments)		
		550 (mm)	600 (mm)	600 (mm)
24		1200		
16		800		
8		480	450	390
4		240	220	190

### ① Stroke

① Stroke (mm)	RCS4-WRA14R	① Stroke (mm)	RCS4-WRA14R
50	○	350	○
100	○	400	○
150	○	450	○
200	○	500	○
250	○	550	○
300	○	600	○

### ② Cable Length

Type	Cable Code
Standard	P(1m)
	S(3m)
	M(5m)
Specified length (Standard cable)	X06(6m) ~ X10(10m)
	X11(11m) ~ X15(15m)
	X16(16m) ~ X20(20m)
Robot cable	R01(1m) ~ R03(3m)
	R04(4m) ~ R05(5m)
	R06(6m) ~ R10(10m)
	R11(11m) ~ R15(15m)
	R16(16m) ~ R20(20m)

### ③ Options

Name	Option Code	Reference Page
Brake	<b>B</b>	See P.131
Cable exit direction (Top)	<b>CJT</b>	See P.131
Cable exit direction (Bottom)	<b>CJB</b>	See P.131
Cable exit direction (Outside)	<b>CJO</b>	See P.131
Flange	<b>FL</b>	See P.132
Motor side-mounted to left (standard)	<b>ML</b>	See P.135
Motor side-mounted to right	<b>MR</b>	See P.135
Non-motor end specification	<b>NM</b>	See P.136
T-slot nut bar (Left)	<b>NTBL</b>	See P.136
T-slot nut bar (Right)	<b>NTBR</b>	See P.136

### Actuator Specifications

Item	Description
Drive system	Ball screw φ12mm, rolled C10
Positioning repeatability	±0.01mm
Lost motion	0.1 or less
Rod	φ40mm Stainless steel
Rod non-rotation precision	0 degrees
Allowable load and torque on rod tip	Please see P. 88
Rod tip overhang distance	150mm or less
Ambient operating temp. & humidity	0~40°C, 85% RH or less (Non-condensing)

\* Be sure to confirm with the "Selection Notes (P.138)" when selecting options.





# RCS4-WRA16R

Battery-less Absolute

Motor Unit Type

Side-mounted Motor

Body Width 160\* mm

200v AC Servo Motor

Model Specification Items	<b>RCS4</b> — <b>WRA16R</b> — <b>WA</b> — <b>400</b> — <input type="checkbox"/> — <input type="checkbox"/> — <b>T2</b> — <input type="checkbox"/> — <input type="checkbox"/>	* Body width does not include the width of the side-mounted motor.						
Series	Type	Encoder Type	Motor Type	Lead	Stroke	Applicable Controllers	Cable Length	Options
WA: Battery-less Absolute	400: Servo motor 400W	30:30mm 20:20mm 10:10mm 5: 5mm	50:50mm 800:800mm (50mm increments)	T2:SCON SSEL XSEL-P/Q XSEL-RA/SA	N : None P : 1m S : 3m M : 5m	X <input type="checkbox"/> : Specified Length R <input type="checkbox"/> : Robot Cable	Refer to Options table below.	

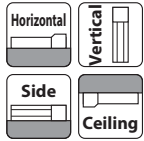

\* Depending on the model, there may be some limitations to using the vertical, side, and ceiling mount positions. Please refer to the Selection Notes on P.138 for more information.

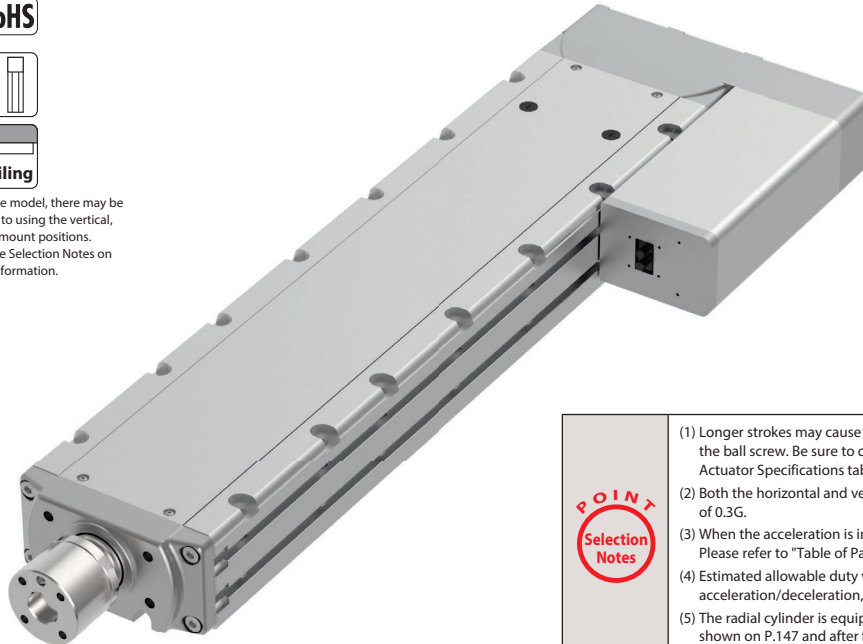

- POINT Selection Notes**
- (1) Longer strokes may cause the maximum speed to decrease due to resonance of the ball screw. Be sure to check the maximum speed of the desired stroke in the Actuator Specifications table, which can be found below.
  - (2) Both the horizontal and vertical payloads assume operation at an acceleration of 0.3G.
  - (3) When the acceleration is increased, the payload will be reduced. Please refer to "Table of Payload by Acceleration" on P.139 for more details.
  - (4) Estimated allowable duty varies depending on operating conditions (payload, acceleration/deceleration, etc.). Please refer to P. 149 for more information.
  - (5) The radial cylinder is equipped with a built-in guide. Please refer to the graphs shown on P.147 and after for the allowable load mass.

## Actuator Specifications

### Lead and Payload

Model Number	Motor wattage (W)	Lead (mm)	Max. payload		Rated thrust (N)	Stroke (mm)
			Horizontal (kg)	Vertical (kg)		
RCS4-WRA16R-WA-400-30-①-T2-②-③	400	30	30	6	226	50~800 (50mm increments)
RCS4-WRA16R-WA-400-20-①-T2-②-③		20	60	12	339	
RCS4-WRA16R-WA-400-10-①-T2-②-③		10	80	35	678	
RCS4-WRA16R-WA-400-5-①-T2-②-③		5	100	50	1357	

Legend: ① Stroke ② Cable Length ③ Option

### Stroke and Max Speed

(Unit: mm/s)

Stroke	Lead											
	50~250 (50mm increments)	300	350	400	450	500	550	600	650	700	750	800
30	1300	1050	860	710	600	510	440	390	340	300	270	
20	1000	880	700	570	470	400	340	295	260	225	200	180
10	500	430	340	280	230	195	165	145	125	110	100	90
5	250	210	170	130	115	95	80	70	60	55	50	45

### ① Stroke

① Stroke (mm)	RCS4-WRA16R	① Stroke (mm)	RCS4-WRA16R
50	○	450	○
100	○	500	○
150	○	550	○
200	○	600	○
250	○	650	○
300	○	700	○
350	○	750	○
400	○	800	○

### ② Cable Length

Type	Cable Code
Standard	P(1m)
	S(3m)
	M(5m)
Specified length (Standard cable)	X06(6m) ~ X10(10m)
	X11(11m) ~ X15(15m)
	X16(16m) ~ X20(20m)
Robot cable	R01(1m) ~ R03(3m)
	R04(4m) ~ R05(5m)
	R06(6m) ~ R10(10m)
	R11(11m) ~ R15(15m)
	R16(16m) ~ R20(20m)

### ③ Options

Name	Option Code	Reference Page
Brake	B	See P.131
Cable exit direction (Top)	CJT	See P.131
Cable exit direction (Bottom)	CJB	See P.131
Cable exit direction (Outside)	CJO	See P.131
Flange	FL	See P.132
Motor side-mounted to left (standard)	ML	See P.135
Motor side-mounted to right	MR	See P.135
Non-motor end specification	NM	See P.136
T-slot nut bar (Left)	NTBL	See P.136
T-slot nut bar (Right)	NTBR	See P.136

### Actuator Specifications

Item	Description
Drive system	Ball screw φ16mm, rolled C10
Positioning repeatability	±0.01mm
Lost motion	0.1mm or less
Rod	φ45mm Stainless steel
Rod non-rotation precision	0 degrees
Allowable load and torque on rod tip	Please see P. 90
Rod tip overhang distance	150mm or less
Ambient operating temp. & humidity	0~40°C, 85% RH or less (Non-condensing)

\* Be sure to confirm with the "Selection Notes (P.138)" when selecting options.



# RCS4-TA4C

<Single Block Specification>

Battery-less Absolute

Motor Unit Type

Coupled Motor

Body Width 40 mm

200v AC Servo Motor

Model Specification Items	<b>RCS4</b> — <b>TA4C</b> — <b>WA</b> — <b>60</b> — <input type="checkbox"/> — <input type="checkbox"/> — <b>T2</b> — <input type="checkbox"/> — <input type="checkbox"/>
	Series — Type — Encoder Type — Motor Type — Lead — Stroke — Applicable Controllers — Cable Length — Options
	WA: Battery-less Absolute      60: Servo motor 60W      16: 16mm 10: 10mm 5: 5mm 2.5: 2.5mm      25: 25mm 150: 150mm (25mm increments)      T2: SCON MSCON SSEL XSEL-P/Q XSEL-RA/SA      N : None P : 1m S : 3m M : 5m      Refer to Options table below. X <input type="checkbox"/> : Specified Length R <input type="checkbox"/> : Robot Cable

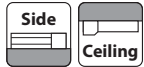

\* Depending on the model, there may be some limitations to using the vertical, side, and ceiling mount positions. Please refer to the Selection Notes on P.138 for more information.



**POINT Selection Notes**

- Both the horizontal and vertical payloads assume operation at an acceleration of 0.3G.
- When the acceleration is increased, the payload will be reduced. Please refer to "Table of Payload by Acceleration" on P.139 for more details.
- Estimated allowable duty varies depending on operating conditions (payload, acceleration/deceleration, etc.). Please refer to P.149 for more information.
- Please refer to the graphs shown on P.148 for the allowable load mass.

## Actuator Specifications

### Lead and Payload

Model Number	Motor wattage (W)	Lead (mm)	Max. payload		Rated thrust (N)	Stroke (mm)
			Horizontal (kg)	Vertical (kg)		
RCS4-TA4C-WA-60-16-①-T2-②-③	60	16	4	1.5	53	25~150 (25mm increments)
RCS4-TA4C-WA-60-10-①-T2-②-③		10	5	3	85	
RCS4-TA4C-WA-60-5-①-T2-②-③		5	5	6	170	
RCS4-TA4C-WA-60-2.5-①-T2-②-③		2.5	5	9	340	

Legend: ① Stroke ② Cable Length ③ Option

### Stroke and Max Speed (Unit: mm/s)

Lead	Stroke	25~150 (mm)
	16	
10		600
5		300
2.5		150

### ① Stroke

① Stroke (mm)	RCS4-TA4C	① Stroke (mm)	RCS4-TA4C
25	○	100	○
50	○	125	○
75	○	150	○

### ② Cable Length

Type	Cable Code
Standard	P(1m)
	S(3m)
	M(5m)
Specified length (Standard cable)	X06(6m) ~ X10(10m)
	X11(11m) ~ X15(15m)
	X16(16m) ~ X20(20m)
Robot cable	R01(1m) ~ R03(3m)
	R04(4m) ~ R05(5m)
	R06(6m) ~ R10(10m)
	R11(11m) ~ R15(15m)
	R16(16m) ~ R20(20m)

### ③ Options

Name	Option Code	Reference Page
Brake	<b>B</b>	See P.131
Cable exit direction (Top)	<b>CJT</b>	See P.131
Cable exit direction (Right)	<b>CJR</b>	See P.131
Cable exit direction (Left)	<b>CJL</b>	See P.131
Cable exit direction (Bottom)	<b>CJB</b>	See P.131
Non-motor end specification	<b>NM</b>	See P.136

### Actuator Specifications

Item	Description
Drive system	Ball screw φ8mm, rolled C10
Positioning repeatability	±0.01mm
Lost motion	0.1mm or less
Base	Material: Aluminum with white alumite treatment
Allowable static moment	Ma direction 13N·m, Mb direction 18.6N·m, Mc direction 25.3N·m
Allowable dynamic moment (*1)	Ma direction 4.98N·m, Mb direction 7.11N·m, Mc direction 9.68N·m
Ambient operating temp. & humidity	0~40°C, 85% RH or less (Non-condensing)

(\*1) Assumes a standard rated life of 5,000km. The running life will vary depending on operation and installation conditions.

Please contact IAI America for details of the running life.

See page 146 for moment load directions.

If the moment loads in Ma/Mb/Mc are within the allowable ranges, there is no overhang length limit. Please refer to the instruction manual for the amount of displacement of the table.



# RCS4-TA4C <Double Block Specification>

Battery-less Absolute

Motor Unit Type

Coupled Motor

Body Width  
40 mm

200v AC Servo Motor

Model Specification Items	<b>RCS4</b> — <b>TA4C</b> — <b>WA</b> — <b>60</b> — [ ] — [ ] — <b>T2</b> — [ ] — <b>DB</b> — [ ]
	Series — Type — Encoder Type — Motor Type — Lead — Stroke — Applicable Controllers — Cable Length — Options
	WA: Battery-less Absolute    60: Servo motor 60W    10: 10mm 5: 5mm 2.5: 2.5mm    40:40mm 240:240mm    T2:SCON MSCON SSEL XSEL-P/Q XSEL-RA/SA    N : None P : 1m S : 3m M : 5m X□□ : Specified Length R□□ : Robot Cable    Refer to Options table below.

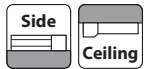

\* Depending on the model, there may be some limitations to using the vertical, side, and ceiling mount positions. Please refer to the Selection Notes on P.138 for more information.



**POINT Selection Notes**

- Both the horizontal and vertical payloads assume operation at an acceleration of 0.3G.
- When the acceleration is increased, the payload will be reduced. Please refer to "Table of Payload by Acceleration" on P.139 for more details.
- Estimated allowable duty varies depending on operating conditions (payload, acceleration/deceleration, etc.). Please refer to P. 149 for more information.
- Please refer to the graphs shown on P.148 for the allowable load mass.

## Actuator Specifications

### Lead and Payload

Model Number	Motor wattage (W)	Lead (mm)	Max. payload		Rated thrust (N)	Stroke (mm)
			Horizontal (kg)	Vertical (kg)		
RCS4-TA4C-WA-60-10-①-T2-②-DB-③	60	10	8	3	85	40~90 (25mm increments)
RCS4-TA4C-WA-60-5-①-T2-②-DB-③		5	10	6	170	140~240 (50mm increments)
RCS4-TA4C-WA-60-2.5-①-T2-②-DB-③		2.5	10	9	340	

Legend: ① Stroke ② Cable Length ③ Option

### Stroke and Max Speed (Unit: mm/s)

Lead	Stroke	40~240 (mm)
	10	
5		300
2.5		150

### ① Stroke

① Stroke (mm)	RCS4-TA4C	① Stroke (mm)	RCS4-TA4C
40	○	140	○
65	○	190	○
90	○	240	○

### ② Cable Length

Type	Cable Code
Standard	P(1m)
	S(3m)
	M(5m)
Specified length (Standard cable)	X06(6m) ~ X10(10m)
	X11(11m) ~ X15(15m)
	X16(16m) ~ X20(20m)
Robot cable	R01(1m) ~ R03(3m)
	R04(4m) ~ R05(5m)
	R06(6m) ~ R10(10m)
	R11(11m) ~ R15(15m)
	R16(16m) ~ R20(20m)

### ③ Options

Name	Option Code	Reference Page
Brake	<b>B</b>	See P.131
Cable exit direction (Top)	<b>CJT</b>	See P.131
Cable exit direction (Right)	<b>CJR</b>	See P.131
Cable exit direction (Left)	<b>CJL</b>	See P.131
Cable exit direction (Bottom)	<b>CJB</b>	See P.131
Non-motor end specification	<b>NM</b>	See P.136

### Actuator Specifications

Item	Description
Drive system	Ball screw φ8mm, rolled C10
Positioning repeatability	±0.01mm
Lost motion	0.1 mm or less
Base	Material: Aluminum with white alumite treatment
Allowable static moment	Ma direction 76.8N·m, Mb direction 110N·m, Mc direction 50.5N·m
Allowable dynamic moment (*1)	Ma direction 23.9N·m, Mb direction 34.1N·m, Mc direction 15.7N·m
Ambient operating temp. & humidity	0~40°C, 85% RH or less (Non-condensing)

(\*1) Assumes a standard rated life of 5,000km. The running life will vary depending on operation and installation conditions.

Please contact IAI America for details of the running life.

See page 146 for moment load directions.

If the moment loads in Ma/Mb/Mc are within the allowable ranges, there is no overhang length limit. Please refer to the instruction manual for the amount of displacement of the table.



\*1 When the table is returning to its home position, please be mindful of possible interference from surrounding objects, as it will travel until it reaches the M.E.  
M.E: Mechanical end S.E: Stroke end

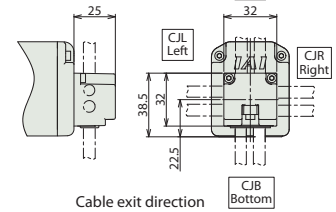
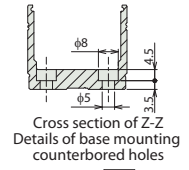
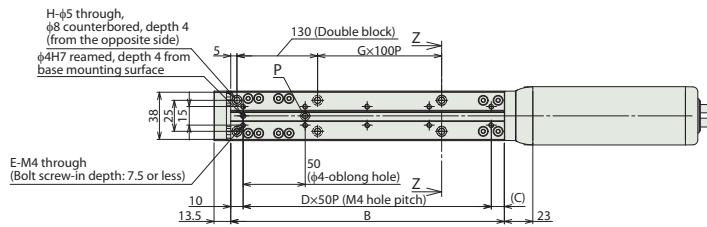
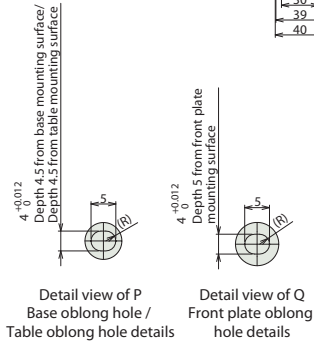
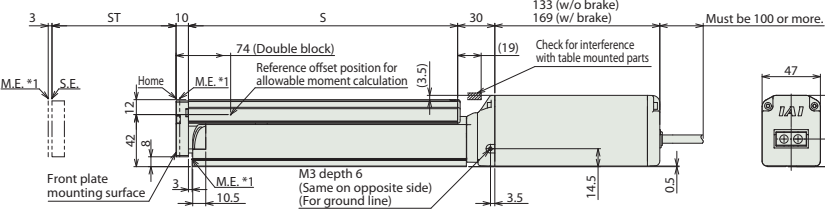
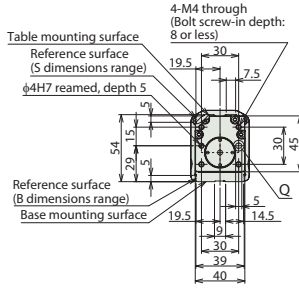
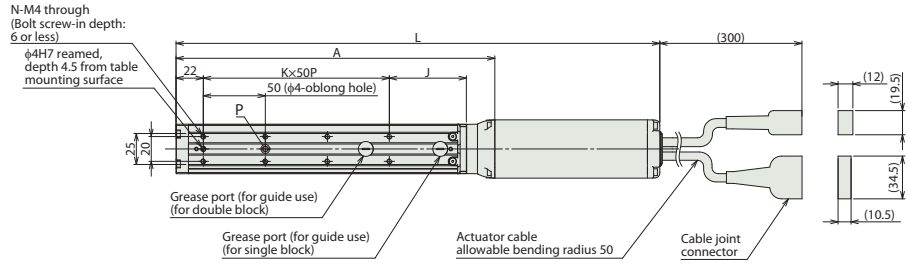
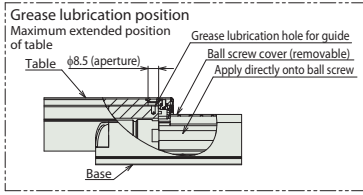

■ Dimensions and Mass by Stroke

	ST	40	65	90	140	190	240
L	W/o brake	340	365	390	440	490	540
	W/ brake	376	401	426	476	526	576
	A	207	232	257	307	357	407
	B	170.5	195.5	220.5	270.5	320.5	370.5
	C	10.5	35.5	10.5	10.5	10.5	10.5
	D	3	3	4	5	6	7
	E	8	8	10	12	14	16
	G	0	0	0	1	1	2
	H	4	4	4	6	6	8
	J	62	37	62	62	62	62
	K	2	3	3	4	5	6
	N	6	8	8	10	12	14
	S	167	192	217	267	317	367
Mass (kg)	W/o brake	1.6	1.7	1.8	2.0	2.1	2.3
	W/ brake	1.9	2.0	2.1	2.3	2.4	2.6

Applicable Controllers

The RCS4 series actuators can be operated by the controllers indicated below. Please select the type depending on your intended use.

Name	External view	Max. number of connectable axes	Input power	Control method				Maximum number of positioning points	Reference page	
				Positioner	Pulse train	Program	Network * Option			
SCON-CB/CGB		1	Single phase 100V/200VAC	●	●	—	DeviceNet CC-Link CC-Link IE CompoNet MECHATROLINK EtherCAT EtherNet/IP EtherNet/IP	512 (768 for network spec.)	Please contact IAI for more information.	
SCON-LC/LCG		1		—	—	●		512 (768 for network spec.)		
SCON-CAL/CGAL		1		●	—	—		512 (768 for network spec.)		
MSCON-C		6		This model is network-compatible only.				256		
SSEL-CS		2		●	—	●		20000		
XSEL-P/Q/RA/SA		8	Single phase 200VAC Three-phase 200VAC	—	—	●	55000 (Depending on the type)			

Note:  
The type of compatible networks will vary depending on the controller. Please refer to the reference page for more information.

# RCS4-TA6C <Single Block Specification>

Battery-less Absolute

Motor Unit Type

Coupled Motor

Body Width 60 mm

200v AC Servo Motor

Model Specification Items	<b>RCS4</b> — <b>TA6C</b> — <b>WA</b> — <b>100</b> — <input type="checkbox"/> — <input type="checkbox"/> — <b>T2</b> — <input type="checkbox"/> — <input type="checkbox"/>
	Series — Type — Encoder Type — Motor Type — Lead — Stroke — Applicable Controllers — Cable Length — Options
	WA: Battery-less Absolute    100: Servo motor 100W    20:20mm 12:12mm 6: 6mm 3: 3mm    25:25mm 200:200mm (25mm increments)    T2:SCON MSCON SSEL XSEL-P/Q XSEL-RA/SA    N : None P : 1m S : 3m M : 5m    Refer to Options table below. X <input type="checkbox"/> : Specified Length R <input type="checkbox"/> : Robot Cable

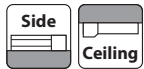

\* Depending on the model, there may be some limitations to using the vertical, side, and ceiling mount positions. Please refer to the Selection Notes on P.138 for more information.



**POINT Selection Notes**

- Both the horizontal and vertical payloads assume operation at an acceleration of 0.3G.
- When the acceleration is increased, the payload will be reduced. Please refer to "Table of Payload by Acceleration" on P.139 for more details.
- Estimated allowable duty varies depending on operating conditions (payload, acceleration/deceleration, etc.). Please refer to P.149 for more information.
- Please refer to the graphs shown on P.148 for the allowable load mass.

## Actuator Specifications

### Lead and Payload

Model Number	Motor wattage (W)	Lead (mm)	Max. payload		Rated thrust (N)	Stroke (mm)
			Horizontal (kg)	Vertical (kg)		
RCS4-TA6C-WA-100-20- <input type="checkbox"/> -T2- <input type="checkbox"/> - <input type="checkbox"/>	100	20	8	4	85	25~200 (25mm increments)
RCS4-TA6C-WA-100-12- <input type="checkbox"/> -T2- <input type="checkbox"/> - <input type="checkbox"/>		12	8	6	142	
RCS4-TA6C-WA-100-6- <input type="checkbox"/> -T2- <input type="checkbox"/> - <input type="checkbox"/>		6	8	10	283	
RCS4-TA6C-WA-100-3- <input type="checkbox"/> -T2- <input type="checkbox"/> - <input type="checkbox"/>		3	10	12	566	

Legend:  Stroke  Cable Length  Option

### Stroke and Max Speed (Unit: mm/s)

Lead	Stroke	25~200 (mm)
		20
12	720	
6	360	
3	180	

### ① Stroke

① Stroke (mm)	RCS4-TA6C	① Stroke (mm)	RCS4-TA6C
25	<input type="checkbox"/>	125	<input type="checkbox"/>
50	<input type="checkbox"/>	150	<input type="checkbox"/>
75	<input type="checkbox"/>	175	<input type="checkbox"/>
100	<input type="checkbox"/>	200	<input type="checkbox"/>

### ② Cable Length

Type	Cable Code
Standard	P(1m)
	S(3m)
	M(5m)
Specified length (Standard cable)	X06(6m) ~ X10(10m)
	X11(11m) ~ X15(15m)
	X16(16m) ~ X20(20m)
Robot cable	R01(1m) ~ R03(3m)
	R04(4m) ~ R05(5m)
	R06(6m) ~ R10(10m)
	R11(11m) ~ R15(15m)
	R16(16m) ~ R20(20m)
	R16(16m) ~ R20(20m)

### ③ Options

Name	Option Code	Reference Page
Brake	<b>B</b>	See P.131
Cable exit direction (Top)	<b>CJT</b>	See P.131
Cable exit direction (Right)	<b>CJR</b>	See P.131
Cable exit direction (Left)	<b>CJL</b>	See P.131
Cable exit direction (Bottom)	<b>CJB</b>	See P.131
Non-motor end specification	<b>NM</b>	See P.136

### Actuator Specifications

Item	Description
Drive system	Ball screw φ10mm, rolled C10
Positioning repeatability	±0.01mm
Lost motion	0.1 mm or less
Base	Material: Aluminum with white alumite treatment
Allowable static moment	Ma direction 32.3N·m, Mb direction 46.2N·m, Mc direction 68.3N·m
Allowable dynamic moment (*1)	Ma direction 11.6N·m, Mb direction 16.6N·m, Mc direction 24.6N·m
Ambient operating temp. & humidity	0~40°C, 85% RH or less (Non-condensing)

(\*1) Assumes a standard rated life of 5,000km. The running life will vary depending on operation and installation conditions.

Please contact IAI America for details of the running life.

See page 146 for moment load directions.

If the moment loads in Ma/Mb/Mc are within the allowable ranges, there is no overhang length limit. Please refer to the instruction manual for the amount of displacement of the table.



CAD drawings can be downloaded from our website.  
www.intelligentactuator.com



\*1 When the table is returning to its home position, please be mindful of possible interference from surrounding objects, as it will travel until it reaches the M.E.  
M.E: Mechanical end S.E: Stroke end

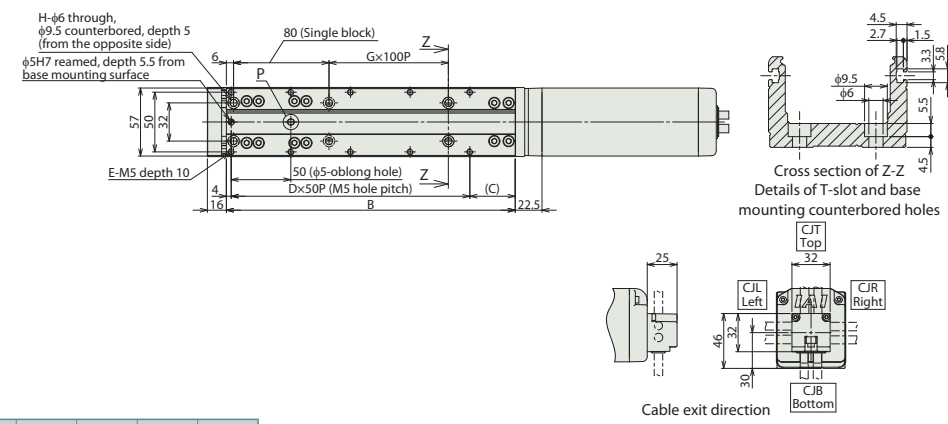
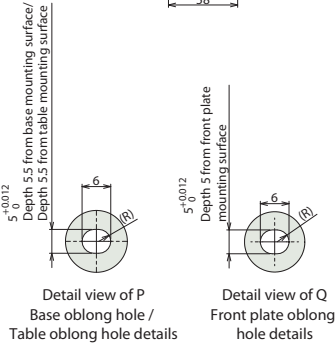
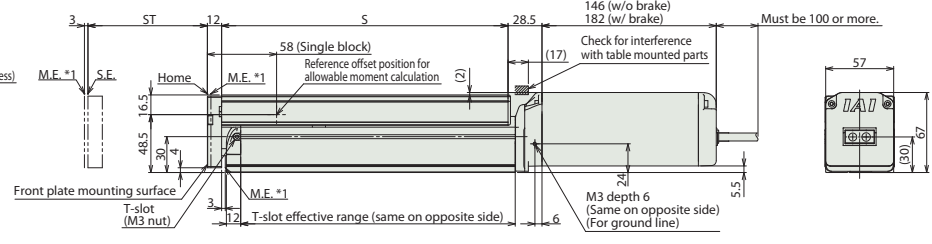
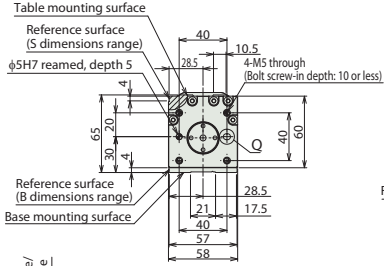
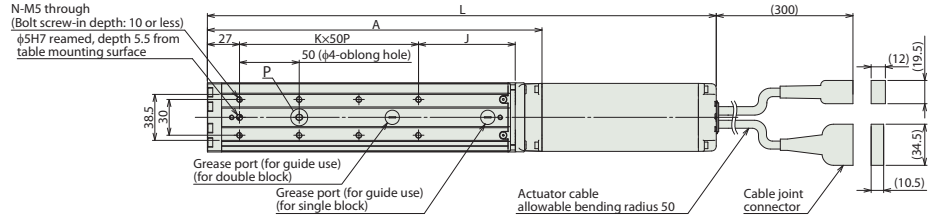
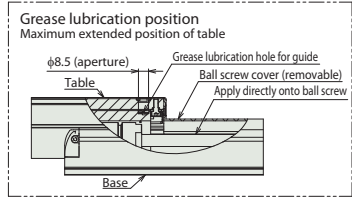

■ Dimensions and Mass by Stroke

L	ST	25	50	75	100	125	150	175	200
		W/o brake	301.5	326.5	351.5	376.5	401.5	426.5	451.5
	W/ brake	337.5	362.5	387.5	412.5	437.5	462.5	487.5	512.5
	A	155.5	180.5	205.5	230.5	255.5	280.5	305.5	330.5
	B	117	142	167	192	217	242	267	292
	C	13	38	13	38	13	38	13	38
	D	2	2	3	3	4	4	5	5
	E	6	6	8	8	10	10	12	12
	G	0	0	0	0	1	1	1	1
	H	4	4	4	4	6	6	6	6
	J	56	81	56	81	56	81	56	81
	K	1	1	2	2	3	3	4	4
	N	4	4	6	6	8	8	10	10
	S	115	140	165	190	215	240	265	290
Mass (kg)	W/o brake	2.1	2.3	2.4	2.6	2.7	2.9	3.1	3.2
	W/ brake	2.4	2.6	2.7	2.9	3.0	3.2	3.4	3.5

Applicable Controllers

The RCS4 series actuators can be operated by the controllers indicated below. Please select the type depending on your intended use.

Name	External view	Max. number of connectable axes	Input power	Control method				Maximum number of positioning points	Reference page	
				Positioner	Pulse train	Program	Network * Option			
SCON-CB/CGB		1	Single phase 100V/200VAC	●	●	—	DeviceNet CC-Link CANopen CompoNet MECHATROLINK EtherCAT EtherNet/IP	512 (768 for network spec.)	Please contact IAI for more information.	
SCON-LC/LCG		1		—	—	●		512 (768 for network spec.)		
SCON-CAL/CGAL		1		●	—	—		512 (768 for network spec.)		
MSCON-C		6		This model is network-compatible only.				256		
SSEL-CS		2		●	—	●		20000		
XSEL-P/Q/RA/SA		8	Single phase 200VAC Three-phase 200VAC	—	—	●	55000 (Depending on the type)			

Note: The type of compatible networks will vary depending on the controller. Please refer to the reference page for more information.

Foreword  
Slider Type  
Wide Slider Type  
Rod Type  
Radial Cylinder  
Wide Radial Cylinder  
Table Type  
Cleanroom Slider  
Cleanroom Wide Slider  
Options  
Reference Data  
Controller

# RCS4-TA6C <Double Block Specification>

Battery-less Absolute

Motor Unit Type

Coupled Motor

Body Width  
60 mm

200v AC Servo Motor

Model Specification Items	<b>RCS4</b>	<b>TA6C</b>	<b>WA</b>	<b>100</b>			<b>T2</b>		<b>DB</b>	
	Series	Type	Encoder Type	Motor Type	Lead	Stroke	Applicable Controllers	Cable Length	Options	
			WA: Battery-less Absolute	100: Servo Motor 100W	12:12mm 6: 6mm 3: 3mm	45:45mm 320:320mm	T2: SCON MSCON SSEL XSEL-P/Q XSEL-RA/SA	N : None P : 1m S : 3m M : 5m X□□ : Specified Length R□□ : Robot Cable	Refer to Options table below.	



\* Depending on the model, there may be some limitations to using the vertical, side, and ceiling mount positions. Please refer to the Selection Notes on P.138 for more information.



- POINT Selection Notes**
- (1) Longer strokes may cause the maximum speed to decrease due to resonance of the ball screw. Be sure to check the maximum speed of the desired stroke in the Actuator Specifications table, which can be found below.
  - (2) Both the horizontal and vertical payloads assume operation at an acceleration of 0.3G.
  - (3) When the acceleration is increased, the payload will be reduced. Please refer to "Table of Payload by Acceleration" on P.139 for more details.
  - (4) Estimated allowable duty varies depending on operating conditions (payload, acceleration/deceleration, etc.). Please refer to P. 149 for more information.
  - (5) Please refer to the graphs shown on P.148 for the allowable load mass.

## Actuator Specifications

### Lead and Payload

Model Number	Motor wattage (W)	Lead (mm)	Max. payload		Rated thrust (N)	Stroke (mm)
			Horizontal (kg)	Vertical (kg)		
RCS4-TA6C-WA-100-12-①-T2-②-DB-③	100	12	14	6	142	45~120 (25mm increments)
RCS4-TA6C-WA-100-6-①-T2-②-DB-③		6	20	10	283	170~320 (50mm increments)
RCS4-TA6C-WA-100-3-①-T2-②-DB-③		3	20	12	566	

Legend: ① Stroke ② Cable Length ③ Option

### Stroke and Max Speed (Unit: mm/s)

Lead	Stroke	45~270 (mm)	320 (mm)
		12	720
6	360	285	
3	180	140	

### ① Stroke

① Stroke (mm)	RCS4-TA6C	① Stroke (mm)	RCS4-TA6C
45	○	170	○
70	○	220	○
95	○	270	○
120	○	320	○

### ② Cable Length

Type	Cable Code
Standard	P(1m)
	S(3m)
	M(5m)
Specified length (Standard cable)	X06(6m) ~ X10(10m)
	X11(11m) ~ X15(15m)
	X16(16m) ~ X20(20m)
Robot cable	R01(1m) ~ R03(3m)
	R04(4m) ~ R05(5m)
	R06(6m) ~ R10(10m)
	R11(11m) ~ R15(15m)
	R16(16m) ~ R20(20m)

### ③ Options

Name	Option Code	Reference Page
Brake	<b>B</b>	See P.131
Cable exit direction (Top)	<b>CJT</b>	See P.131
Cable exit direction (Right)	<b>CJR</b>	See P.131
Cable exit direction (Left)	<b>CJL</b>	See P.131
Cable exit direction (Bottom)	<b>CJB</b>	See P.131
Non-motor end specification	<b>NM</b>	See P.136

### Actuator Specifications

Item	Description
Drive system	Ball screw φ10mm, rolled C10
Positioning repeatability	±0.01mm
Lost motion	0.1 mm or less
Base	Material: Aluminum with white alumite treatment
Allowable static moment	Ma direction 169N·m, Mb direction 242N·m, Mc direction 137N·m
Allowable dynamic moment (*1)	Ma direction 49.5N·m, Mb direction 70.7N·m, Mc direction 40N·m
Ambient operating temp. & humidity	0~40°C, 85% RH or less (Non-condensing)

(\*1) Assumes a standard rated life of 5,000km. The running life will vary depending on operation and installation conditions. Please contact IAI America for details of the running life. Please contact IAI America for more information regarding the directions of the allowable moment and overhang load length. Please refer to the instruction manual for the amount of displacement of the table.

CAD drawings can be downloaded from our website.  
www.intelligentactuator.com



\*1 When the table is returning to its home position, please be mindful of possible interference from surrounding objects, as it will travel until it reaches the M.E.  
M.E: Mechanical end S.E: Stroke end

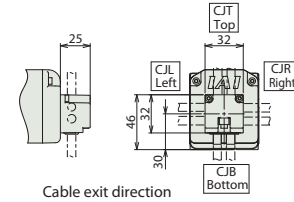
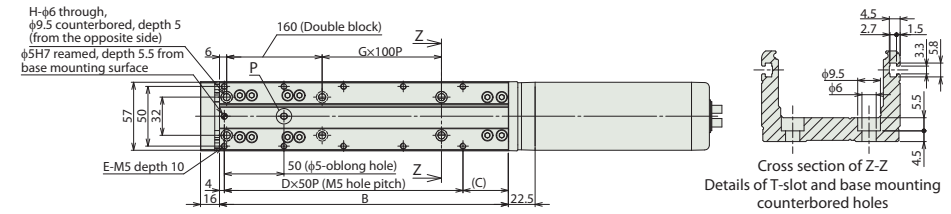
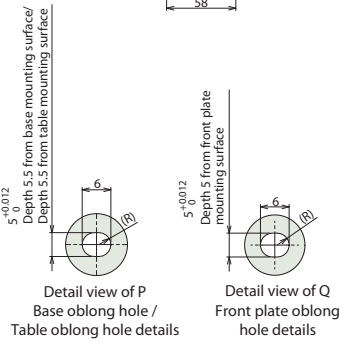
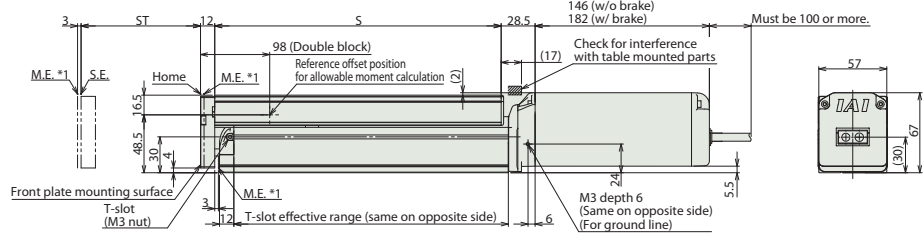
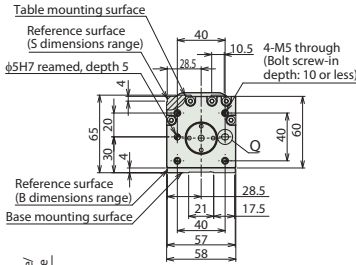
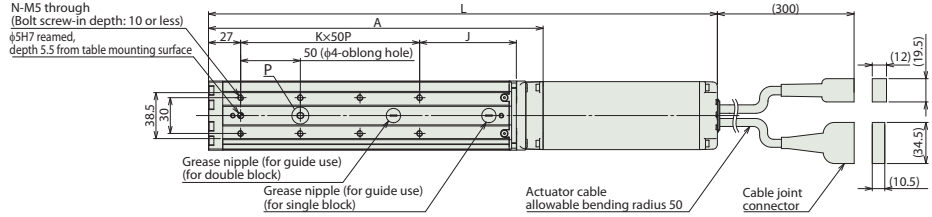
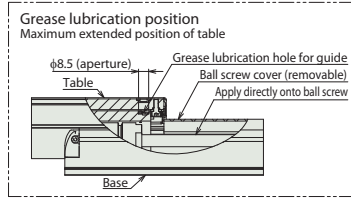

■ Dimensions and Mass by Stroke

L	ST	Stroke							
		45	70	95	120	170	220	270	320
W/o brake	401.5	426.5	451.5	476.5	526.5	576.5	626.5	676.5	
	437.5	462.5	487.5	512.5	562.5	612.5	662.5	712.5	
W/ brake	255.5	280.5	305.5	330.5	380.5	430.5	480.5	530.5	
A	217	242	267	292	342	392	442	492	
B	13	38	13	38	38	38	38	38	
C	4	4	5	5	6	7	8	9	
D	10	10	12	12	14	16	18	20	
E	0	0	0	0	1	1	2	2	
G	4	4	4	4	6	6	8	8	
H	56	81	56	81	81	81	81	81	
J	3	3	4	4	5	6	7	8	
K	8	8	10	10	12	14	16	18	
N	215	240	265	290	340	390	440	490	
S	2.9	3.1	3.3	3.4	3.7	4.1	4.4	4.7	
Mass (kg)	W/o brake	2.9	3.1	3.3	3.4	3.7	4.1	4.4	4.7
	W/ brake	3.2	3.4	3.6	3.7	4	4.4	4.7	5

Applicable Controllers

The RCS4 series actuators can be operated by the controllers indicated below. Please select the type depending on your intended use.

Name	External view	Max. number of connectable axes	Input power	Control method				Maximum number of positioning points	Reference page	
				Positioner	Pulse train	Program	Network * Option			
SCON-CB/CGB		1	Single phase 100V/200VAC	●	●	—	DeviceNet CC-Link CANopen CompoNet MECHATROLINK EtherCAT EtherNet/IP	512 (768 for network spec.)	Please contact IAI for more information.	
SCON-LC/LCG		1		—	—	●		512 (768 for network spec.)		
SCON-CAL/CGAL		1		●	—	—		512 (768 for network spec.)		
MSCON-C		6		This model is network-compatible only.				256		
SSEL-CS		2		●	—	●		20000		
XSEL-P/Q/RA/SA		8	Single phase 200VAC Three-phase 200VAC	—	—	●	55000 (Depending on the type)			

Note:  
The type of compatible networks will vary depending on the controller. Please refer to the reference page for more information.

Foreword  
Slider Type  
Wide Slider Type  
Rod Type  
Radial Cylinder  
Wide Radial Cylinder  
Table Type  
Cleanroom Slider  
Cleanroom Wide Slider  
Options  
Reference Data  
Controller

# RCS4-TA7C <Single Block Specification>

Battery-less Absolute

Motor Unit Type

Coupled Motor

Body Width 70 mm

200v AC Servo Motor

Model Specification Items	<b>RCS4</b> — <b>TA7C</b> — <b>WA</b> — <b>200</b> — <input type="checkbox"/> — <input type="checkbox"/> — <b>T2</b> — <input type="checkbox"/> — <input type="checkbox"/>							
Series	Type	Encoder Type	Motor Type	Lead	Stroke	Applicable Controllers	Cable Length	Options
		WA: Battery-less Absolute	200: Servo motor 200W	24:24mm 16:16mm 8: 8mm 4: 4mm	25:25mm 300:300mm	T2:SCON MSCON SSEL XSEL-P/Q XSEL-RA/SA	N : None P : 1m S : 3m M : 5m X <input type="checkbox"/> : Specified Length R <input type="checkbox"/> : Robot Cable	Refer to Options table below.

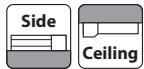

\* Depending on the model, there may be some limitations to using the vertical, side, and ceiling mount positions. Please refer to the Selection Notes on P.138 for more information.



**POINT Selection Notes**

- Both the horizontal and vertical payloads assume operation at an acceleration of 0.3G.
- When the acceleration is increased, the payload will be reduced. Please refer to "Table of Payload by Acceleration" on P.139 for more details.
- Estimated allowable duty varies depending on operating conditions (payload, acceleration/deceleration, etc.). Please refer to P. 149 for more information.
- Please refer to the graphs shown on P.148 for the allowable load mass.

## Actuator Specifications

### Lead and Payload

Model Number	Motor wattage (W)	Lead (mm)	Max. payload		Rated thrust (N)	Stroke (mm)
			Horizontal (kg)	Vertical (kg)		
RCS4-TA7C-WA-200-24-①-T2-②-③	200	24	12	5	142	25~200 (25mm increments) 250~300 (50mm increments)
RCS4-TA7C-WA-200-16-①-T2-②-③		16	15	10	214	
RCS4-TA7C-WA-200-8-①-T2-②-③		8	15	18	427	
RCS4-TA7C-WA-200-4-①-T2-②-③		4	15	20	855	

Legend: ① Stroke ② Cable Length ③ Option

### Stroke and Max Speed (Unit: mm/s)

Lead	Stroke	25~300 (mm)
24		1300
16		960
8		480
4		240

### ① Stroke

① Stroke (mm)	RCS4-TA7C	① Stroke (mm)	RCS4-TA7C
25	○	150	○
50	○	175	○
75	○	200	○
100	○	250	○
125	○	300	○

### ② Cable Length

Type	Cable Code
Standard	P(1m)
	S(3m)
	M(5m)
Specified length (Standard cable)	X06(6m) ~ X10(10m)
	X11(11m) ~ X15(15m)
	X16(16m) ~ X20(20m)
Robot cable	R01(1m) ~ R03(3m)
	R04(4m) ~ R05(5m)
	R06(6m) ~ R10(10m)
	R11(11m) ~ R15(15m)
	R16(16m) ~ R20(20m)

### ③ Options

Name	Option Code	Reference Page
Brake	<b>B</b>	See P.131
Cable exit direction (Top)	<b>CJT</b>	See P.131
Cable exit direction (Right)	<b>CJR</b>	See P.131
Cable exit direction (Left)	<b>CJL</b>	See P.131
Cable exit direction (Bottom)	<b>CJB</b>	See P.131
Non-motor end specification	<b>NM</b>	See P.136

### Actuator Specifications

Item	Description
Drive system	Ball screw φ12mm, rolled C10
Positioning repeatability	±0.01mm
Lost motion	0.1 mm or less
Base	Material: Aluminum with white alumite treatment
Allowable static moment	Ma direction 115N·m, Mb direction 115N·m, Mc direction 229N·m
Allowable dynamic moment (*1)	Ma direction 44.7N·m, Mb direction 44.7N·m, Mc direction 89.1N·m
Ambient operating temp. & humidity	0~40°C, 85% RH or less (Non-condensing)

(\*1) Assumes a standard rated life of 5,000km. The running life will vary depending on operation and installation conditions. Please contact IAI America for details of the running life. See page 146 for moment load directions. If the moment loads in Ma/Mb/Mc are within the allowable ranges, there is no overhang length limit. Please refer to the instruction manual for the amount of displacement of the table.

CAD drawings can be downloaded from our website.  
www.intelligentactuator.com



\*1 When the table is returning to its home position, please be mindful of possible interference from surrounding objects, as it will travel until it reaches the M.E.  
M.E: Mechanical end S.E: Stroke end

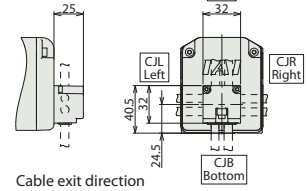
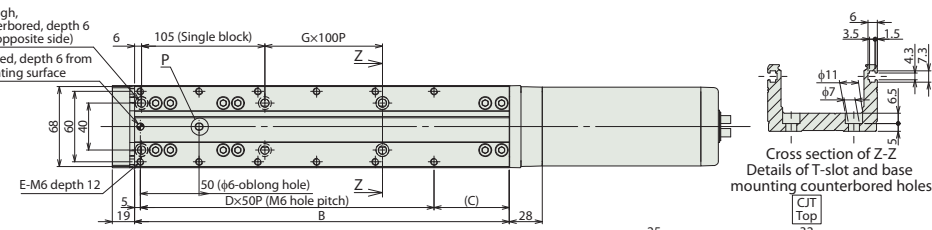
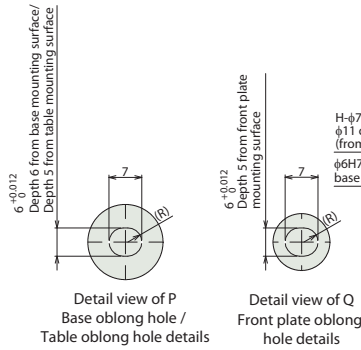
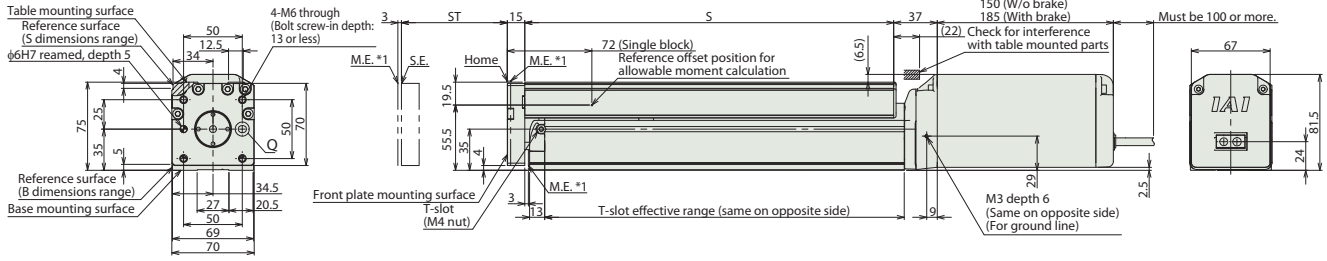
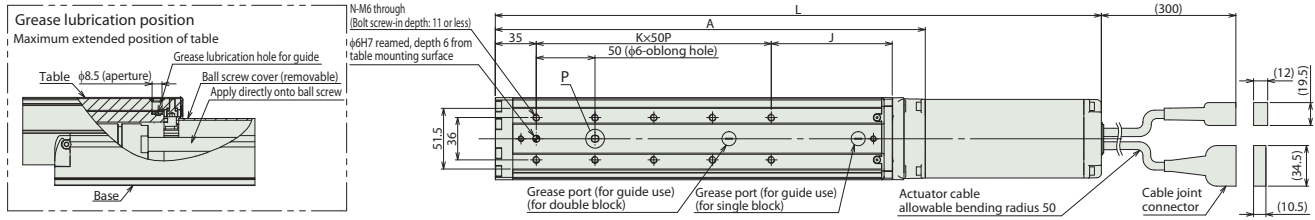

■ Dimensions and Mass by Stroke

L	ST	25	50	75	100	125	150	175	200	250	300
		W/o brake	341	366	391	416	441	466	491	516	566
	W/ brake	376	401	426	451	476	501	526	551	601	651
	A	191	216	241	266	291	316	341	366	416	466
	B	144	169	194	219	244	269	294	319	369	419
	C	39	64	39	64	39	64	39	64	64	64
	D	2	2	3	3	4	4	5	5	6	7
	E	6	6	8	8	10	10	12	12	14	16
	G	0	0	0	0	1	1	1	1	2	2
	H	4	4	4	4	6	6	6	6	8	8
	J	78	103	78	103	78	103	78	103	103	103
	K	1	1	2	2	3	3	4	4	5	6
	N	4	4	6	6	8	8	10	10	12	14
	S	139	164	189	214	239	264	289	314	364	414
Mass (kg)	W/o brake	3.8	4.0	4.2	4.5	4.7	4.9	5.1	5.4	5.8	6.3
	W/ brake	4.3	4.5	4.7	5.0	5.2	5.4	5.6	5.9	6.3	6.8

Applicable Controllers

The RCS4 series actuators can be operated by the controllers indicated below. Please select the type depending on your intended use.

Name	External view	Max. number of connectable axes	Input power	Control method				Maximum number of positioning points	Reference page	
				Positioner	Pulse train	Program	Network * Option			
SCON-CB/CGB		1	Single phase 100V/200VAC	●	●	—	DeviceNet CC-Link CompoNet MECHATROLINK EtherCAT EtherNet/IP	512 (768 for network spec.)	Please contact IAI for more information.	
SCON-LC/LCG		1		—	—	●		512 (768 for network spec.)		
SCON-CAL/CGAL		1		●	—	—		512 (768 for network spec.)		
MSCON-C		6		This model is network-compatible only.				256		
SSEL-CS		2		●	—	●		20000		
XSEL-P/Q/RA/SA		8	Single phase 200VAC Three-phase 200VAC	—	—	●	55000 (Depending on the type)			

Note:  
The type of compatible networks will vary depending on the controller. Please refer to the reference page for more information.

# RCS4-TA7C <Double Block Specification>

Battery-less Absolute

Motor Unit Type

Coupled Motor

Body Width 70 mm

200v AC Servo Motor

Model Specification Items	<b>RCS4</b> — <b>TA7C</b> — <b>WA</b> — <b>200</b> — <input type="checkbox"/> — <input type="checkbox"/> — <b>T2</b> — <input type="checkbox"/> — <b>DB</b> — <input type="checkbox"/>
	Series — Type — Encoder Type — Motor Type — Lead — Stroke — Applicable Controllers — Cable Length — Options
	WA: Battery-less Absolute      200: Servo motor 200W      16:16mm 8: 8mm 4: 4mm      40:40mm 390:390mm      T2:SCON MSCON SSEL XSEL-P/Q XSEL-RA/SA      N : None P : 1m S : 3m M : 5m X <input type="checkbox"/> : Specified Length R <input type="checkbox"/> : Robot Cable      Refer to Options table below.



\* Depending on the model, there may be some limitations to using the vertical, side, and ceiling mount positions. Please refer to the Selection Notes on P.138 for more information.



- POINT Selection Notes**
- (1) Longer strokes may cause the maximum speed to decrease due to resonance of the ball screw. Be sure to check the maximum speed of the desired stroke in the Actuator Specifications table, which can be found below.
  - (2) Both the horizontal and vertical payloads assume operation at an acceleration of 0.3G.
  - (3) When the acceleration is increased, the payload will be reduced. Please refer to "Table of Payload by Acceleration" on P.139 for more details.
  - (4) Estimated allowable duty varies depending on operating conditions (payload, acceleration/deceleration, etc.). Please refer to P. 149 for more information.
  - (5) Please refer to the graphs shown on P.148 for the allowable load mass.

## Actuator Specifications

### Lead and Payload

Model Number	Motor wattage (W)	Lead (mm)	Max. payload		Rated thrust (N)	Stroke (mm)
			Horizontal (kg)	Vertical (kg)		
RCS4-TA7C-WA-200-16-①-T2-②-DB-③	200	16	25	8	214	40~90 (25mm increments)
RCS4-TA7C-WA-200-8-①-T2-②-DB-③		8	30	18	427	140~390 (50mm increments)
RCS4-TA7C-WA-200-4-①-T2-②-DB-③		4	30	24	855	

Legend: ① Stroke ② Cable Length ③ Option

### Stroke and Max Speed

(Unit: mm/s)

Lead	Stroke	40~290 (mm)	
		340	390
16	16	960	600
8	8	480	300
4	4	240	150

### ① Stroke

① Stroke (mm)	RCS4-TA7C	① Stroke (mm)	RCS4-TA7C
40	○	240	○
65	○	290	○
90	○	340	○
140	○	390	○
190	○		

### ② Cable Length

Type	Cable Code
Standard	P(1m)
	S(3m)
	M(5m)
Specified length (Standard cable)	X06(6m) ~ X10(10m)
	X11(11m) ~ X15(15m)
	X16(16m) ~ X20(20m)
Robot cable	R01(1m) ~ R03(3m)
	R04(4m) ~ R05(5m)
	R06(6m) ~ R10(10m)
	R11(11m) ~ R15(15m)
	R16(16m) ~ R20(20m)

### ③ Options

Name	Option Code	Reference Page
Brake	<b>B</b>	See P.131
Cable exit direction (Top)	<b>CJT</b>	See P.131
Cable exit direction (Right)	<b>CJR</b>	See P.131
Cable exit direction (Left)	<b>CJL</b>	See P.131
Cable exit direction (Bottom)	<b>CJB</b>	See P.131
Non-motor end specification	<b>NM</b>	See P.136

### Actuator Specifications

Item	Description
Drive system	Ball screw φ12mm, rolled C10
Positioning repeatability	±0.01mm
Lost motion	0.1 mm or less
Base	Material: Aluminum with white alumite treatment
Allowable static moment	Ma direction 620N-m, Mb direction 620N-m, Mc direction 458N-m
Allowable dynamic moment (*1)	Ma direction 196N-m, Mb direction 196N-m, Mc direction 145N-m
Ambient operating temp. & humidity	0~40°C, 85% RH or less (Non-condensing)

(\*1) Assumes a standard rated life of 5,000km. The running life will vary depending on operation and installation conditions. Please contact IAI America for details of the running life. See page 146 for moment load directions. If the moment loads in Ma/Mb/Mc are within the allowable ranges, there is no overhang length limit. Please refer to the instruction manual for the amount of displacement of the table.



# RCS4-TA4R <Single Block Specification>

Battery-less Absolute

Motor Unit Type

Side-mounted Motor

Body Width 40\* mm

200v AC Servo Motor

Model Specification Items	<b>RCS4</b> — <b>TA4R</b> — <b>WA</b> — <b>60</b> — <input type="checkbox"/> — <input type="checkbox"/> — <b>T2</b> — <input type="checkbox"/> — <input type="checkbox"/>	* Body width does not include the width of the side-mounted motor.						
Series	Type	Encoder Type	Motor Type	Lead	Stroke	Applicable Controllers	Cable Length	Options
WA: Battery-less Absolute	60: Servo motor 60W	16: 16mm 10: 10mm 5: 5mm 2.5: 2.5mm	25: 25mm 150: 150mm (25mm increments)	T2: SCON MSCON SSEL XSEL-P/Q XSEL-RA/SA	N : None P : 1m S : 3m M : 5m X <input type="checkbox"/> : Specified Length R <input type="checkbox"/> : Robot Cable	Refer to Options table below.		

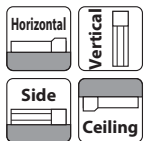

\* Depending on the model, there may be some limitations to using the vertical, side, and ceiling mount positions. Please refer to the Selection Notes on P.138 for more information.



**POINT Selection Notes**

- Both the horizontal and vertical payloads assume operation at an acceleration of 0.3G.
- When the acceleration is increased, the payload will be reduced. Please refer to "Table of Payload by Acceleration" on P.139 for more details.
- Estimated allowable duty varies depending on operating conditions (payload, acceleration/deceleration, etc.). Please refer to P.149 for more information.
- Please refer to the graphs shown on P.148 for the allowable load mass.

## Actuator Specifications

### Lead and Payload

Model Number	Motor wattage (W)	Lead (mm)	Max. payload		Rated thrust (N)	Stroke (mm)
			Horizontal (kg)	Vertical (kg)		
RCS4-TA4R-WA-60-16-①-T2-②-③	60	16	4	1.5	53	25~150 (25mm increments)
RCS4-TA4R-WA-60-10-①-T2-②-③		10	5	3	85	
RCS4-TA4R-WA-60-5-①-T2-②-③		5	5	6	170	
RCS4-TA4R-WA-60-2.5-①-T2-②-③		2.5	5	9	340	

Legend: ① Stroke ② Cable Length ③ Option

### Stroke and Max Speed (Unit: mm/s)

Lead	Stroke	25~150 (mm)
16		800
10		600
5		300
2.5		150

### ① Stroke

① Stroke (mm)	RCS4-TA4R	① Stroke (mm)	RCS4-TA4R
25	○	100	○
50	○	125	○
75	○	150	○

### ② Cable Length

Type	Cable Code
Standard	P(1m)
	S(3m)
	M(5m)
Specified length (Standard cable)	X06(6m) ~ X10(10m)
	X11(11m) ~ X15(15m)
	X16(16m) ~ X20(20m)
Robot cable	R01(1m) ~ R03(3m)
	R04(4m) ~ R05(5m)
	R06(6m) ~ R10(10m)
	R11(11m) ~ R15(15m)
	R16(16m) ~ R20(20m)

### ③ Options

Name	Option Code	Reference Page
Brake	<b>B</b>	See P.131
Cable exit direction (Top)	<b>CJT</b>	See P.131
Cable exit direction (Bottom)	<b>CJB</b>	See P.131
Cable exit direction (Outside)	<b>CJO</b>	See P.131
Motor side-mounted to left (standard)	<b>ML</b>	See P.135
Motor side-mounted to right	<b>MR</b>	See P.135
Non-motor end specification	<b>NM</b>	See P.136
Back mounting plate	<b>RP</b>	See P.137

### Actuator Specifications

Item	Description
Drive system	Ball screw φ8mm, rolled C10
Positioning repeatability	±0.01mm
Lost motion	0.1 mm or less
Base	Material: Aluminum with white alumite treatment
Allowable static moment	Ma direction 13N·m, Mb direction 18.6N·m, Mc direction 25.3N·m
Allowable dynamic moment (*1)	Ma direction 4.98N·m, Mb direction 7.11N·m, Mc direction 9.68N·m
Ambient operating temp. & humidity	0~40°C, 85% RH or less (Non-condensing)

(\*1) Assumes a standard rated life of 5,000km. The running life will vary depending on operation and installation conditions. Please contact IAI America for details of the running life. See page 146 for moment load directions. If the moment loads in Ma/Mb/Mc are within the allowable ranges, there is no overhang length limit. Please refer to the instruction manual for the amount of displacement of the table.





# RCS4-TA4R <Double Block Specification>

Battery-less Absolute

Motor Unit Type

Side-mounted Motor

Body Width 40\* mm

200v AC Servo Motor

Model Specification Items	<b>RCS4</b>	<b>TA4R</b>	<b>WA</b>	<b>60</b>			<b>T2</b>		<b>DB</b>		* Body width does not include the width of the side-mounted motor.
	Series	Type	Encoder Type	Motor Type	Lead	Stroke	Applicable Controllers	Cable Length	Options	Refer to Options table below.	
			WA: Battery-less Absolute	60: Servo motor 60W	10: 10mm 5: 5mm 2.5: 2.5mm	40: 40mm 240: 240mm	T2: SCON MSCON SSEL XSEL-P/Q XSEL-RA/SA	N: None P: 1m S: 3m M: 5m X□□: Specified Length R□□: Robot Cable			

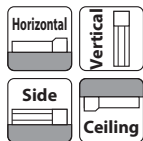

\* Depending on the model, there may be some limitations to using the vertical, side, and ceiling mount positions. Please refer to the Selection Notes on P.138 for more information.

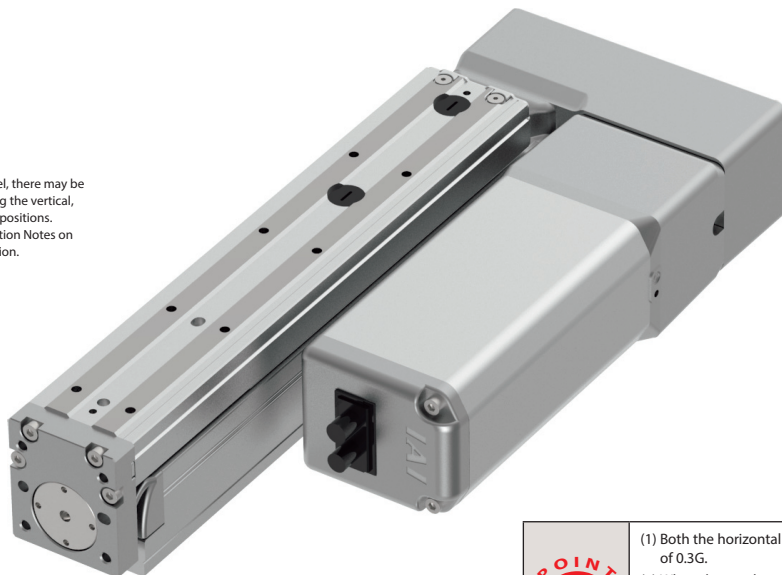

- POINT Selection Notes**
- Both the horizontal and vertical payloads assume operation at an acceleration of 0.3G.
  - When the acceleration is increased, the payload will be reduced. Please refer to "Table of Payload by Acceleration" on P.139 for more details.
  - Estimated allowable duty varies depending on operating conditions (payload, acceleration/deceleration, etc.). Please refer to P. 149 for more information.
  - Please refer to the graphs shown on P.148 for the allowable load mass.

## Actuator Specifications

### Lead and Payload

Model Number	Motor wattage (W)	Lead (mm)	Max. payload		Rated thrust (N)	Stroke (mm)
			Horizontal (kg)	Vertical (kg)		
RCS4-TA4R-WA-60-10-①-T2-②-DB-③	60	10	8	3	85	40~90 (25mm increments)
RCS4-TA4R-WA-60-5-①-T2-②-DB-③		5	10	6	170	140~240 (50mm increments)
RCS4-TA4R-WA-60-2.5-①-T2-②-DB-③		2.5	10	9	340	

Legend: ① Stroke ② Cable Length ③ Option

### Stroke and Max Speed (Unit: mm/s)

Lead	Stroke	40~240 (mm)
	10	
5		300
2.5		150

### ① Stroke

① Stroke (mm)	RCS4-TA4R	① Stroke (mm)	RCS4-TA4R
40	○	140	○
65	○	190	○
90	○	240	○

### ② Cable Length

Type	Cable Code
Standard	P(1m)
	S(3m)
	M(5m)
Specified length (Standard cable)	X06(6m) ~ X10(10m)
	X11(11m) ~ X15(15m)
	X16(16m) ~ X20(20m)
Robot cable	R01(1m) ~ R03(3m)
	R04(4m) ~ R05(5m)
	R06(6m) ~ R10(10m)
	R11(11m) ~ R15(15m)
	R16(16m) ~ R20(20m)

### ③ Options

Name	Option Code	Reference Page
Brake	<b>B</b>	See P.131
Cable exit direction (Top)	<b>CJT</b>	See P.131
Cable exit direction (Bottom)	<b>CJB</b>	See P.131
Cable exit direction (Outside)	<b>CJO</b>	See P.131
Motor side-mounted to left (standard)	<b>ML</b>	See P.135
Motor side-mounted to right	<b>MR</b>	See P.135
Non-motor end specification	<b>NM</b>	See P.136
Back mounting plate	<b>RP</b>	See P.137

### Actuator Specifications

Item	Description
Drive system	Ball screw φ8mm, rolled C10
Positioning repeatability	±0.01mm
Lost motion	0.1 mm or less
Base	Material: Aluminum with white alumite treatment
Allowable static moment	Ma direction 76.8N·m, Mb direction 110N·m, Mc direction 50.5N·m
Allowable dynamic moment (*1)	Ma direction 23.9N·m, Mb direction 34.1N·m, Mc direction 15.7N·m
Ambient operating temp. & humidity	0~40°C, 85% RH or less (Non-condensing)

(\*1) Assumes a standard rated life of 5,000km. The running life will vary depending on operation and installation conditions. Please contact IAI America for details of the running life.

See page 146 for moment load directions.

If the moment loads in Ma/Mb/Mc are within the allowable ranges, there is no overhang length limit. Please refer to the instruction manual for the amount of displacement of the table.

CAD drawings can be downloaded from our website.  
www.intelligentactuator.com



\*1 When the table is returning to its home position, please be mindful of possible interference from surrounding objects, as it will travel until it reaches the M.E.  
M.E: Mechanical end S.E: Stroke end

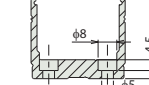
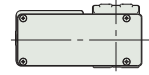
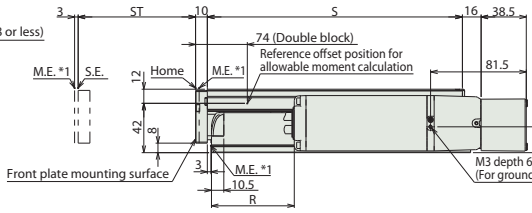
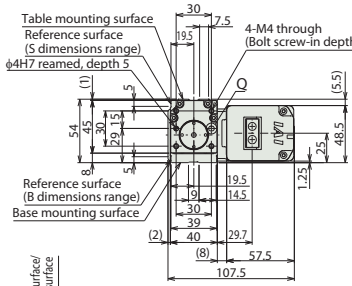
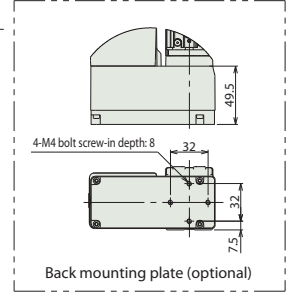
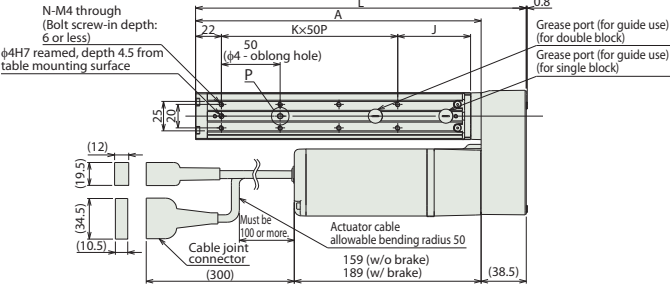
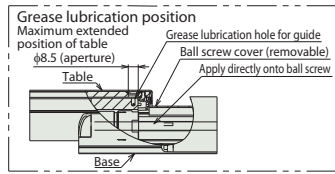

Cross section of Z-Z  
Details of base mounting counterbored holes

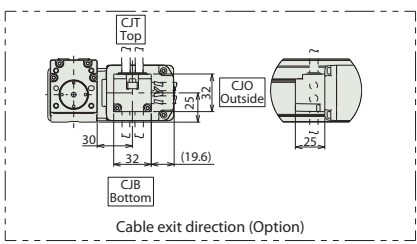
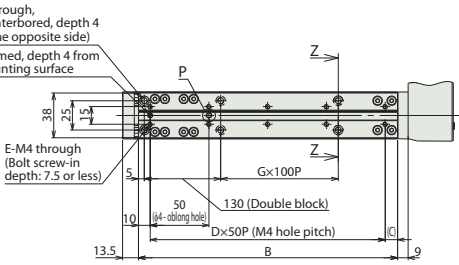
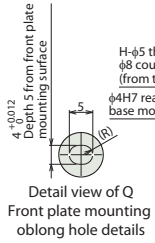
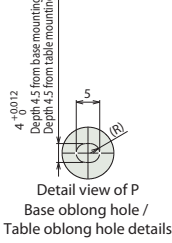

Dimensions and Mass by Stroke

ST	40	65	90	140	190	240	
L	231.5	256.5	281.5	331.5	381.5	431.5	
A	193	218	243	293	343	393	
B	170.5	195.5	220.5	270.5	320.5	370.5	
C	10.5	35.5	10.5	10.5	10.5	10.5	
D	3	3	4	5	6	7	
E	8	8	10	12	14	16	
G	0	0	0	1	1	2	
H	4	4	4	6	6	8	
J	62	37	62	62	62	62	
K	2	3	3	4	5	6	
N	6	8	8	10	12	14	
R (Note)	W/o brake	20.5	45.5	70.5	120.5	170.5	220.5
	W/ brake	-9.5	15.5	40.5	90.5	140.5	190.5
	S	167	192	217	267	317	367
Mass (kg)	W/o brake	1.9	2.0	2.1	2.3	2.4	2.6
	W/ brake	2.2	2.3	2.4	2.6	2.7	2.9

(Note) If the length for R is negative, the length of the actuator body is shorter than the motor unit.

Applicable Controllers

The RCS4 series actuators can be operated by the controllers indicated below. Please select the type depending on your intended use.

Name	External view	Max. number of connectable axes	Input power	Control method				Maximum number of positioning points	Reference page	
				Positioner	Pulse train	Program	Network * Option			
SCON-CB/CGB		1	Single phase 100V/200VAC	●	●	-	DeviceNet CC-Link CANopen CompoNet MECHATROLINK EtherCAT EtherNet/IP PROFINET	512 (768 for network spec.)	Please contact IAI for more information.	
SCON-LC/LCG		1		-	-	●		512 (768 for network spec.)		
SCON-CAL/CGAL		1		●	-	-		512 (768 for network spec.)		
MSCON-C		6		This model is network-compatible only.				256		
SSEL-CS		2		●	-	●		20000		
XSEL-P/Q/RA/SA		8	Single phase 200VAC Three-phase 200VAC	-	-	●	55000 (Depending on the type)			

Note:  
The type of compatible networks will vary depending on the controller. Please refer to the reference page for more information.

Foreword  
Slider Type  
Wide Slider Type  
Rod Type  
Radial Cylinder  
Wide Radial Cylinder  
Table Type  
Cleanroom Slider  
Cleanroom Wide Slider  
Options  
Reference Data  
Controller

# RCS4-TA6R <Single Block Specification>

Battery-less Absolute

Motor Unit Type

Side-mounted Motor

Body Width 60\* mm

200v AC Servo Motor

Model Specification Items	<b>RCS4</b> — <b>TA6R</b> — <b>WA</b> — <b>100</b> — <input type="checkbox"/> — <input type="checkbox"/> — <b>T2</b> — <input type="checkbox"/> — <input type="checkbox"/>	* Body width does not include the width of the side-mounted motor.						
Series	Type	Encoder Type	Motor Type	Lead	Stroke	Applicable Controllers	Cable Length	Options
WA: Battery-less Absolute	100: Servo motor 100W	20:20mm 12:12mm 6: 6mm 3: 3mm	25:25mm 200:200mm (25mm increments)	T2:SCON MSCON SSEL XSEL-P/Q XSEL-RA/SA	N : None P : 1m S : 3m M : 5m X <input type="checkbox"/> : Specified Length R <input type="checkbox"/> : Robot Cable	Refer to Options table below.		

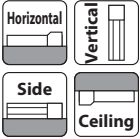

\* Depending on the model, there may be some limitations to using the vertical, side, and ceiling mount positions. Please refer to the Selection Notes on P.138 for more information.



**POINT Selection Notes**

- Both the horizontal and vertical payloads assume operation at an acceleration of 0.3G.
- When the acceleration is increased, the payload will be reduced. Please refer to "Table of Payload by Acceleration" on P.139 for more details.
- Estimated allowable duty varies depending on operating conditions (payload, acceleration/deceleration, etc.). Please refer to P. 149 for more information.
- Please refer to the graphs shown on P.148 for the allowable load mass.

## Actuator Specifications

### Lead and Payload

Model Number	Motor wattage (W)	Lead (mm)	Max. payload		Rated thrust (N)	Stroke (mm)
			Horizontal (kg)	Vertical (kg)		
RCS4-TA6R-WA-100-20- <input type="checkbox"/> -T2- <input type="checkbox"/> - <input type="checkbox"/>	100	20	8	4	85	25~200 (25mm increments)
RCS4-TA6R-WA-100-12- <input type="checkbox"/> -T2- <input type="checkbox"/> - <input type="checkbox"/>		12	8	6	142	
RCS4-TA6R-WA-100-6- <input type="checkbox"/> -T2- <input type="checkbox"/> - <input type="checkbox"/>		6	8	10	283	
RCS4-TA6R-WA-100-3- <input type="checkbox"/> -T2- <input type="checkbox"/> - <input type="checkbox"/>		3	10	10	566	

Legend:  Stroke  Cable Length  Option

### Stroke and Max Speed (Unit: mm/s)

Lead	Stroke	25~200 (mm)
20		1000
12		720
6		360
3		180

### ① Stroke

① Stroke (mm)	RCS4-TA6R	① Stroke (mm)	RCS4-TA6R
25	<input type="checkbox"/>	125	<input type="checkbox"/>
50	<input type="checkbox"/>	150	<input type="checkbox"/>
75	<input type="checkbox"/>	175	<input type="checkbox"/>
100	<input type="checkbox"/>	200	<input type="checkbox"/>

### ② Cable Length

Type	Cable Code
Standard	P(1m)
	S(3m)
	M(5m)
Specified length (Standard cable)	X06(6m) ~ X10(10m)
	X11(11m) ~ X15(15m)
	X16(16m) ~ X20(20m)
Robot cable	R01(1m) ~ R03(3m)
	R04(4m) ~ R05(5m)
	R06(6m) ~ R10(10m)
	R11(11m) ~ R15(15m)
	R16(16m) ~ R20(20m)
	R16(16m) ~ R20(20m)

### ③ Options

Name	Option Code	Reference Page
Brake	<b>B</b>	See P.131
Cable exit direction (Top)	<b>CJT</b>	See P.131
Cable exit direction (Bottom)	<b>CJB</b>	See P.131
Cable exit direction (Outside)	<b>CJO</b>	See P.131
Motor side-mounted to left (standard)	<b>ML</b>	See P.135
Motor side-mounted to right	<b>MR</b>	See P.135
Non-motor end specification	<b>NM</b>	See P.136

### Actuator Specifications

Item	Description
Drive system	Ball screw φ10mm, rolled C10
Positioning repeatability	±0.01mm
Lost motion	0.1 mm or less
Base	Material: Aluminum with white alumite treatment
Allowable static moment	Ma direction 32.3N·m, Mb direction 46.2N·m, Mc direction 68.3N·m
Allowable dynamic moment (*1)	Ma direction 11.6N·m, Mb direction 16.6N·m, Mc direction 24.6N·m
Ambient operating temp. & humidity	0~40°C, 85% RH or less (Non-condensing)

(\*1) Assumes a standard rated life of 5,000km. The running life will vary depending on operation and installation conditions. Please contact IAI America for details of the running life. See page 146 for moment load directions. If the moment loads in Ma/Mb/Mc are within the allowable ranges, there is no overhang length limit. Please refer to the instruction manual for the amount of displacement of the table.

CAD drawings can be downloaded from our website.  
www.intelligentactuator.com



\*1 When the table is returning to its home position, please be mindful of possible interference from surrounding objects, as it will travel until it reaches the M.E.  
M.E: Mechanical end S.E: Stroke end

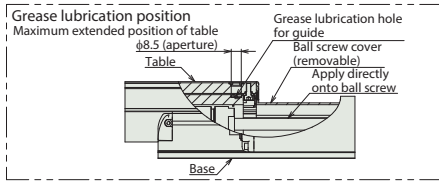

Cross section of Z-Z  
Details of T-slot and base mounting counterbored holes

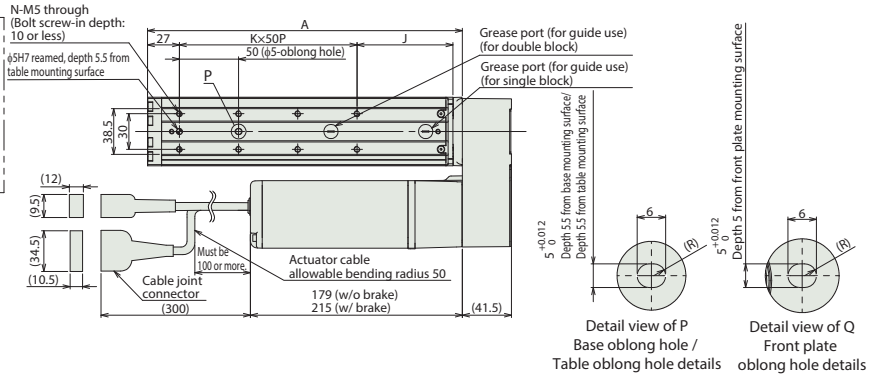

Detail view of P  
Base oblong hole / Table oblong hole details

Detail view of Q  
Front plate oblong hole details

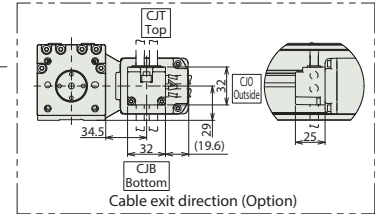
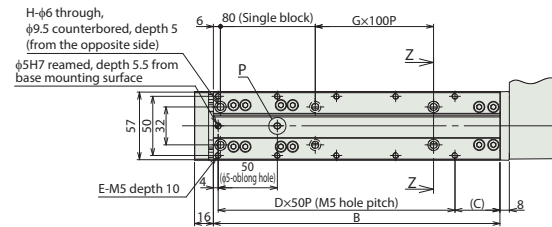
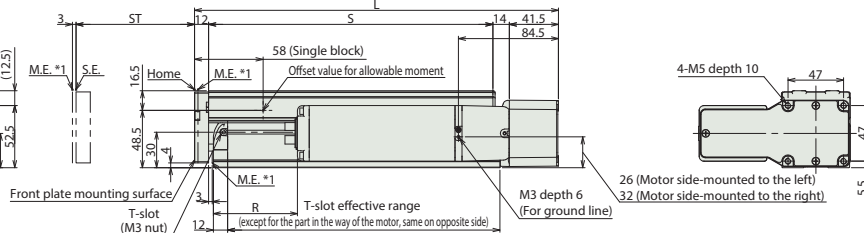
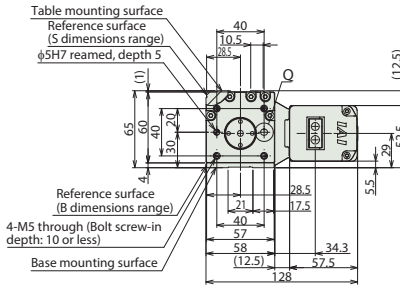

■ Dimensions and Mass by Stroke

ST	25	50	75	100	125	150	175	200	
L	182.5	207.5	232.5	257.5	282.5	307.5	332.5	357.5	
A	141	166	191	216	241	266	291	316	
B	117	142	167	192	217	242	267	292	
C	13	38	13	38	13	38	13	38	
D	2	2	3	3	4	4	5	5	
E	6	6	8	8	10	10	12	12	
G	0	0	0	0	1	1	1	1	
H	4	4	4	4	4	6	6	6	
J	56	81	56	81	56	81	56	81	
K	1	1	2	2	3	3	4	4	
N	4	4	6	6	8	8	10	10	
R (Note)	W/o brake	-54	-29	-4	21	46	71	96	121
	W/ brake	-90	-65	-40	-15	10	35	60	85
	S	115	140	165	190	215	240	265	290
Mass (kg)	W/o brake	2.4	2.6	2.8	2.9	3.1	3.3	3.4	3.6
	W/ brake	2.7	2.9	3.1	3.2	3.4	3.6	3.7	3.9

(Note) If the length for R is negative, the length of the actuator body is shorter than the motor unit.

Applicable Controllers

The RCS4 series actuators can be operated by the controllers indicated below. Please select the type depending on your intended use.

Name	External view	Max. number of connectable axes	Input power	Control method				Maximum number of positioning points	Reference page	
				Positioner	Pulse train	Program	Network * Option			
SCON-CB/CGB		1	Single phase 100V/200VAC	●	●	-	DeviceNet CC-Link CC-Link IE CompoNet MECHATROLINK EtherCAT EtherNet/IP EtherCAT	512 (768 for network spec.)	Please contact IAI for more information.	
SCON-LC/LCG		1		-	-	●		512 (768 for network spec.)		
SCON-CAL/CGAL		1		●	-	-		512 (768 for network spec.)		
MSCON-C		6		This model is network-compatible only.				256		
SSEL-CS		2		●	-	●		20000		
XSEL-P/Q/RA/SA		8	Single phase 200VAC Three-phase 200VAC	-	-	●	55000 (Depending on the type)			

Note:  
The type of compatible networks will vary depending on the controller. Please refer to the reference page for more information.

# RCS4-TA6R <Double Block Specification>

Battery-less Absolute

Motor Unit Type

Side-mounted Motor

Body Width 60\* mm

200v AC Servo Motor

Model Specification Items	<b>RCS4</b> — <b>TA6R</b> — <b>WA</b> — <b>100</b> — <input type="checkbox"/> — <input type="checkbox"/> — <b>T2</b> — <input type="checkbox"/> — <b>DB</b> — <input type="checkbox"/>	* Body width does not include the width of the side-mounted motor.						
Series	Type	Encoder Type	Motor Type	Lead	Stroke	Applicable Controllers	Cable Length	Options
WA: Battery-less Absolute	100: Servo motor 100W	12:12mm 6: 6mm 3: 3mm	45:45mm 320:320mm	T2:SCON MSCON SSEL XSEL-P/Q XSEL-RA/SA	N : None P : 1m S : 3m M : 5m X□□ : Specified Length R□□ : Robot Cable	Refer to Options table below.		

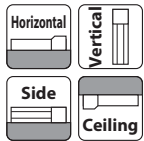

\* Depending on the model, there may be some limitations to using the vertical, side, and ceiling mount positions. Please refer to the Selection Notes on P.138 for more information.



- POINT Selection Notes**
- (1) Longer strokes may cause the maximum speed to decrease due to resonance of the ball screw. Be sure to check the maximum speed of the desired stroke in the Actuator Specifications table, which can be found below.
  - (2) Both the horizontal and vertical payloads assume operation at an acceleration of 0.3G.
  - (3) When the acceleration is increased, the payload will be reduced. Please refer to "Table of Payload by Acceleration" on P.139 for more details.
  - (4) Estimated allowable duty varies depending on operating conditions (payload, acceleration/deceleration, etc.). Please refer to P. 149 for more information.
  - (5) Please refer to the graphs shown on P.148 for the allowable load mass.

## Actuator Specifications

### Lead and Payload

Model Number	Motor wattage (W)	Lead (mm)	Max. payload		Rated thrust (N)	Stroke (mm)
			Horizontal (kg)	Vertical (kg)		
RCS4-TA6R-WA-100-12-①-T2-②-DB-③	100	12	14	6	142	45~120 (25mm increments) 170~320 (50mm increments)
RCS4-TA6R-WA-100-6-①-T2-②-DB-③		6	20	10	283	
RCS4-TA6R-WA-100-3-①-T2-②-DB-③		3	20	12	566	

Legend: ① Stroke ② Cable Length ③ Option

### Stroke and Max Speed (Unit: mm/s)

Lead	Stroke	45~270 (mm)	320 (mm)
		12	720
6	360	285	
3	180	140	

### ① Stroke

① Stroke (mm)	RCS4-TA6R	① Stroke (mm)	RCS4-TA6R
45	○	170	○
70	○	220	○
95	○	270	○
120	○	320	○

### ② Cable Length

Type	Cable Code
Standard	P(1m)
	S(3m)
	M(5m)
Specified length (Standard cable)	X06(6m) ~ X10(10m)
	X11(11m) ~ X15(15m)
	X16(16m) ~ X20(20m)
Robot cable	R01(1m) ~ R03(3m)
	R04(4m) ~ R05(5m)
	R06(6m) ~ R10(10m)
	R11(11m) ~ R15(15m)
	R16(16m) ~ R20(20m)

### ③ Options

Name	Option Code	Reference Page
Brake	<b>B</b>	See P.131
Cable exit direction (Top)	<b>CJT</b>	See P.131
Cable exit direction (Bottom)	<b>CJB</b>	See P.131
Cable exit direction (Outside)	<b>CJO</b>	See P.131
Motor side-mounted to left (standard)	<b>ML</b>	See P.135
Motor side-mounted to right	<b>MR</b>	See P.135
Non-motor end specification	<b>NM</b>	See P.136

### Actuator Specifications

Item	Description
Drive system	Ball screw φ10mm, rolled C10
Positioning repeatability	±0.01mm
Lost motion	0.1 mm or less
Base	Material: Aluminum with white alumite treatment
Allowable static moment	Ma direction 169N-m, Mb direction 242N-m, Mc direction 137N-m
Allowable dynamic moment (*1)	Ma direction 49.5N-m, Mb direction 70.7N-m, Mc direction 40N-m
Ambient operating temp. & humidity	0~40°C, 85% RH or less (Non-condensing)

(\*1) Assumes a standard rated life of 5,000km. The running life will vary depending on operation and installation conditions. Please contact IAI America for details of the running life. See page 146 for moment load directions. If the moment loads in Ma/Mb/Mc are within the allowable ranges, there is no overhang length limit. Please refer to the instruction manual for the amount of displacement of the table.

CAD drawings can be downloaded from our website.  
www.intelligentactuator.com



\*1 When the table is returning to its home position, please be mindful of possible interference from surrounding objects, as it will travel until it reaches the M.E.  
M.E: Mechanical end S.E: Stroke end

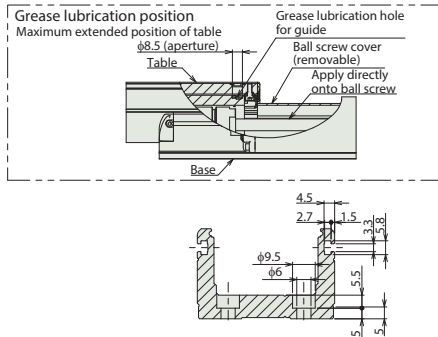

Cross section of Z-Z  
Details of T-slot and base mounting counterbored holes

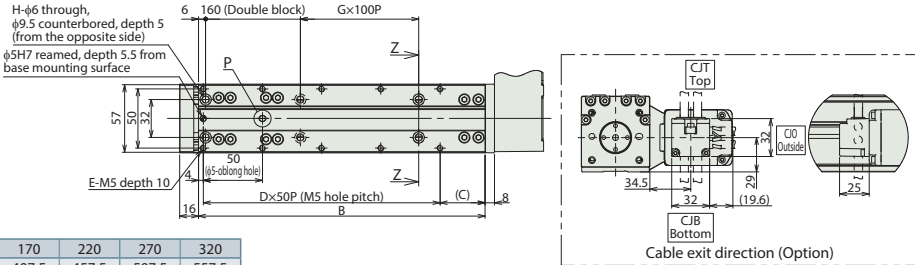
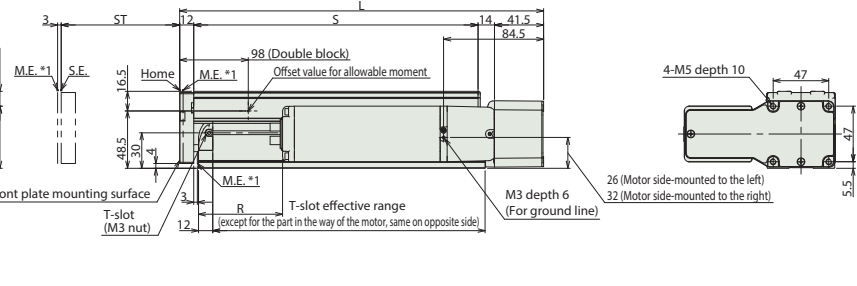
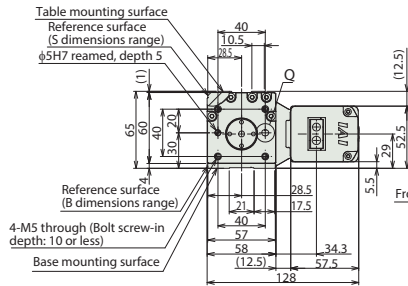
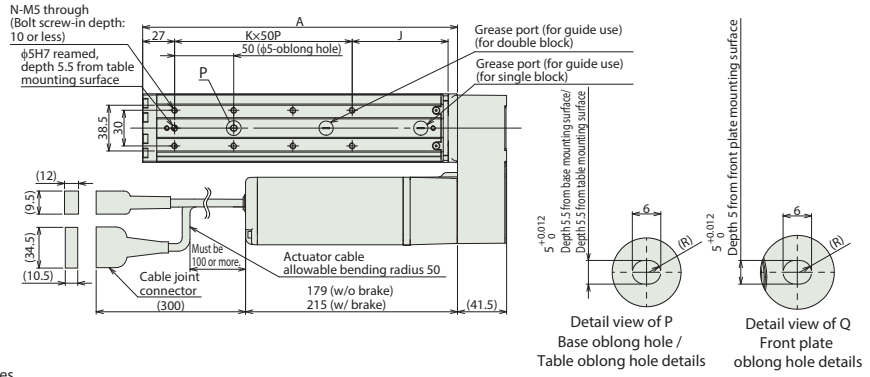

■ Dimensions and Mass by Stroke

ST	45	70	95	120	170	220	270	320	
L	282.5	307.5	332.5	357.5	407.5	457.5	507.5	557.5	
A	241	266	291	316	366	416	466	516	
B	217	242	267	292	342	392	442	492	
C	13	38	13	38	38	38	38	38	
D	4	4	5	5	6	7	8	9	
E	10	10	12	12	14	16	18	20	
G	0	0	0	0	1	1	2	2	
H	4	4	4	4	6	6	8	8	
J	56	81	56	81	81	81	81	81	
K	3	3	4	4	5	6	7	8	
N	8	8	10	10	12	14	16	18	
R (Motor)	W/o brake	46	71	96	121	171	221	271	321
	W/ brake	10	35	60	85	135	185	235	285
	S	215	240	265	290	340	390	440	490
Mass (kg)	W/o brake	3.3	3.4	3.6	3.8	4.1	4.4	4.8	5.1
	W/ brake	3.6	3.7	3.9	4.1	4.4	4.7	5.1	5.4

(Note) If the length for R is negative, the length of the actuator body is shorter than the motor unit.

Applicable Controllers

The RCS4 series actuators can be operated by the controllers indicated below. Please select the type depending on your intended use.

Name	External view	Max. number of connectable axes	Input power	Control method				Maximum number of positioning points	Reference page	
				Positioner	Pulse train	Program	Network * Option			
SCON-CB/CGB		1	Single phase 100V/200VAC	●	●	-	DeviceNet CC-Link CC-Link IE CompoNet MECHATROLINK EtherCAT EtherNet/IP PROFINET	512 (768 for network spec.)	Please contact IAI for more information.	
SCON-LC/LCG		1		-	-	●		512 (768 for network spec.)		
SCON-CAL/CGAL		1		●	-	-		512 (768 for network spec.)		
MSCON-C		6		This model is network-compatible only.				256		
SSEL-CS		2		●	-	●		20000		
XSEL-P/Q/R/SA		8	Single phase 200VAC Three-phase 200VAC	-	-	●	55000 (Depending on the type)			

Note:  
The type of compatible networks will vary depending on the controller. Please refer to the reference page for more information.

Foreword  
Slider Type  
Wide Slider Type  
Rod Type  
Radial Cylinder  
Wide Radial Cylinder  
Table Type  
Cleanroom Slider  
Cleanroom Wide Slider  
Options  
Reference Data  
Controller

# RCS4-TA7R <Single Block Specification>

Battery-less Absolute
Motor Unit Type
Side-mounted Motor
Body Width 70\* mm
200v AC Servo Motor

Model Specification Items	<b>RCS4</b> — <b>TA7R</b> — <b>WA</b> — <b>200</b> — <input type="checkbox"/> — <input type="checkbox"/> — <b>T2</b> — <input type="checkbox"/> — <input type="checkbox"/>	* Body width does not include the width of the side-mounted motor.						
Series	Type	Encoder Type	Motor Type	Lead	Stroke	Applicable Controllers	Cable Length	Options
WA: Battery-less Absolute	200: Servo motor 200W	24:24mm 16:16mm 8: 8mm 4: 4mm	25:25mm 300:300mm	T2:SCON MSCON SSEL XSEL-P/Q XSEL-RA/SA	N : None P : 1m S : 3m M : 5m X <input type="checkbox"/> : Specified Length R <input type="checkbox"/> : Robot Cable	Refer to Options table below.		

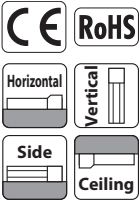

\* Depending on the model, there may be some limitations to using the vertical, side, and ceiling mount positions. Please refer to the Selection Notes on P.138 for more information.



**POINT Selection Notes**

- Both the horizontal and vertical payloads assume operation at an acceleration of 0.3G.
- When the acceleration is increased, the payload will be reduced. Please refer to "Table of Payload by Acceleration" on P.139 for more details.
- Estimated allowable duty varies depending on operating conditions (payload, acceleration/deceleration, etc.). Please refer to P.149 for more information.
- Please refer to the graphs shown on P.148 for the allowable load mass.

## Actuator Specifications

### Lead and Payload

Model Number	Motor wattage (W)	Lead (mm)	Max. payload		Rated thrust (N)	Stroke (mm)
			Horizontal (kg)	Vertical (kg)		
RCS4-TA7R-WA-200-24-①-T2-②-③	200	24	12	5	142	25~200 (25mm increments) 250~300 (50mm increments)
RCS4-TA7R-WA-200-16-①-T2-②-③		16	15	10	214	
RCS4-TA7R-WA-200-8-①-T2-②-③		8	15	18	427	
RCS4-TA7R-WA-200-4-①-T2-②-③		4	15	20	855	

Legend: ① Stroke ② Cable Length ③ Option

### Stroke and Max Speed (Unit: mm/s)

Lead	Stroke	25~300 (mm)
24		1200
16		960
8		480
4		240

### ① Stroke

① Stroke (mm)	RCS4-TA7R	① Stroke (mm)	RCS4-TA7R
25	○	150	○
50	○	175	○
75	○	200	○
100	○	250	○
125	○	300	○

### ② Cable Length

Type	Cable Code
Standard	P(1m)
	S(3m)
	M(5m)
Specified length (Standard cable)	X06(6m) ~ X10(10m)
	X11(11m) ~ X15(15m)
	X16(16m) ~ X20(20m)
Robot cable	R01(1m) ~ R03(3m)
	R04(4m) ~ R05(5m)
	R06(6m) ~ R10(10m)
	R11(11m) ~ R15(15m)
	R16(16m) ~ R20(20m)
	R16(16m) ~ R20(20m)

### ③ Options

Name	Option Code	Reference Page
Brake	<b>B</b>	See P.131
Cable exit direction (Top)	<b>CJT</b>	See P.131
Cable exit direction (Bottom)	<b>CJB</b>	See P.131
Cable exit direction (Outside)	<b>CJO</b>	See P.131
Motor side-mounted to left (standard)	<b>ML</b>	See P.135
Motor side-mounted to right	<b>MR</b>	See P.135
Non-motor end specification	<b>NM</b>	See P.136

### Actuator Specifications

Item	Description
Drive system	Ball screw φ12mm, rolled C10
Positioning repeatability	±0.01mm
Lost motion	0.1 mm or less
Base	Material: Aluminum with white alumite treatment
Allowable static moment	Ma direction 115N·m, Mb direction 115N·m, Mc direction 229N·m
Allowable dynamic moment (*1)	Ma direction 44.7N·m, Mb direction 44.7N·m, Mc direction 89.1N·m
Ambient operating temp. & humidity	0~40°C, 85% RH or less (Non-condensing)

(\*1) Assumes a standard rated life of 5,000km. The running life will vary depending on operation and installation conditions. Please contact IAI America for details of the running life. See page 146 for moment load directions. If the moment loads in Ma/Mb/Mc are within the allowable ranges, there is no overhang length limit. Please refer to the instruction manual for the amount of displacement of the table.





# RCS4-TA7R <Double Block Specification>

Battery-less Absolute

Motor Unit Type

Side-mounted Motor

Body Width 70\* mm

200v AC Servo Motor

Model Specification Items	<b>RCS4</b> — <b>TA7R</b> — <b>WA</b> — <b>200</b> — [ ] — [ ] — <b>T2</b> — [ ] — <b>DB</b> — [ ]	* Body width does not include the width of the side-mounted motor.						
Series	Type	Encoder Type	Motor Type	Lead	Stroke	Applicable Controllers	Cable Length	Options
WA: Battery-less Absolute	200: Servo motor 200W	16:16mm 8: 8mm 4: 4mm	40:40mm 390:390mm	T2:SCON MSCON SSEL XSEL-P/Q XSEL-RA/SA	N : None P : 1m S : 3m M : 5m X□ : Specified Length R□ : Robot Cable	Refer to Options table below.		



\* Depending on the model, there may be some limitations to using the vertical, side, and ceiling mount positions. Please refer to the Selection Notes on P.138 for more information.



- POINT Selection Notes**
- (1) Longer strokes may cause the maximum speed to decrease due to resonance of the ball screw. Be sure to check the maximum speed of the desired stroke in the Actuator Specifications table, which can be found below.
  - (2) Both the horizontal and vertical payloads assume operation at an acceleration of 0.3G.
  - (3) When the acceleration is increased, the payload will be reduced. Please refer to "Table of Payload by Acceleration" on P.139 for more details.
  - (4) Estimated allowable duty varies depending on operating conditions (payload, acceleration/deceleration, etc.). Please refer to P. 149 for more information.
  - (5) Please refer to the graphs shown on P.148 for the allowable load mass.

## Actuator Specifications

### Lead and Payload

Model Number	Motor wattage (W)	Lead (mm)	Max. payload		Rated thrust (N)	Stroke (mm)
			Horizontal (kg)	Vertical (kg)		
RCS4-TA7R-WA-200-16-①-T2-②-DB-③	200	16	25	8	214	40~90 (25mm increments)
RCS4-TA7R-WA-200-8-①-T2-②-DB-③		8	30	18	427	140~390 (50mm increments)
RCS4-TA7R-WA-200-4-①-T2-②-DB-③		4	30	24	855	

Legend: ① Stroke ② Cable Length ③ Option

### Stroke and Max Speed

(Unit: mm/s)

Lead	Stroke	40~290 (mm)		
		340 (mm)	390 (mm)	
16	960	730	600	
8	480	365	300	
4	240	180	150	

### ① Stroke

① Stroke (mm)	RCS4-TA7R	① Stroke (mm)	RCS4-TA7R
40	○	240	○
65	○	290	○
90	○	340	○
140	○	390	○
190	○		

### ② Cable Length

Type	Cable Code
Standard	P(1m)
	S(3m)
	M(5m)
Specified length (Standard cable)	X06(6m) ~ X10(10m)
	X11(11m) ~ X15(15m)
	X16(16m) ~ X20(20m)
Robot cable	R01(1m) ~ R03(3m)
	R04(4m) ~ R05(5m)
	R06(6m) ~ R10(10m)
	R11(11m) ~ R15(15m)
	R16(16m) ~ R20(20m)

### ③ Options

Name	Option Code	Reference Page
Brake	<b>B</b>	See P.131
Cable exit direction (Top)	<b>CJT</b>	See P.131
Cable exit direction (Bottom)	<b>CJB</b>	See P.131
Cable exit direction (Outside)	<b>CJO</b>	See P.131
Motor side-mounted to left (standard)	<b>ML</b>	See P.135
Motor side-mounted to right	<b>MR</b>	See P.135
Non-motor end specification	<b>NM</b>	See P.136

### Actuator Specifications

Item	Description
Drive system	Ball screw φ12mm, rolled C10
Positioning repeatability	±0.01mm
Lost motion	0.1 mm or less
Base	Material: Aluminum with white alumite treatment
Allowable static moment	Ma direction 620N-m, Mb direction 620N-m, Mc direction 458N-m
Allowable dynamic moment (*1)	Ma direction 196N-m, Mb direction 196N-m, Mc direction 145N-m
Ambient operating temp. & humidity	0~40°C, 85% RH or less (Non-condensing)

(\*1) Assumes a standard rated life of 5,000km. The running life will vary depending on operation and installation conditions. Please contact IAI America for details of the running life.

See page 146 for moment load directions.

If the moment loads in Ma/Mb/Mc are within the allowable ranges, there is no overhang length limit. Please refer to the instruction manual for the amount of displacement of the table.



# RCS4CR-SA4C



## Model Specification Items

<b>RCS4CR</b>	<b>SA4C</b>	<b>WA</b>	<b>60</b>			<b>T2</b>		
Series	Type	Encoder Type	Motor Type	Lead	Stroke	Applicable Controllers	Cable Length	Options
		WA: Battery-less Absolute	60: Servo motor 60W	16: 16mm 10: 10mm 5: 5mm 2.5: 2.5mm	50: 50mm 500: 500mm (50mm increments)	T2: SCON MSCON SSEL XSEL-P/Q XSEL-RA/SA	N: None P: 1m S: 3m M: 5m X□□: Specified Length R□□: Robot Cable	Refer to Options table below.

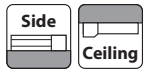

\* Depending on the model, there may be some limitations to using the vertical, side, and ceiling mount positions. Please refer to the Selection Notes on P.138 for more information.



- (1) Longer strokes may cause the maximum speed to decrease due to resonance of the ball screw. Be sure to check the maximum speed of the desired stroke in the Actuator Specifications table, which can be found below.
- (2) Both the horizontal and vertical payloads assume operation at an acceleration of 0.3G.
- (3) When the acceleration is increased, the payload will be reduced. Please refer to "Table of Payload by Acceleration" on P.139 for more details.
- (4) Estimated allowable duty varies depending on operating conditions (payload, acceleration/deceleration, etc.). Please refer to P. 149 for more information.

## Actuator Specifications

### Lead and Payload

Model Number	Motor wattage (W)	Lead (mm)	Max. payload		Rated thrust (N)	Stroke (mm)
			Horizontal (kg)	Vertical (kg)		
RCS4CR-SA4C-WA-60-16-①-T2-②-③	60	16	10	3	53	50~500 (50mm increments)
RCS4CR-SA4C-WA-60-10-①-T2-②-③		10	14	5	85	
RCS4CR-SA4C-WA-60-5-①-T2-②-③		5	17	8	170	
RCS4CR-SA4C-WA-60-2.5-①-T2-②-③		2.5	20	12	340	

Legend: ① Stroke ② Cable Length ③ Option

### Stroke and Max Speed/Suction Amount (Unit: mm/s)

Lead	Stroke	50~450 (50mm increments)		Suction amount (Nℓ/min)
		500 (mm)		
16		960	875	60
10		600	555	40
5		300	275	20
2.5		150	135	10

### ① Stroke

① Stroke (mm)	RCS4CR-SA4C	① Stroke (mm)	RCS4CR-SA4C
50	○	300	○
100	○	350	○
150	○	400	○
200	○	450	○
250	○	500	○

### ② Cable Length

Type	Cable Code
Standard	P(1m)
	S(3m)
	M(5m)
Specified length (Standard cable)	X06(6m) ~ X10(10m)
	X11(11m) ~ X15(15m)
	X16(16m) ~ X20(20m)
Robot cable	R01(1m) ~ R03(3m)
	R04(4m) ~ R05(5m)
	R06(6m) ~ R10(10m)
	R11(11m) ~ R15(15m)
	R16(16m) ~ R20(20m)

### ③ Options

Name	Option Code	Reference Page
Brake	B	See P.131
Cable exit direction (Top)	CJT	See P.131
Cable exit direction (Right)	CJR	See P.131
Cable exit direction (Left)	CJL	See P.131
Cable exit direction (Bottom)	CJB	See P.131
High-Precision specification (*1)	HPR	See P.134
Non-motor end specification	NM	See P.136
Air suction joint in opposite position	VR	See P.137
Double slide specification (*2)	W	See P.137

(\*1) Double slider specification cannot be selected.

(\*2) Some leads cannot be selected. (Please see P. 150)

### Actuator Specifications

Item	Description
Drive system	Ball screw φ8mm, rolled C10
Positioning repeatability (*1)	±0.01mm [±0.005mm]
Lost motion	0.1mm or less
Base	Material: Aluminum with white alumite treatment
Allowable static moment	Ma direction 13.0N·m, Mb direction 18.6N·m, Mc direction 25.3N·m
Allowable dynamic moment (*2)	Ma direction 5.0N·m, Mb direction 7.1N·m, Mc direction 9.7N·m
Cleanliness	Class 10 (Fed.Std.209D), class 2.5 or equivalent (ISO 14644-1 Standard)
Ambient operating temp. & humidity	0~40°C, 85% RH or less (Non-condensing)

\* Reference for overhang load length: Ma direction: 150mm or less, Mb, Mc direction: 150mm or less

(\*1) Values in [ ] are for high precision specification.

(\*2) Assumes a standard rated life of 5,000km. The running life will vary depending on operation and installation conditions. Please contact IAI America for details of the running life. See page 146 for moment load directions.

If the moment loads in Ma/Mb/Mc are within the allowable ranges, there is no overhang length limit.



\*1 When the slider is returning to its home position, please be careful of interference from surrounding objects, as it will travel until it reaches the M.E.  
M.E: Mechanical end S.E: Stroke end

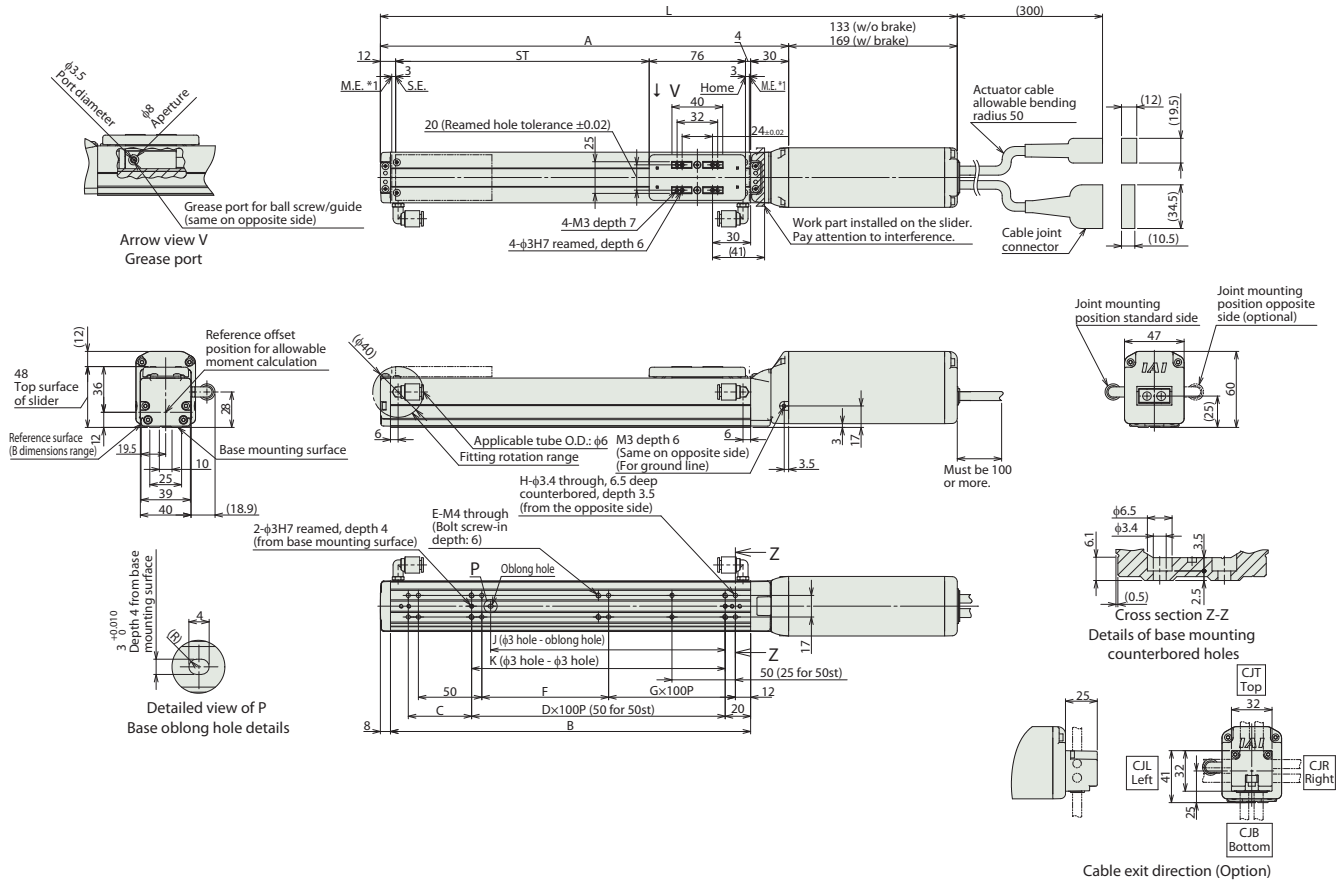

**Dimensions and Mass by Stroke**

L	Stroke	50	100	150	200	250	300	350	400	450	500
	W/o brake	305	355	405	455	505	555	605	655	705	755
	W/ brake	341	391	441	491	541	591	641	691	741	791
	A	172	222	272	322	372	422	472	522	572	622
	B	134	184	234	284	334	384	434	484	534	584
	C	50	50	100	50	100	50	100	50	100	50
	D	-	1	1	2	2	3	3	4	4	5
	E	6	6	6	8	8	10	10	12	12	14
	F	50	100	50	100	50	100	50	100	50	100
	G	0	0	1	1	2	2	3	3	4	4
	H	8	8	10	10	12	12	14	14	16	16
	J	35	85	85	185	185	285	285	385	385	485
	K	50	100	100	200	200	300	300	400	400	500
Mass (kg)	W/o brake	1.2	1.3	1.4	1.5	1.5	1.6	1.7	1.8	1.9	2.0
	W/ brake	1.4	4.5	4.6	1.7	1.7	1.8	1.9	2	2.1	2.2

**Applicable Controllers**

The RCS4 series actuators can be operated by the controllers indicated below. Please select the type depending on your intended use.

Name	External view	Max. number of connectable axes	Input power	Control method				Maximum number of positioning points	Reference page	
				Positioner	Pulse train	Program	Network * Option			
SCON-CB/CGB		1	Single phase 100V/200VAC	●	●	-	DeviceNet CC-Link CC-Link IE CompoNet MECHATROLINK EtherCAT EtherNet/IP	512 (768 for network spec.)	Please contact IAI for more information.	
SCON-LC/LCG		1		-	-	●		512 (768 for network spec.)		
SCON-CAL/CGAL		1		●	-	-		512 (768 for network spec.)		
MSCON-C		6		This model is network-compatible only.				256		
SSEL-CS		2		●	-	●		20000		
XSEL-P/Q/RA/SA		8	Single phase 200VAC Three-phase 200VAC	-	-	●	55000 (Depending on the type)			

Note: The type of compatible networks will vary depending on the controller. Please refer to the reference page for more information.

Foreword  
Slider Type  
Wide Slider Type  
Rod Type  
Radial Cylinder  
Wide Radial Cylinder  
Table Type  
Cleanroom Slider  
Cleanroom Wide Slider  
Options  
Reference Data  
Controller

# RCS4CR-SA6C



## Model Specification Items

<b>RCS4CR</b>	<b>SA6C</b>	<b>WA</b>	<b>100</b>			<b>T2</b>		
Series	Type	Encoder Type	Motor Type	Lead	Stroke	Applicable Controllers	Cable Length	Options
		WA: Battery-less Absolute	100: Servo motor 100W	20:20mm 12:12mm 6: 6mm 3: 3mm	50:50mm 800:800mm (50mm increments)	T2:SCON MSCON SSEL XSEL-P/Q XSEL-RA/SA	N : None P : 1m S : 3m M : 5m X□ : Specified Length R□ : Robot Cable	Refer to Options table below.

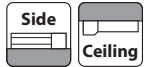

\* Depending on the model, there may be some limitations to using the vertical, side, and ceiling mount positions. Please refer to the Selection Notes on P.138 for more information.



- (1) Longer strokes may cause the maximum speed to decrease due to resonance of the ball screw. Be sure to check the maximum speed of the desired stroke in the Actuator Specifications table, which can be found below.
- (2) Both the horizontal and vertical payloads assume operation at an acceleration of 0.3G.
- (3) When the acceleration is increased, the payload will be reduced. Please refer to "Table of Payload by Acceleration" on P.139 for more details.
- (4) Estimated allowable duty varies depending on operating conditions (payload, acceleration/deceleration, etc.). Please refer to P. 149 for more information.

## Actuator Specifications

### Lead and Payload

Model Number	Motor wattage (W)	Lead (mm)		Max. payload (kg)		Rated thrust (N)	Stroke (mm)
		Horizontal (kg)	Vertical (kg)	Horizontal (kg)	Vertical (kg)		
RCS4CR-SA6C-WA-100-20-①-T2-②-③	100	20	18	6	85	50~800 (50mm increments)	
RCS4CR-SA6C-WA-100-12-①-T2-②-③		12	30	11	142		
RCS4CR-SA6C-WA-100-6-①-T2-②-③		6	45	15	283		
RCS4CR-SA6C-WA-100-3-①-T2-②-③		3	45	15	566		

Legend: ① Stroke ② Cable Length ③ Option

### Stroke and Max Speed/Suction Amount

(Unit: mm/s)

Stroke	Suction amount (Nz/min)							
	50~500 (50mm increments)	550 (mm)	600 (mm)	650 (mm)	700 (mm)	750 (mm)	800 (mm)	
20	1200	1130	970	840	735	650	575	100
12	720	620	535	460	405	355	315	70
6	360	305	265	230	200	175	155	30
3	180	150	130	115	100	85	75	15

### ① Stroke

① Stroke (mm)	RCS4CR-SA6C	① Stroke (mm)	RCS4CR-SA6C
50	○	450	○
100	○	500	○
150	○	550	○
200	○	600	○
250	○	650	○
300	○	700	○
350	○	750	○
400	○	800	○

### ② Cable Length

Type	Cable Code
Standard	P(1m)
	S(3m)
	M(5m)
Specified length (Standard cable)	X06(6m) ~X10(10m)
	X11(11m)~X15(15m)
	X16(16m)~X20(20m)
Robot cable	R01(1m) ~R03(3m)
	R04(4m) ~R05(5m)
	R06(6m) ~R10(10m)
	R11(11m)~R15(15m)
	R16(16m)~R20(20m)

### ③ Options

Name	Option Code	Reference Page
Brake	<b>B</b>	See P.131
Cable exit direction (Top)	<b>CJT</b>	See P.131
Cable exit direction (Right)	<b>CJR</b>	See P.131
Cable exit direction (Left)	<b>CJL</b>	See P.131
Cable exit direction (Bottom)	<b>CJB</b>	See P.131
High-Precision specification (*1)	<b>HPR</b>	See P.134
Non-motor end specification	<b>NM</b>	See P.136
Air suction joint in opposite position	<b>VR</b>	See P.137
Double slide specification (*2)	<b>W</b>	See P.137

(\*1) Double slider specification cannot be selected.

(\*2) Some leads cannot be selected. (Please see P. 150)

### Actuator Specifications

Item	Description
Drive system	Ball screw φ10mm, rolled C10
Positioning repeatability (*1)	±0.01mm [±0.005mm]
Lost motion	0.1 mm or less
Base	Material: Aluminum with white alumite treatment
Allowable static moment	Ma direction: 48.5N·m, Mb direction: 69.3N·m, Mc direction: 103N·m
Allowable dynamic moment (*2)	Ma direction: 11.6N·m, Mb direction: 16.6N·m, Mc direction: 24.6N·m
Cleanliness	Class 10 (Fed.Std.209D), class 2.5 or equivalent (ISO 14644-1 Standard)
Ambient operating temp. & humidity	0~40°C, 85% RH or less (Non-condensing)

\* Reference for overhang load length: Ma direction: 220mm or less, Mb, Mc direction: 220mm or less

(\*1) Values in [ ] are for high precision specification.

(\*2) Assumes a standard rated life of 5,000km. The running life will vary depending on operation and installation conditions. Please contact IAI America for details of the running life.

See page 146 for moment load directions.

If the moment loads in Ma/Mb/Mc are within the allowable ranges, there is no overhang length limit.



\*1 When the slider is returning to its home position, please be careful of interference from surrounding objects, as it will travel until it reaches the M.E.  
M.E: Mechanical end S.E: Stroke end

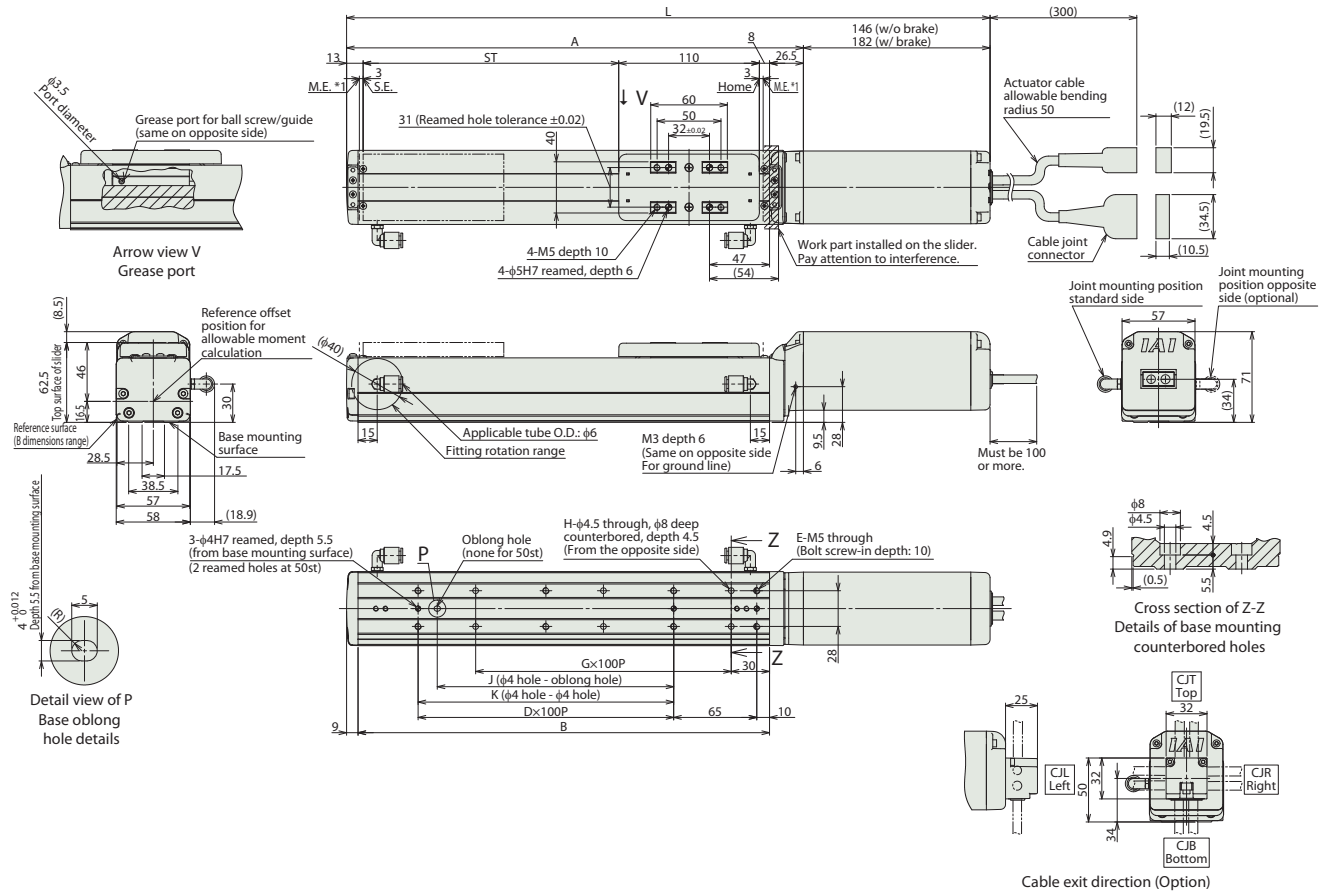

■ Dimensions and Mass by Stroke

L	Stroke	50	100	150	200	250	300	350	400	450	500	550	600	650	700	750	800
	W/o brake	353.5	403.5	453.5	503.5	553.5	603.5	653.5	703.5	753.5	803.5	853.5	903.5	953.5	1003.5	1053.5	1103.5
W/ brake	389.5	439.5	489.5	539.5	589.5	639.5	689.5	739.5	789.5	839.5	889.5	939.5	989.5	1039.5	1089.5	1139.5	1139.5
A	207.5	257.5	307.5	357.5	407.5	457.5	507.5	557.5	607.5	657.5	707.5	757.5	807.5	857.5	907.5	957.5	957.5
B	172	222	272	322	372	422	472	522	572	622	672	722	772	822	872	922	922
D	0	1	1	2	2	3	3	4	4	5	5	6	6	7	7	8	8
E	4	6	6	8	8	10	10	12	12	14	14	16	16	18	18	20	20
G	1	1	2	2	3	3	4	4	5	5	6	6	7	7	8	8	8
H	4	4	6	6	8	8	10	10	12	12	14	14	16	16	18	18	18
J	0	85	85	185	185	285	285	385	385	485	485	585	585	685	685	785	785
K	0	100	100	200	200	300	300	400	400	500	500	600	600	700	700	800	800
Mass (kg)	W/o brake	2.0	2.2	2.4	2.6	2.7	2.9	3.1	3.3	3.4	3.6	3.8	4.0	4.2	4.3	4.5	4.7
	W/ brake	2.3	2.5	2.7	2.9	3	3.2	3.4	3.6	3.7	3.9	4.1	4.3	4.5	4.6	4.8	5

Applicable Controllers

The RCS4 series actuators can be operated by the controllers indicated below. Please select the type depending on your intended use.

Name	External view	Max. number of connectable axes	Input power	Control method				Maximum number of positioning points	Reference page	
				Positioner	Pulse train	Program	Network * Option			
SCON-CB/CGB		1	Single phase 100V/200VAC	●	●	-	DeviceNet CC-Link CC-Link IE CompoNet MECHATROLINK EtherCAT EtherNet/IP	512 (768 for network spec.)	Please contact IAI for more information.	
SCON-LC/LCG		1		-	-	●		512 (768 for network spec.)		
SCON-CAL/CGAL		1		●	-	-		512 (768 for network spec.)		
MSCON-C		6		This model is network-compatible only.				256		
SSEL-CS		2		●	-	●		20000		
XSEL-P/Q/RA/SA		8	Single phase 200VAC Three-phase 200VAC	-	-	●	55000 (Depending on the type)			

Note:  
The type of compatible networks will vary depending on the controller. Please refer to the reference page for more information.

# RCS4CR-SA7C

±10μm Standard
±5μm High Precision Optional
Simple Dust-proof
Battery-less Absolute
Motor Unit Type
Coupled Motor
Body Width 70 mm
200v AC Servo Motor

Model Specification Items	<b>RCS4CR</b> — <b>SA7C</b> — <b>WA</b> — <b>200</b> — [ ] — [ ] — [ ]	<b>T2</b> — [ ] — [ ]						
Series	Type	Encoder Type	Motor Type	Lead	Stroke	Applicable Controllers	Cable Length	Options
		WA: Battery-less Absolute	200: Servo motor 200W	24:24mm 16:16mm 8: 8mm 4: 4mm	50:50mm 800:800mm (50mm increments)	T2:SCON MSCON SSEL XSEL-P/Q XSEL-RA/SA	N : None P : 1m S : 3m M : 5m X□□ : Specified Length R□□ : Robot Cable	Refer to Options table below.

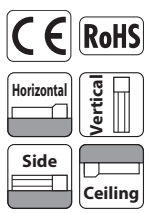

\* Depending on the model, there may be some limitations to using the vertical, side, and ceiling mount positions. Please refer to the Selection Notes on P.138 for more information.



**POINT Selection Notes**

- (1) Longer strokes may cause the maximum speed to decrease due to resonance of the ball screw. Be sure to check the maximum speed of the desired stroke in the Actuator Specifications table, which can be found below.
- (2) Both the horizontal and vertical payloads assume operation at an acceleration of 0.3G.
- (3) When the acceleration is increased, the payload will be reduced. Please refer to "Table of Payload by Acceleration" on P.139 for more details.
- (4) Estimated allowable duty varies depending on operating conditions (payload, acceleration/deceleration, etc.). Please refer to P. 149 for more information.

## Actuator Specifications

### Lead and Payload

Model Number	Motor wattage (W)	Lead (mm)		Max. payload (kg)		Rated thrust (N)	Stroke (mm)
		Horizontal (kg)	Vertical (kg)	Horizontal (kg)	Vertical (kg)		
RCS4CR-SA7C-WA-200-24-①-T2-②-③	200	24	30	7	142	50~800 (50mm increments)	
RCS4CR-SA7C-WA-200-16-①-T2-②-③		16	40	12	214		
RCS4CR-SA7C-WA-200-8-①-T2-②-③		8	45	20	427		
RCS4CR-SA7C-WA-200-4-①-T2-②-③		4	50	25	855		

Legend: ① Stroke ② Cable Length ③ Option

### Stroke and Max Speed/Suction Amount

(Unit: mm/s)

Stroke	Suction amount (N <sub>E</sub> /min)							
	50~500 (50mm increments)	550 (mm)	600 (mm)	650 (mm)	700 (mm)	750 (mm)	800 (mm)	850 (mm)
24	1500	1440	1240	1095	965	850	760	90
16	1000	965	830	720	635	560	500	70
8	500	475	410	355	315	275	245	40
4	240	235	205	175	155	135	120	30

### ① Stroke

① Stroke (mm)	RCS4CR-SA7C	① Stroke (mm)	RCS4CR-SA7C
50	○	450	○
100	○	500	○
150	○	550	○
200	○	600	○
250	○	650	○
300	○	700	○
350	○	750	○
400	○	800	○

### ② Cable Length

Type	Cable Code
Standard	P(1m)
	S(3m)
	M(5m)
Specified length (Standard cable)	X06(6m) ~X10(10m)
	X11(11m)~X15(15m)
	X16(16m)~X20(20m)
Robot cable	R01(1m) ~R03(3m)
	R04(4m) ~R05(5m)
	R06(6m) ~R10(10m)
	R11(11m)~R15(15m)
	R16(16m)~R20(20m)
	R20(20m)

### ③ Options

Name	Option Code	Reference Page
Brake	<b>B</b>	See P.131
Cable exit direction (Top)	<b>CJT</b>	See P.131
Cable exit direction (Right)	<b>CJR</b>	See P.131
Cable exit direction (Left)	<b>CJL</b>	See P.131
Cable exit direction (Bottom)	<b>CJB</b>	See P.131
High-Precision specification (*1)	<b>HPR</b>	See P.134
Non-motor end specification	<b>NM</b>	See P.136
Air suction joint in opposite position	<b>VR</b>	See P.137
Double slide specification (*2)	<b>W</b>	See P.137

(\*1) When the lead is 24, it cannot be selected. Double slider specification cannot be selected.  
(\*2) Some leads cannot be selected. (Please see P. 150)

### Actuator Specifications

Item	Description
Drive system	Ball screw φ12mm, rolled C10
Positioning repeatability (*1)	±0.01mm [±0.005mm]
Lost motion	0.1 mm or less
Base	Material: Aluminum with white alumite treatment
Allowable static moment	Ma direction 115N-m, Mb direction 115N-m, Mc direction 229N-m
Allowable dynamic moment (*2)	Ma direction 44.7N-m, Mb direction 44.7N-m, Mc direction 89.1N-m
Cleanliness	Class 10 (Fed.Std.209D), class 2.5 or equivalent (ISO 14644-1 Standard)
Ambient operating temp. & humidity	0~40°C, 85% RH or less (Non-condensing)

\* Reference for overhang load length: Ma direction: 300mm or less, Mb, Mc direction: 300mm or less

(\*1) Values in [ ] are for high precision (for lead 4/8/16) specification.  
(\*2) Assumes a standard rated life of 5,000km. The running life will vary depending on operation and installation conditions. Please contact IAI America for details of the running life.  
See page 146 for moment load directions.  
If the moment loads in Ma/Mb/Mc are within the allowable ranges, there is no overhang length limit.



CAD drawings can be downloaded from our website.  
www.intelligentactuator.com



\*1 When the slider is returning to its home position, please be careful of interference from surrounding objects, as it will travel until it reaches the M.E.  
M.E: Mechanical end S.E: Stroke end

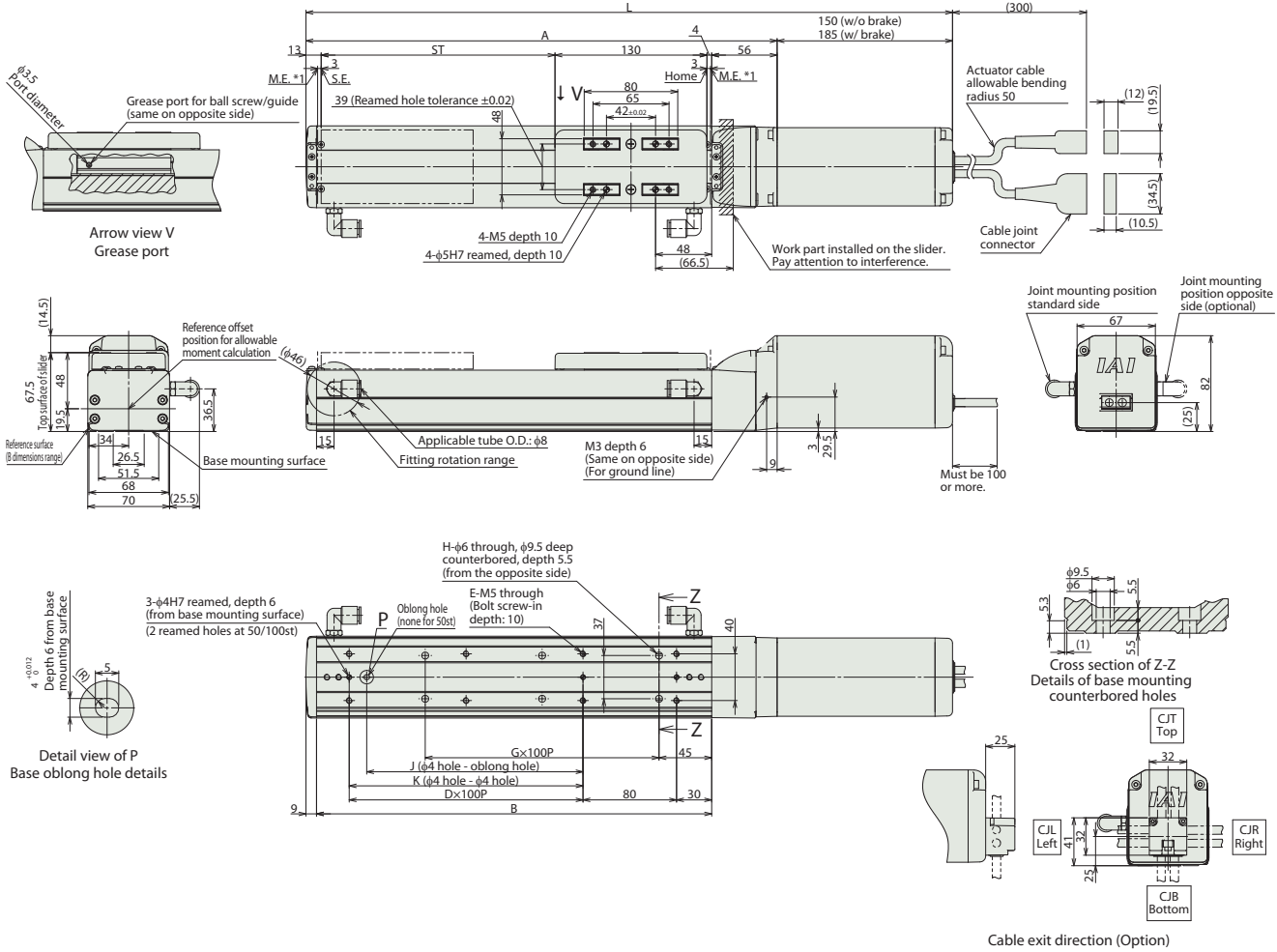

■ Dimensions and Mass by Stroke

L	Stroke	50	100	150	200	250	300	350	400	450	500	550	600	650	700	750	800
		W/o brake	403	453	503	553	603	653	703	753	803	853	903	953	1003	1053	1103
	W/ brake	438	488	538	588	638	688	738	788	838	888	938	988	1038	1088	1138	1188
	A	253	303	353	403	453	503	553	603	653	703	753	803	853	903	953	1003
	B	188	238	288	338	388	438	488	538	588	638	688	738	788	838	888	938
	D	0	1	1	2	2	3	3	4	4	5	5	6	6	7	7	8
	E	4	6	6	8	8	10	10	12	12	14	14	16	16	18	18	20
	G	1	1	2	2	3	3	4	4	5	5	6	6	7	7	8	8
	H	4	4	6	6	8	8	10	10	12	12	14	14	16	16	18	18
	J	0	85	85	185	185	285	285	385	385	485	485	585	585	685	685	785
	K	0	0	100	200	200	300	300	400	400	500	500	600	600	700	700	800
Mass (kg)	W/o brake	3.5	3.8	4.0	4.3	4.5	4.7	5.0	5.2	5.4	5.7	5.9	6.1	6.4	6.6	6.8	7.1
	W/ brake	4	4.3	4.5	4.8	5	5.2	5.5	5.7	5.9	6.2	6.4	6.6	6.9	7.1	7.3	7.6

Applicable Controllers

The RCS4 series actuators can be operated by the controllers indicated below. Please select the type depending on your intended use.

Name	External view	Max. number of connectable axes	Input power	Control method				Maximum number of positioning points	Reference page	
				Positioner	Pulse train	Program	Network * Option			
SCON-CB/CGB		1	Single phase 100V/200VAC	●	●	—	DeviceNet CC-Link CC-Link IE CompoNet MECHATROLINK EtherCAT EtherNet/IP	512 (768 for network spec.)	Please contact IAI for more information.	
SCON-LC/LCG		1		—	—	●		512 (768 for network spec.)		
SCON-CAL/CGAL		1		●	—	—		512 (768 for network spec.)		
MSCON-C		6		This model is network-compatible only.				256		
SSEL-CS		2		●	—	●		20000		
XSEL-P/Q/RA/SA		8	Single phase 200VAC Three-phase 200VAC	—	—	●	55000 (Depending on the type)			

Note: The type of compatible networks will vary depending on the controller. Please refer to the reference page for more information.

Foreword  
Slider Type  
Wide Slider Type  
Rod Type  
Radial Cylinder  
Wide Radial Cylinder  
Table Type  
Cleanroom Slider  
Cleanroom Wide Slider  
Options  
Reference Data  
Controller

# RCS4CR-SA8C



## Model Specification Items

<b>RCS4CR</b>	<b>SA8C</b>	<b>WA</b>	<b>400</b>			<b>T2</b>		
Series	Type	Encoder Type	Motor Type	Lead	Stroke	Applicable Controllers	Cable Length	Options
		WA: Battery-less Absolute	400: Servo motor 400W	20:20mm 10:10mm 5: 5mm	50:50mm 1100:1100mm (50mm increments)	T2:SCON SSEL XSEL-P/Q XSEL-RA/SA	N : None P : 1m S : 3m M : 5m X□ : Specified Length R□ : Robot Cable	Refer to Options table below.

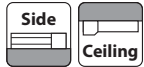

\* Depending on the model, there may be some limitations to using the vertical, side, and ceiling mount positions. Please refer to the Selection Notes on P.138 for more information.



- (1) Longer strokes may cause the maximum speed to decrease due to resonance of the ball screw. Be sure to check the maximum speed of the desired stroke in the Actuator Specifications table, which can be found below.
- (2) Both the horizontal and vertical payloads assume operation at an acceleration of 0.3G.
- (3) When the acceleration is increased, the payload will be reduced. Please refer to "Table of Payload by Acceleration" on P.139 for more details.
- (4) Estimated allowable duty varies depending on operating conditions (payload, acceleration/deceleration, etc.). Please refer to P. 149 for more information.

## Actuator Specifications

### Lead and Payload

Model Number	Motor wattage (W)	Lead (mm)	Max. payload (kg)	Rated thrust (N)	Stroke (mm)
RCS4CR-SA8C-WA-400-20-①-T2-②-③	400	20	60	339	50~1100 (50mm increments)
RCS4CR-SA8C-WA-400-10-①-T2-②-③		10	80	678	
RCS4CR-SA8C-WA-400-5-①-T2-②-③		5	90	1357	

Legend: ① Stroke ② Cable Length ③ Option

### Stroke and Max Speed/Suction Amount

(Unit: mm/s)

Stroke (mm)	Lead											Suction amount (N/min)
	50~600 (50mm increments)	650 (mm)	700 (mm)	750 (mm)	800 (mm)	850 (mm)	900 (mm)	950 (mm)	1000 (mm)	1050 (mm)	1100 (mm)	
20	1200	1090	960	860	770	695	630	570	520	480	440	160
10	600	540	480	430	385	345	310	285	260	235	220	80
5	300	270	240	215	190	175	155	140	130	120	110	40

### ① Stroke

① Stroke (mm)	RCS4CR-SA8C	① Stroke (mm)	RCS4CR-SA8C
50	○	600	○
100	○	650	○
150	○	700	○
200	○	750	○
250	○	800	○
300	○	850	○
350	○	900	○
400	○	950	○
450	○	1000	○
500	○	1050	○
550	○	1100	○

### ② Cable Length

Type	Cable Code
Standard	P(1m)
	S(3m)
	M(5m)
Specified length (Standard cable)	X06(6m) ~X10(10m)
	X11(11m)~X15(15m)
	X16(16m)~X20(20m)
	R01(1m) ~R03(3m)
Robot cable	R04(4m) ~R05(5m)
	R06(6m) ~R10(10m)
	R11(11m)~R15(15m)
	R16(16m)~R20(20m)

### ③ Options

Name	Option Code	Reference Page
Brake	B	See P.131
Cable exit direction (Top)	CJT	See P.131
Cable exit direction (Right)	CJR	See P.131
Cable exit direction (Left)	CJL	See P.131
Cable exit direction (Bottom)	CJB	See P.131
High-Precision specification (*1)	HPR	See P.134
Non-motor end specification	NM	See P.136
Air suction joint in opposite position	VR	See P.137
Double slide specification (*2)	W	See P.137

(\*1) Double slider specification cannot be selected.

(\*2) Some leads cannot be selected. (Please see P. 150)

### Actuator Specifications

Item	Description
Drive system	Ball screw φ16mm, rolled C10
Positioning repeatability (*1)	±0.01mm [±0.005mm]
Lost motion	0.1mm or less
Base	Material: Aluminum with white alumite treatment
Allowable static moment	Ma direction 219N·m, Mb direction 219N·m, Mc direction 414N·m
Allowable dynamic moment (*2)	Ma direction 77.0N·m, Mb direction 77.0N·m, Mc direction 146N·m
Cleanliness	Class 10 (Fed.Std.209D), class 2.5 or equivalent (ISO 14644-1 Standard)
Ambient operating temp. & humidity	0~40°C, 85% RH or less (Non-condensing)

\* Reference for overhang load length: Ma direction: 400mm or less, Mb, Mc direction: 400mm or less

(\*1) Values in [ ] are for high precision (for lead 5/10/20) specification.

(\*2) Assumes a standard rated life of 5,000km. The running life will vary depending on operation and installation conditions. Please contact IAI America for details of the running life.

See page 146 for moment load directions.

If the moment loads in Ma/Mb/Mc are within the allowable ranges, there is no overhang length limit.



# RCS4CR-WSA10C



Model Specification Items	<b>RCS4CR</b> — <b>WSA10C</b> — <b>WA</b> — <b>60</b> — [ ] — [ ] — [ ] — <b>T2</b> — [ ] — [ ]
	Series — Type — Encoder Type — Motor Type — Lead — Stroke — Applicable Controllers — Cable Length — Options
	WA: Battery-less Absolute      60: Servo motor 60W      16: 16mm 10: 10mm 5: 5mm 2.5: 2.5mm      50: 50mm 500: 500mm (50mm increments)      T2: SCON MSCON SSEL XSEL-P/Q XSEL-RA/SA      N: None P: 1m S: 3m M: 5m X [ ] : Specified Length R [ ] : Robot Cable      Refer to Options table below. * Be sure to select an option for the cable exit direction.

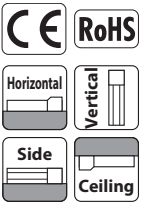

\* Depending on the model, there may be some limitations to using the vertical, side, and ceiling mount positions. Please refer to the Selection Notes on P.138 for more information.

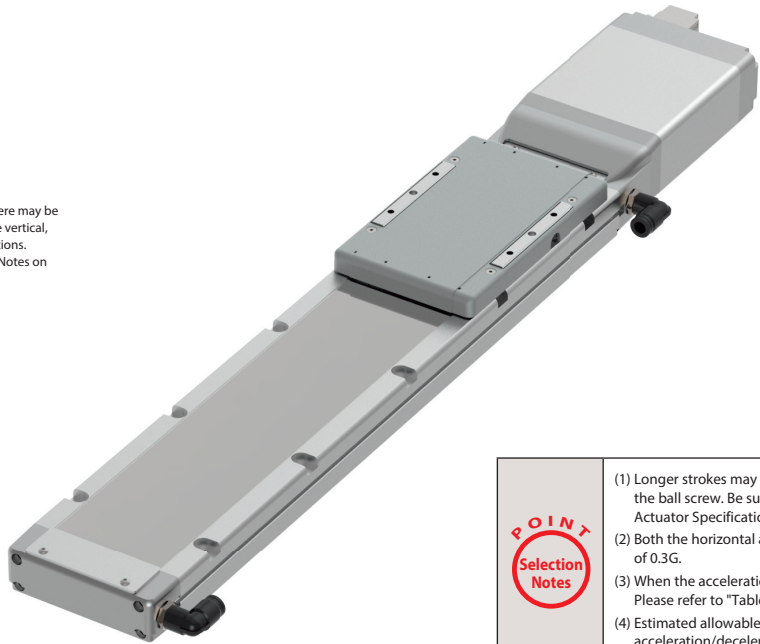

- POINT Selection Notes**
- (1) Longer strokes may cause the maximum speed to decrease due to resonance of the ball screw. Be sure to check the maximum speed of the desired stroke in the Actuator Specifications table, which can be found below.
  - (2) Both the horizontal and vertical payloads assume operation at an acceleration of 0.3G.
  - (3) When the acceleration is increased, the payload will be reduced. Please refer to "Table of Payload by Acceleration" on P.139 for more details.
  - (4) Estimated allowable duty varies depending on operating conditions (payload, acceleration/deceleration, etc.). Please refer to P. 149 for more information.

## Actuator Specifications

### Lead and Payload

Model Number	Motor wattage (W)	Lead (mm)	Max. payload		Rated thrust (N)	Stroke (mm)
			Horizontal (kg)	Vertical (kg)		
RCS4CR-WSA10C-WA-60-16-①-T2-②-③	60	16	7	—	53	50~500 (50mm increments)
RCS4CR-WSA10C-WA-60-10-①-T2-②-③		10	16	3	85	
RCS4CR-WSA10C-WA-60-5-①-T2-②-③		5	27	5	170	
RCS4CR-WSA10C-WA-60-2.5-①-T2-②-③		2.5	40	10	340	

Legend: ① Stroke ② Cable Length ③ Option

### Stroke and Max Speed/Suction Amount (Unit: mm/s)

Lead	Stroke	50~350 (50mm increments)					Suction amount (NL/min)
		400 (mm)	450 (mm)	500 (mm)	500 (mm)		
16	960	930	775	660	105		
10	600	590	490	415	60		
5	300	290	245	205	30		
2.5	150	145	120	100	25		

### ① Stroke

① Stroke (mm)	RCS4CR-WSA10C	① Stroke (mm)	RCS4CR-WSA10C
50	○	300	○
100	○	350	○
150	○	400	○
200	○	450	○
250	○	500	○

### ② Cable Length

Type	Cable Code
Standard	P(1m)
	S(3m)
	M(5m)
Specified length (Standard cable)	X06(6m) ~ X10(10m)
	X11(11m) ~ X15(15m)
	X16(16m) ~ X20(20m)
Robot cable	R01(1m) ~ R03(3m)
	R04(4m) ~ R05(5m)
	R06(6m) ~ R10(10m)
	R11(11m) ~ R15(15m)
	R16(16m) ~ R20(20m)
	R16(16m) ~ R20(20m)

### ③ Options

Name	Option Code	Reference Page
Brake	B	See P.131
Cable exit direction (Top)	CJT	See P.131
Cable exit direction (Right)	CJR	See P.131
Cable exit direction (Left)	CJL	See P.131
Cable exit direction (Bottom)	CJB	See P.131
High-precision specification	HPR	See P.134
Non-motor end specification	NM	See P.136
Air suction joint in opposite position	VR	See P.137

### Actuator Specifications

Item	Description
Drive system	Ball screw φ8mm, rolled C10
Positioning repeatability (*1)	±0.01mm [±0.005mm]
Lost motion	0.1mm or less
Base	Material: Aluminum with white alumite treatment
Allowable static moment	Ma direction 271N·m, Mb direction 271N·m, Mc direction 553N·m
Allowable dynamic moment (*2)	Ma direction 65.4N·m, Mb direction 65.4N·m, Mc direction 134N·m
Cleanliness	Class 10 (Fed.Std.209D), class 2.5 or equivalent (ISO 14644-1 Standard)
Ambient operating temp. & humidity	0~40°C, 85% RH or less (Non-condensing)

\* Reference for overhang load length: Ma direction: 500mm or less, Mb, Mc direction: 500mm or less

(\*1) Values in [ ] are for high precision specification.

(\*2) Assumes a standard rated life of 5,000km. The running life will vary depending on operation and installation conditions. Please contact IAI America for details of the running life.

See page 146 for moment load directions.

If the moment loads in Ma/Mb/Mc are within the allowable ranges, there is no overhang length limit.



\*1 When the slider is returning to its home position, please be careful of interference from surrounding objects, as it will travel until it reaches the M.E.  
M.E: Mechanical end S.E: Stroke end

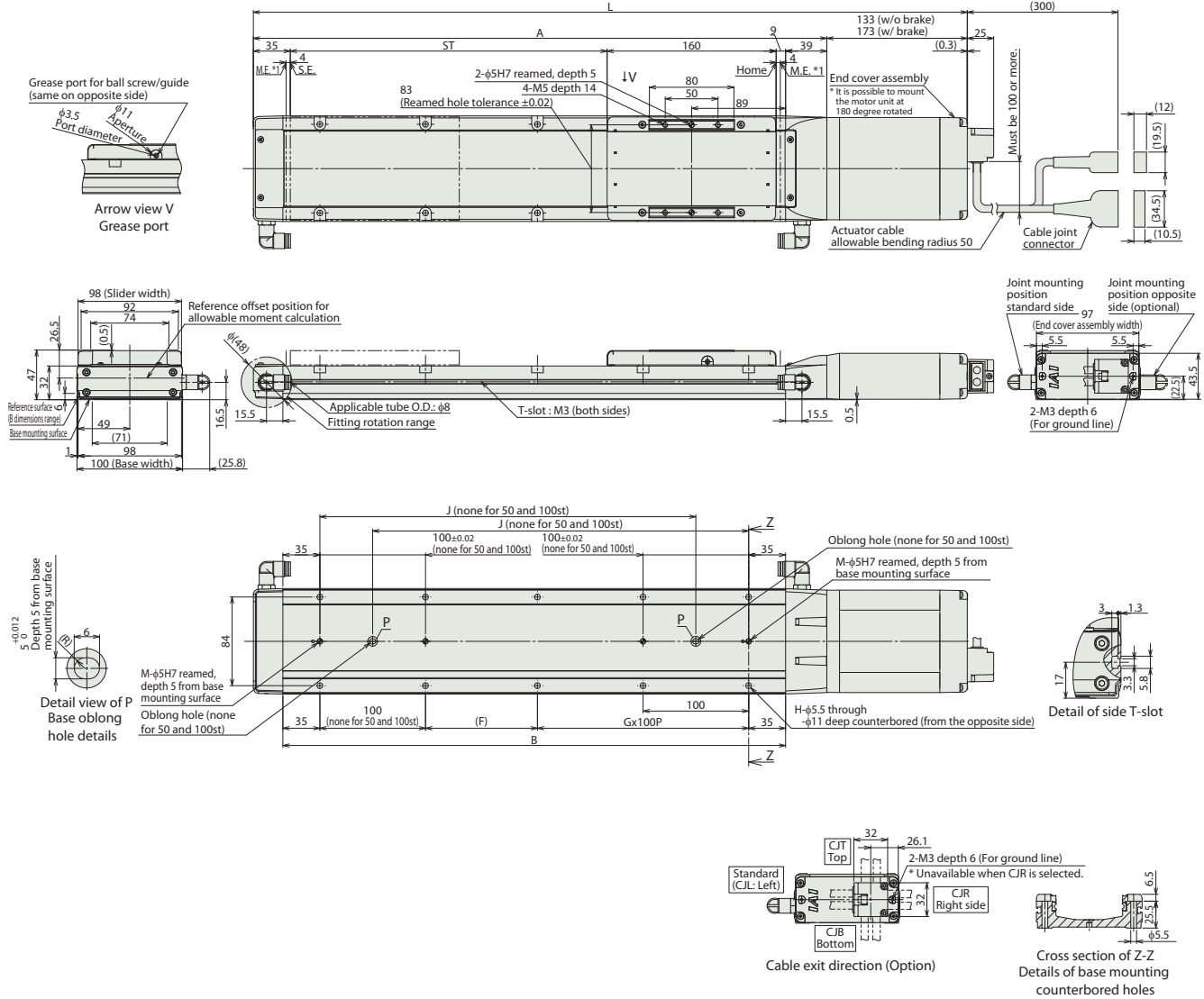

**Dimensions and Mass by Stroke**

L	Stroke	50	100	150	200	250	300	350	400	450	500
	W/o brake	426	476	526	576	626	676	726	776	826	876
W/ brake	466	516	566	616	666	716	766	816	866	916	
A	293	343	393	443	493	543	593	643	693	743	
B	226	276	326	376	426	476	526	576	626	676	
F	156	206	256	306	356	406	456	506	556		
G	0	0	1	1	2	2	3	3	4	4	
H	4	4	8	8	10	10	12	12	14	14	
J	-	-	206	256	306	356	406	456	506	556	
M	1	1	2	2	2	2	2	2	2	2	
Mass (kg)	W/o brake	2.8	3.0	3.3	3.5	3.8	4.0	4.3	4.5	4.8	5.0
	W/ brake	3.1	3.3	3.6	3.8	4.1	4.3	4.6	4.8	5.1	5.3

**Applicable Controllers**

The RCS4 series actuators can be operated by the controllers indicated below. Please select the type depending on your intended use.

Name	External view	Max. number of connectable axes	Input power	Control method				Maximum number of positioning points	Reference page	
				Positioner	Pulse train	Program	Network * Option			
SCON-CB/CGB		1	Single phase 100V/200VAC	●	●	-	DeviceNet CC-Link CompoNet MECHATROLINK EtherCAT EtherNet/IP	512 (768 for network spec.)	Please contact IAI for more information.	
SCON-LC/LCG		1		-	-	●		512 (768 for network spec.)		
SCON-CAL/CGAL		1		●	-	-		512 (768 for network spec.)		
MSCON-C		6		This model is network-compatible only.				256		
SSEL-CS		2		●	-	●		20000		
XSEL-P/Q/RA/SA		8	Single phase 200VAC Three-phase 200VAC	-	-	●	55000 (Depending on the type)			

Note: The type of compatible networks will vary depending on the controller. Please refer to the reference page for more information.

Foreword  
Slider Type  
Wide Slider Type  
Rod Type  
Radial Cylinder  
Wide Radial Cylinder  
Table Type  
Cleanroom Slider  
Cleanroom Wide Slider  
Options  
Reference Data  
Controller





\*1 When the slider is returning to its home position, please be careful of interference from surrounding objects, as it will travel until it reaches the M.E.  
M.E: Mechanical end S.E: Stroke end

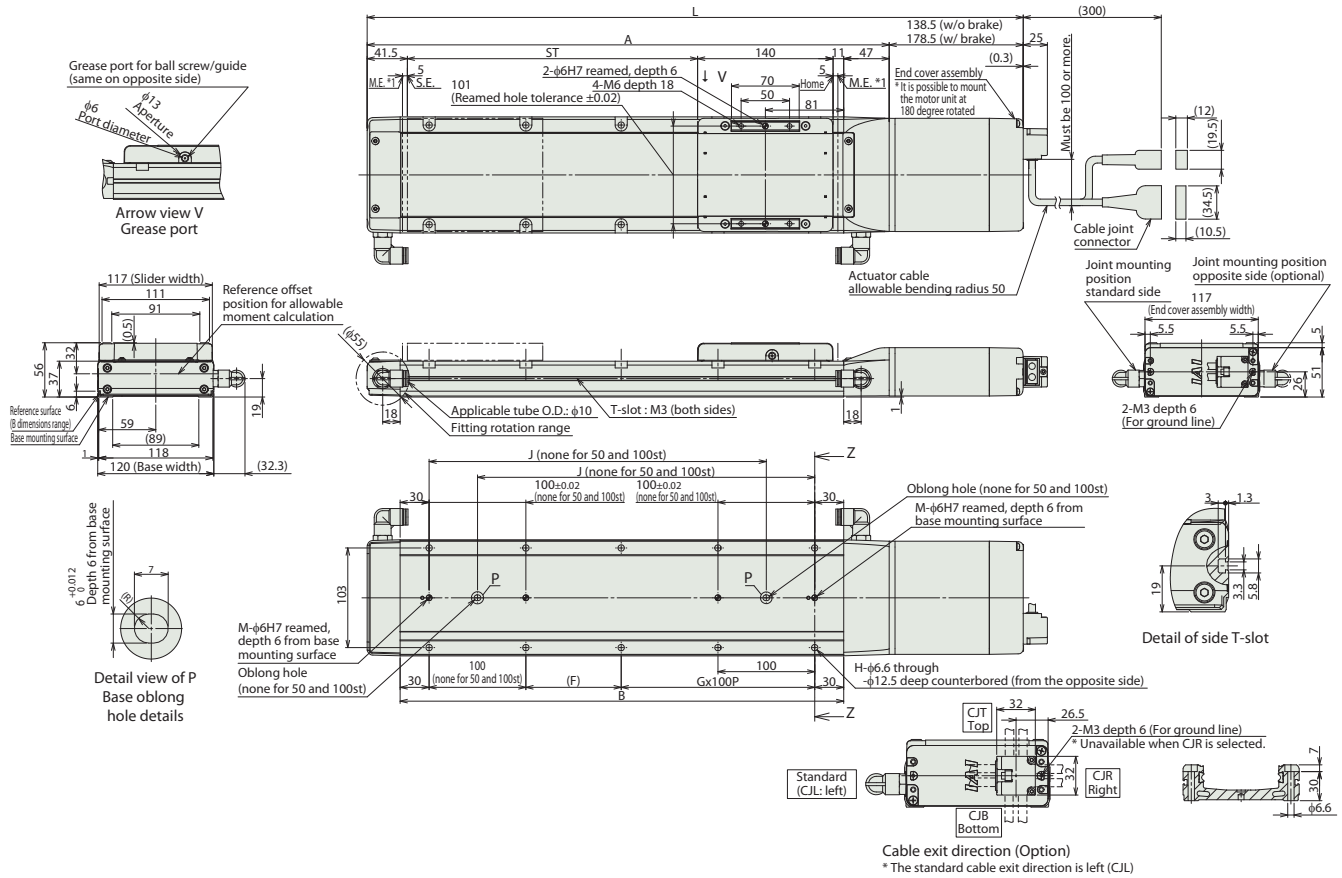

■ Dimensions and Mass by Stroke

L	Stroke	50	100	150	200	250	300	350	400	450	500	550	600	650	700	750	800
	W/o brake	428	478	528	578	628	678	728	778	828	878	928	978	1028	1078	1128	1178
W/ brake	468	518	568	618	668	718	768	818	868	918	968	1018	1068	1118	1168	1218	
A	289.5	339.5	389.5	439.5	489.5	539.5	589.5	639.5	689.5	739.5	789.5	839.5	889.5	939.5	989.5	1039.5	
B	208.5	258.5	308.5	358.5	408.5	458.5	508.5	558.5	608.5	658.5	708.5	758.5	808.5	858.5	908.5	958.5	
F	148.5	198.5	248.5	298.5	348.5	398.5	448.5	498.5	548.5	598.5	648.5	698.5	748.5	798.5	848.5		
G	0	0	1	1	2	2	3	3	4	4	5	5	6	6	7	7	
H	4	4	8	8	10	10	12	12	14	14	16	16	18	18	20	20	
J	-	-	198.5	248.5	298.5	348.5	398.5	448.5	498.5	548.5	598.5	648.5	698.5	748.5	798.5	848.5	
M	1	1	2	2	2	2	2	2	2	2	2	2	2	2	2	2	
Mass (kg)	W/o brake	3.8	4.2	4.5	4.8	5.2	5.5	5.8	6.2	6.5	6.9	7.2	7.5	7.9	8.2	8.5	8.9
	W/ brake	4.2	4.6	4.9	5.2	5.6	5.9	6.2	6.6	6.9	7.3	7.6	7.9	8.3	8.6	8.9	9.3

Applicable Controllers

The RCS4 series actuators can be operated by the controllers indicated below. Please select the type depending on your intended use.

Name	External view	Max. number of connectable axes	Input power	Control method				Maximum number of positioning points	Reference page	
				Positioner	Pulse train	Program	Network * Option			
SCON-CB/CGB		1	Single phase 100V/200VAC	●	●	-	DeviceNet CC-Link CC-Link IE CompoNet MECHATROLINK EtherCAT EtherNet/IP	512 (768 for network spec.)	Please contact IAI for more information.	
SCON-LC/LCG		1		-	-	●		512 (768 for network spec.)		
SCON-CAL/CGAL		1		●	-	-		512 (768 for network spec.)		
MSCON-C		6		This model is network-compatible only.				256		
SSEL-CS		2		●	-	●		20000		
XSEL-P/Q/RA/SA		8	Single phase 200VAC Three-phase 200VAC	-	-	●	55000 (Depending on the type)			

Note: The type of compatible networks will vary depending on the controller. Please refer to the reference page for more information.

Foreword  
Slider Type  
Wide Slider Type  
Rod Type  
Radial Cylinder  
Wide Radial Cylinder  
Table Type  
Cleanroom Slider  
Cleanroom Wide Slider  
Options  
Reference Data  
Controller







\*1 When the slider is returning to its home position, please be careful of interference from surrounding objects, as it will travel until it reaches the M.E.  
M.E: Mechanical end S.E: Stroke end

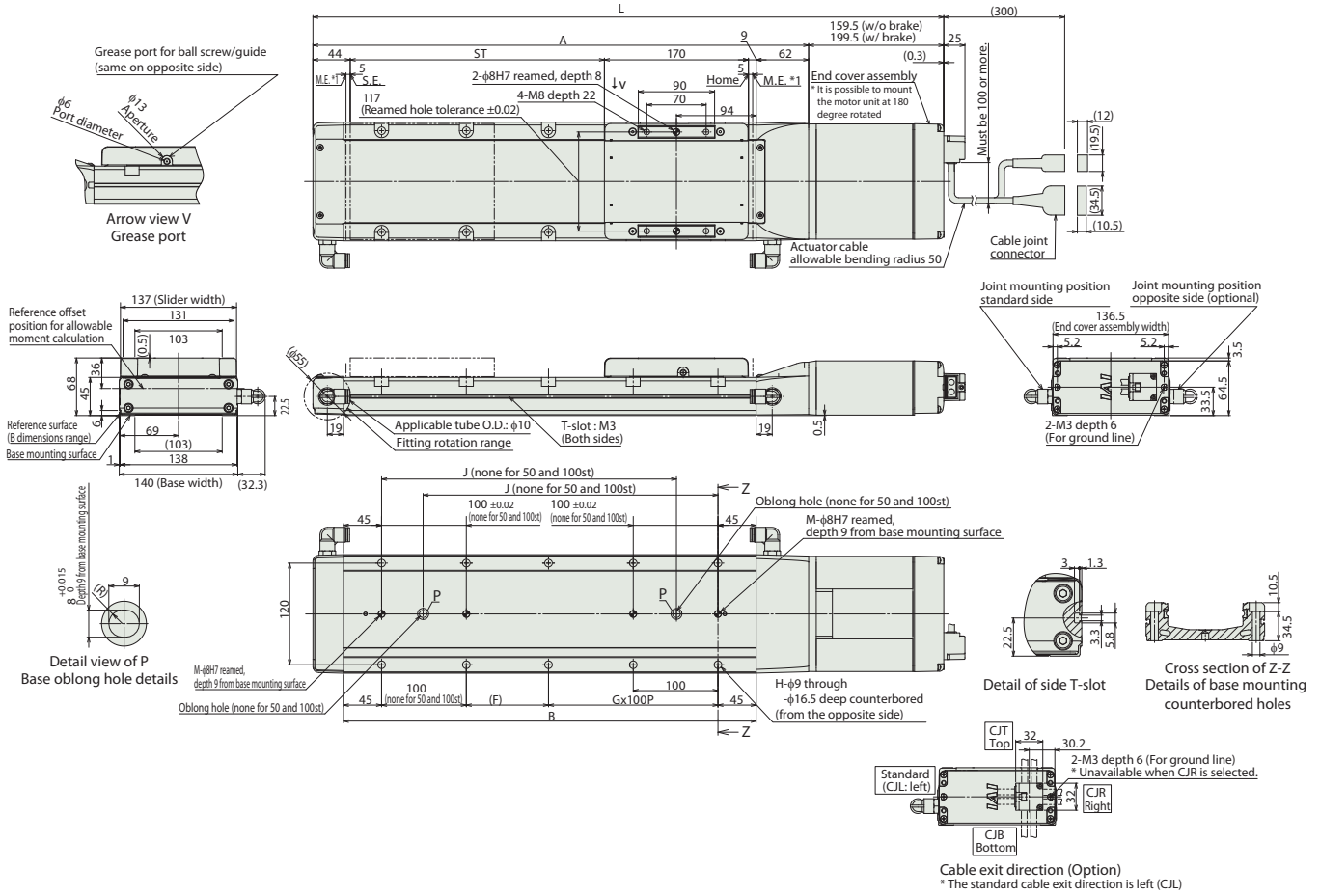

**Dimensions and Mass by Stroke**

L	Stroke	50	100	150	200	250	300	350	400	450	500	550	600	650	700	750	800
	W/o brake	494.5	544.5	594.5	644.5	694.5	744.5	794.5	844.5	894.5	944.5	994.5	1044.5	1094.5	1144.5	1194.5	1244.5
	W/ brake	534.5	584.5	634.5	684.5	734.5	784.5	834.5	884.5	934.5	984.5	1034.5	1084.5	1134.5	1184.5	1234.5	1284.5
	A	335	385	435	485	535	585	635	685	735	785	835	885	935	985	1035	1085
	B	237	287	337	387	437	487	537	587	637	687	737	787	837	887	937	987
	F	147	197	247	297	347	397	447	497	547	597	647	697	747	797	847	897
	G	0	0	1	1	2	2	3	3	4	4	5	5	6	6	7	7
	H	4	4	8	8	10	10	12	12	14	14	16	16	18	18	20	20
	J	-	-	198	248	298	348	398	448	498	548	598	648	698	748	798	848
	M	1	1	2	2	2	2	2	2	2	2	2	2	2	2	2	2
Mass (kg)	W/o brake	6.5	6.9	7.4	7.9	8.4	8.9	9.4	9.9	10.3	10.8	11.3	11.8	12.3	12.8	13.3	13.8
	W/ brake	7.1	7.5	8	8.5	9	9.5	10	10.5	10.9	11.4	11.9	12.4	12.9	13.4	13.9	14.4

**Applicable Controllers**

The RCS4 series actuators can be operated by the controllers indicated below. Please select the type depending on your intended use.

Name	External view	Max. number of connectable axes	Input power	Control method				Maximum number of positioning points	Reference page	
				Positioner	Pulse train	Program	Network * Option			
SCON-CB/CGB		1	Single phase 100V/200VAC	●	●	-	DeviceNet CC-Link CANopen CompoNet MECHATROLINK EtherCAT EtherNet/IP	512 (768 for network spec.)	Please contact IAI for more information.	
SCON-LC/LCG		1		-	-	●		512 (768 for network spec.)		
SCON-CAL/CGAL		1		●	-	-		512 (768 for network spec.)		
MSCON-C		6		This model is network-compatible only.				256		
SSEL-CS		2		●	-	●		20000		
XSEL-P/Q/RA/SA		8	Single phase 200VAC Three-phase 200VAC	-	-	●	55000 (Depending on the type)			

Note: The type of compatible networks will vary depending on the controller. Please refer to the reference page for more information.

Foreword  
Slider Type  
Wide Slider Type  
Rod Type  
Radial Cylinder  
Wide Radial Cylinder  
Table Type  
Cleanroom Slider  
Cleanroom Wide Slider  
Options  
Reference Data  
Controller

# RCS4CR-WSA16C



## Model Specification Items

**RCS4CR** — **WSA16C** — **WA** — **400** — **T2**

Series — Type — Encoder Type — Motor Type — Lead — Stroke — Applicable Controllers — Cable Length — Options

WA: Battery-less Absolute

400: Servo motor 400W

20:20mm  
10:10mm  
5: 5mm

50:50mm  
1100:1100mm  
(50mm increments)

T2:SCON  
SSEL  
XSEL-P/Q  
XSEL-RA/SA

N : None  
P : 1m  
S : 3m  
M : 5m

Refer to Options table below.  
\* Be sure to select an option for the cable exit direction.

X□□ : Specified Length  
R□□ : Robot Cable

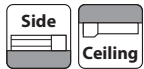

\* Depending on the model, there may be some limitations to using the vertical, side, and ceiling mount positions. Please refer to the Selection Notes on P.138 for more information.

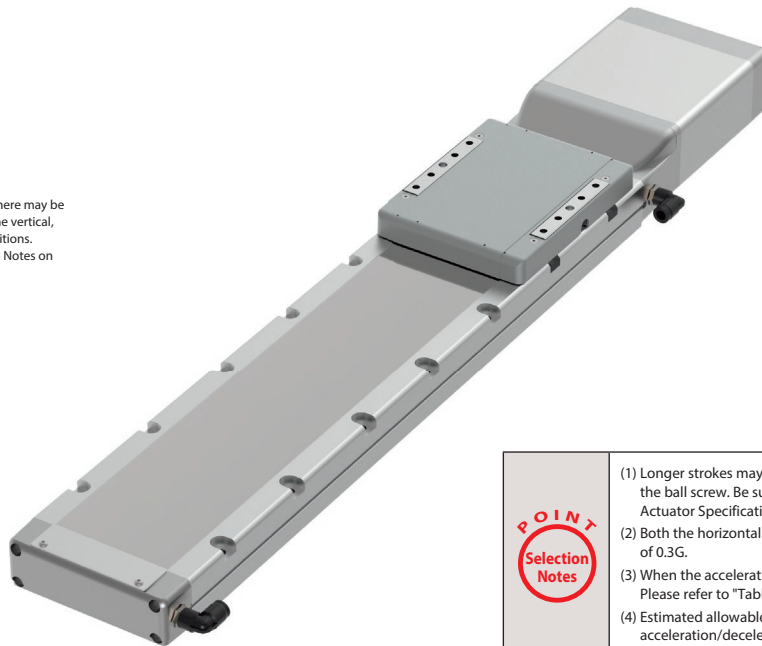

- (1) Longer strokes may cause the maximum speed to decrease due to resonance of the ball screw. Be sure to check the maximum speed of the desired stroke in the Actuator Specifications table, which can be found below.
- (2) Both the horizontal and vertical payloads assume operation at an acceleration of 0.3G.
- (3) When the acceleration is increased, the payload will be reduced. Please refer to "Table of Payload by Acceleration" on P.139 for more details.
- (4) Estimated allowable duty varies depending on operating conditions (payload, acceleration/deceleration, etc.). Please refer to P. 149 for more information.

## Actuator Specifications

### Lead and Payload

Model Number	Motor wattage (W)	Lead (mm)	Max. payload		Rated thrust (N)	Stroke (mm)
			Horizontal (kg)	Vertical (kg)		
RCS4CR-WSA16C-WA-400-20-①-T2-②-③	400	20	60	20	339	50~1100 (50mm increments)
RCS4CR-WSA16C-WA-400-10-①-T2-②-③		10	80	35	678	
RCS4CR-WSA16C-WA-400-5-①-T2-②-③		5	100	50	1357	

Legend: ① Stroke ② Cable Length ③ Option

### Stroke and Max Speed/Suction Amount

(Unit: mm/s)

Stroke	Lead												
	50~50 (50mm increments)	600 (mm)	650 (mm)	700 (mm)	750 (mm)	800 (mm)	850 (mm)	900 (mm)	950 (mm)	1000 (mm)	1050 (mm)	1100 (mm)	Suction amount (N/2mm)
20	1200	1120	990	880	780	715	645	590	535	490	450	415	130
10	600	560	490	440	395	355	320	290	265	240	225	205	80
5	300	280	240	220	195	175	160	145	130	120	110	100	50

### ① Stroke

① Stroke (mm)	RCS4CR-WSA16C	① Stroke (mm)	RCS4CR-WSA16C
50	○	600	○
100	○	650	○
150	○	700	○
200	○	750	○
250	○	800	○
300	○	850	○
350	○	900	○
400	○	950	○
450	○	1000	○
500	○	1050	○
550	○	1100	○

### ② Cable Length

Type	Cable Code
Standard	P(1m)
	S(3m)
	M(5m)
Specified length (Standard cable)	X06(6m) ~X10(10m)
	X11(11m)~X15(15m)
	X16(16m)~X20(20m)
Robot cable	R01(1m) ~R03(3m)
	R04(4m) ~R05(5m)
	R06(6m) ~R10(10m)
	R11(11m)~R15(15m)
	R16(16m)~R20(20m)

### ③ Options

Name	Option Code	Reference Page
Brake	B	See P.131
Cable exit direction (Top)	CJT	See P.131
Cable exit direction (Right)	CJR	See P.131
Cable exit direction (Left)	CJL	See P.131
Cable exit direction (Bottom)	CJB	See P.131
High-precision specification	HPR	See P.134
Non-motor end specification	NM	See P.136
Air suction joint in opposite position	VR	See P.137

### Actuator Specifications

Item	Description
Drive system	Ball screw φ16mm, rolled C10
Positioning repeatability (*1)	±0.01mm [±0.005mm]
Lost motion	0.1mm or less
Base	Material: Aluminum with white alumite treatment
Allowable static moment	Ma direction 642N·m, Mb direction 642N·m, Mc direction 1610N·m
Allowable dynamic moment (*2)	Ma direction 161N·m, Mb direction 161N·m, Mc direction 404N·m
Cleanliness	Class 10 (Fed.Std.209D), class 2.5 or equivalent (ISO 14644-1 Standard)
Ambient operating temp. & humidity	0~40°C, 85% RH or less (Non-condensing)

\* Reference for overhang load length: Ma direction: 650mm or less, Mb, Mc direction: 650mm or less

(\*1) Values in [ ] are for high precision (for lead 5/10/20) specification.

(\*2) Assumes a standard rated life of 5,000km. The running life will vary depending on operation and installation conditions. Please contact IAI America for details of the running life.

See page 146 for moment load directions.

If the moment loads in Ma/Mb/Mc are within the allowable ranges, there is no overhang length limit.



\*1 When the slider is returning to its home position, please be careful of interference from surrounding objects, as it will travel until it reaches the M.E.  
M.E: Mechanical end S.E: Stroke end

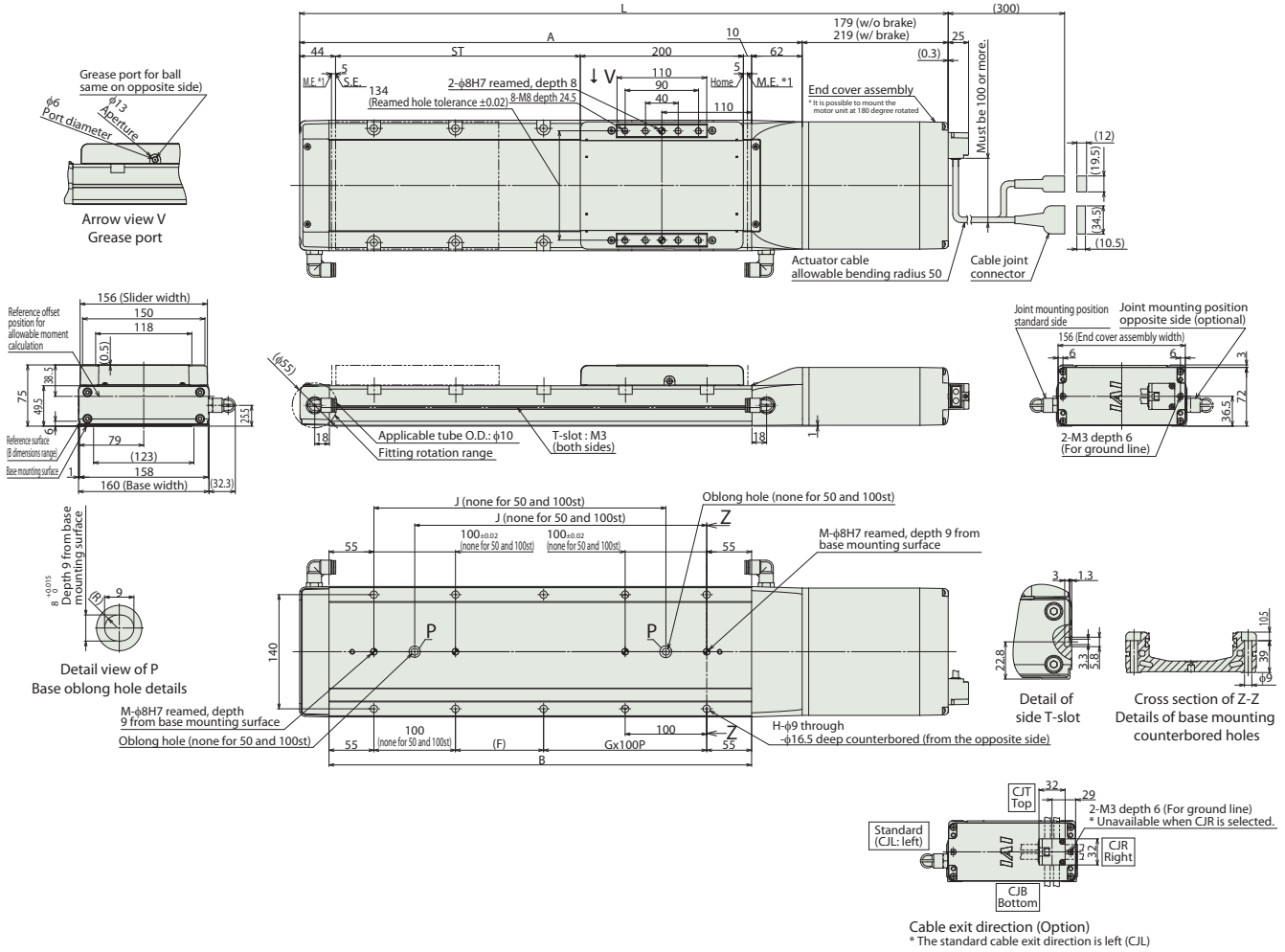

■ Dimensions and Mass by Stroke

L	Stroke	50	100	150	200	250	300	350	400	450	500	550	600	650	700	750	800	850	900	950	1000	1050	1100
		W/o brake	545	595	645	695	745	795	845	895	945	995	1045	1095	1145	1195	1245	1295	1345	1395	1445	1495	1545
W/ brake	585	635	685	735	785	835	885	935	985	1035	1085	1135	1185	1235	1285	1335	1385	1435	1485	1535	1585	1635	
A	366	416	466	516	566	616	666	716	766	816	866	916	966	1016	1066	1116	1166	1216	1266	1316	1366	1416	
B	268	318	368	418	468	518	568	618	668	718	768	818	868	918	968	1018	1068	1118	1168	1218	1268	1318	
F	158	208	258	308	358	408	458	508	558	608	658	708	758	808	858	908	958	1008	1058	1108	1158		
G	0	0	1	1	2	2	3	3	4	4	5	5	6	6	7	7	8	8	9	9	10	10	
H	4	4	8	8	10	10	12	12	14	14	16	16	18	18	20	20	22	22	24	24	26	26	
J	-	-	208	258	308	358	408	458	508	558	608	658	708	758	808	858	908	958	1008	1058	1108	1158	
M	1	1	2	2	2	2	2	2	2	2	2	2	2	2	2	2	2	2	2	2	2	2	
Mass (kg)	W/o brake	9.1	9.8	10.4	11.0	11.6	12.2	12.8	13.4	14.0	14.7	15.3	15.9	16.5	17.1	17.7	18.3	18.9	19.5	20.2	20.8	21.4	22.0
	W/ brake	9.7	10.4	11.0	11.6	12.2	12.8	13.4	14.0	14.6	15.3	15.9	16.5	17.1	17.7	18.3	18.9	19.5	20.2	20.8	21.4	22.0	22.6

Applicable Controllers

The RCS4 series actuators can be operated by the controllers indicated below. Please select the type depending on your intended use.

Name	External view	Max. connections Max. number of controlled axes	Input power	Control method				Maximum number of positioning points	Reference page
				Positioner	Pulse train	Program	Network * Option		
SCON-CB/CGB		1	Single phase 200VAC	●	●	-	<b>DeviceNet</b> <b>CC-Link</b> <b>PROFINET</b> <b>CompoNet</b> <b>MECHATROLINK</b> <b>EtherCAT</b> <b>EtherNet/IP</b> Note: The type of compatible networks will vary depending on the controller. Please refer to the reference page for more information.	512 (768 for network spec.)	Please contact IAI for more information.
SCON-LC/LCG		1		-	-	●		512 (768 for network spec.)	
SSEL-CS		2	Single phase 100V/200VAC	●	-	●		20000	
XSEL-P/Q/RA/SA		8	Single phase 200VAC Three-phase 200VAC	-	-	●		55000 (Depending on the type)	

Foreword  
Slider Type  
Wide Slider Type  
Rod Type  
Radial Cylinder  
Wide Radial Cylinder  
Table Type  
Cleanroom Slider  
Cleanroom Wide Slider  
Options  
Reference Data  
Controller

## Brake

**Model** B

**Description** When the actuator is mounted vertically, this works as a holding mechanism that prevents the slider, rod, or table from falling and damaging any attachments when the power or servo is turned off.

## Cable exit direction

**Model** CJT / CJR / CJL / CJB / CJO

**Description** This option allows you to change the exit direction of the motor-encoder cable to top, bottom, left, or right.

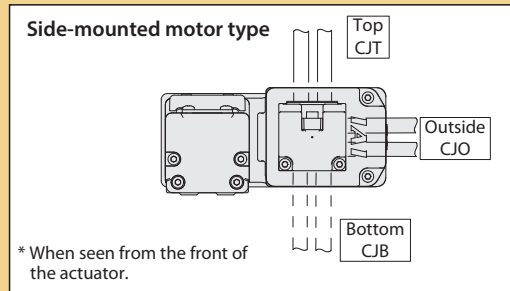
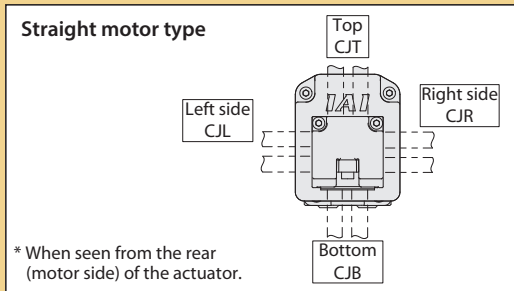

## Tip adapter (Flange)

**Model** FFA

**Description** A rod tip tooling adapter with 4 threaded holes.

RCS4-RR4□  
Model Name: RCP6-FFA-RR4

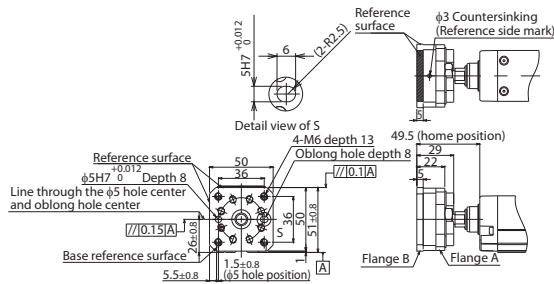

RCS4-RR6□  
Model Name: RCP6-FFA-RR6

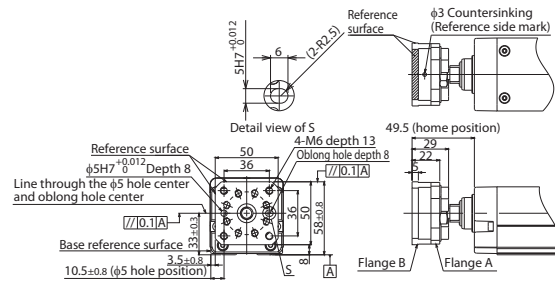

RCS4-RR7□  
Model Name: RCP6-FFA-RR7

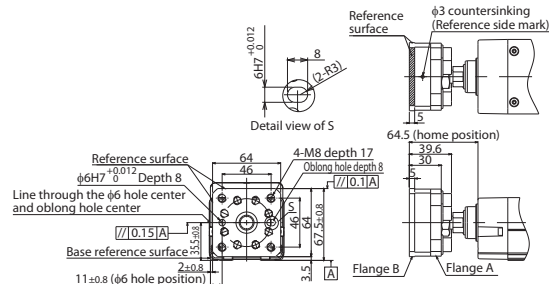



RCS4-WRA14□  
Model Name: RCP6-FL-WRA14

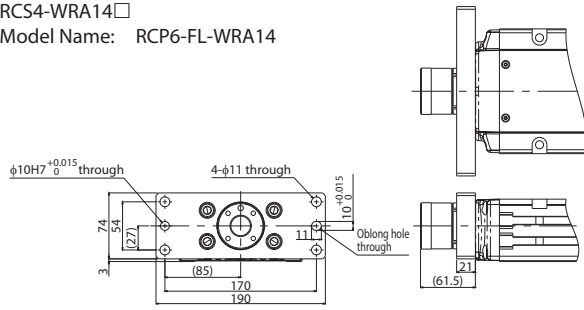

RCS4-WRA16□  
Model Name: RCP6-FL-WRA16

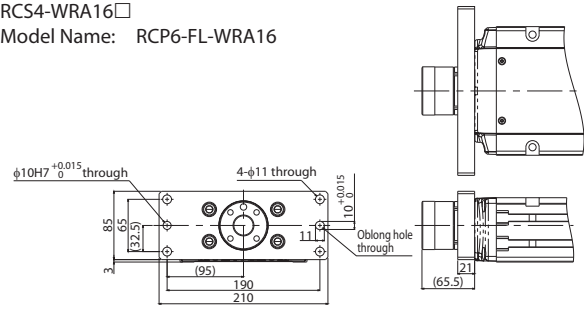

**Foot bracket**

Model **FT**

**Description** This is a bracket used to fix the actuator with bolts from the top side. (Bolts are tightened from the top, not from the bottom) For slider type actuators, when the moment load is large, please attach the foot brackets on all the mounting holes on the actuator. The actuator body may be twisted or deformed if insufficient mounting foot brackets are used. Actuator life could also be shortened. \* Refer to the installation dimensions in the actuator drawing for the installation pitch between the foot brackets.

RCS4-RA4C  
Model Name: RCP6-FT-RA4C

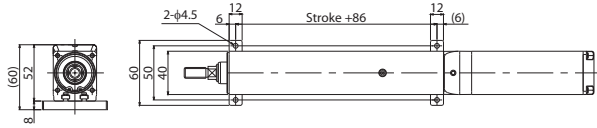

RCS4-RA6C  
Model Name: RCP6-FT-RA6C

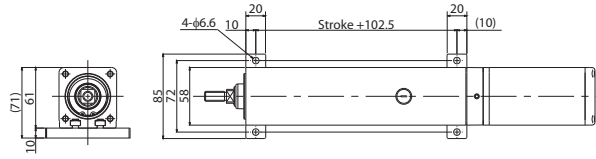

RCS4-RA7C  
Model Name: RCP6-FT-RA7C

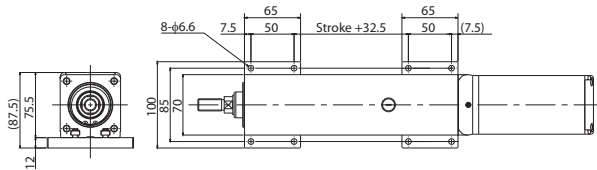

RCS4-RA8C  
Model Name: RCP6-FT-RA8C

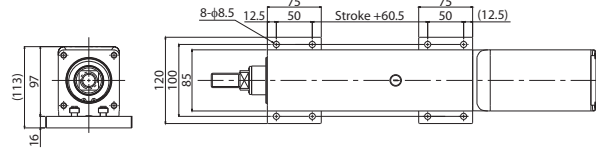

RCS4-RA4R  
Model Name: RCP6-FT-RA4R-3 (For the motor side-mounted to the right/left)

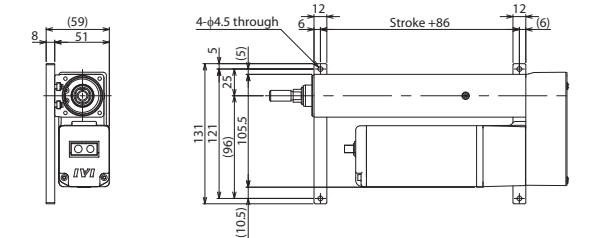

RCS4-RA6R  
Model Name: RCP6-FT-RA6R (For the motor side-mounted to the right/left)

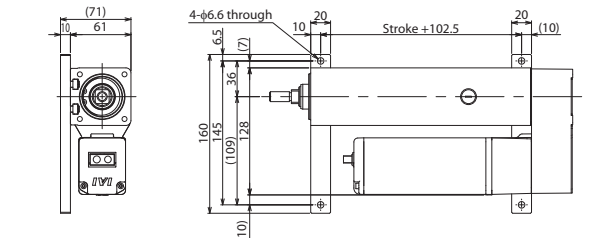

RCS4-RA7R  
Model Name: RCP6-FT-RA7R (For the motor side-mounted to the right/left)

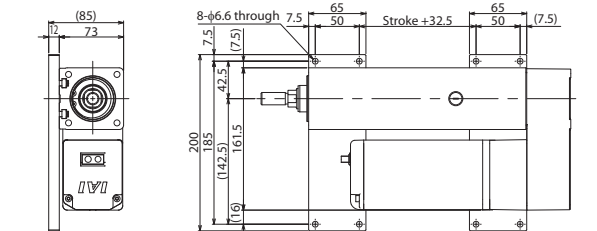

RCS4-RA8R  
Model Name: RCP6-FT-RA8R-2 (For the motor side-mounted to the right/left)

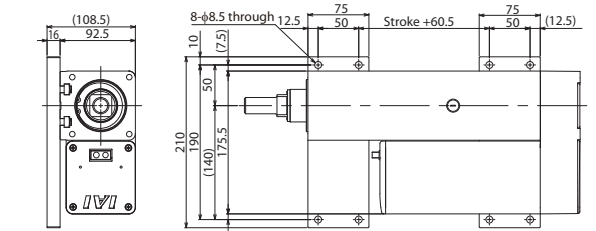

**Model** HPR

**Description** The positioning repeatability of the standard specification of the slider and wide slider types is  $\pm 0.01$  mm. If this option is selected, the positioning repeatability can be  $\pm 0.005$  mm. \* This option can be selected for actuators with lead 20 mm or less.

**Tip adapter (Keyway)**

**Model** KFA

**Description** A rod tip adapter with 1 threaded hole and a parallel keyway.

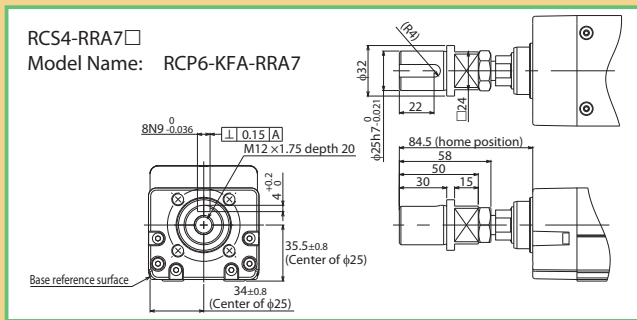
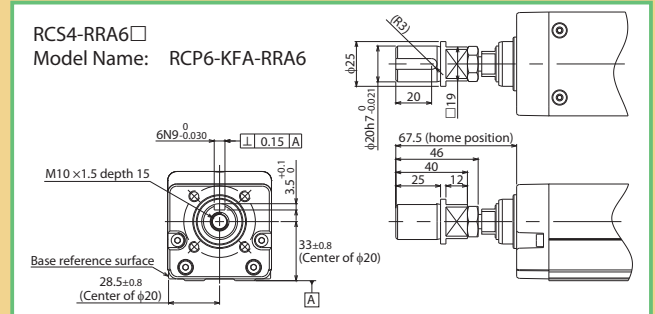
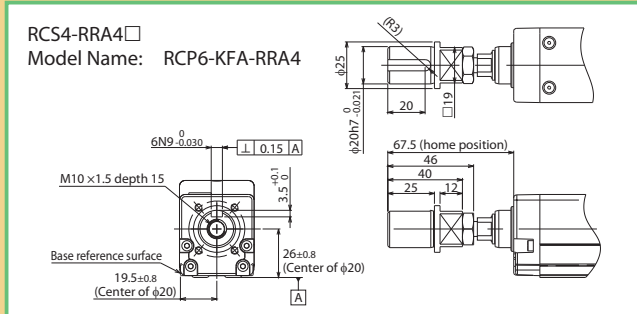

Foreword  
Slider Type  
Wide Slider Type  
Rod Type  
Radial Cylinder  
Wide Radial Cylinder  
Table Type  
Cleanroom Slider  
Cleanroom Wide Slider  
Options  
Reference Data  
Controller





Non-motor End Specification

**Model** **NM**

**Description** The standard specification home position is set by the slider, rod, and table on the motor side, but there is the option for the home position to be on the other side to accommodate variations in equipment layout, etc. (Please note that changing the home position after the actuator is manufactured and shipped from the factory may require the products to be sent back to IAI for re-setting.)

T-slot nut bar

**Model** **NTB / NTBL / NTBR**

**Description** T-slot nut bar is a bar-shaped bracket which is to be inserted into the actuator's T-slot. There are tapped mounting holes on the T-slot nut bar. From the motor-side view, NTBL is inserted on the left side, and NTBR is inserted on the right.

\* Only NTB can be selected for Rod type (RA), while either NTBL (for the actuator with its motor side-mounted to the right) or NTBR (for the actuator with its motor side-mounted to the left) can be selected for wide radial cylinder type (WRA).

RCS4-RA4□  
Model Name: RCP6-NTB-RA4

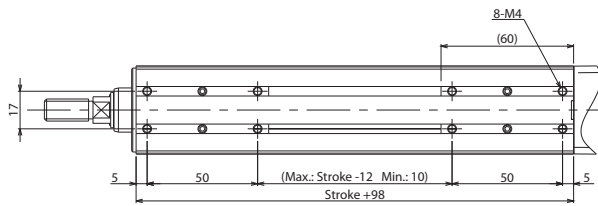

RCS4-RA6□  
Model Name: RCP6-NTB-RA6

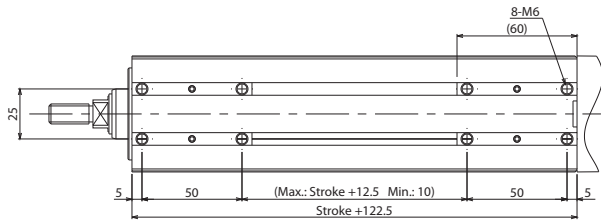

RCS4-RA7□  
Model Name: RCP6-NTB-RA7

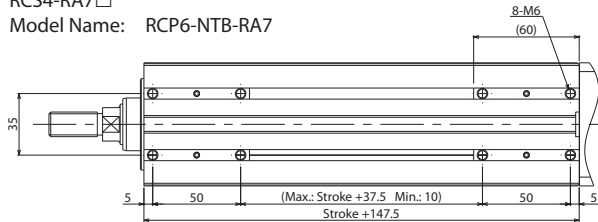

RCS4-RA8□  
Model Name: RCP6-NTB-RA8

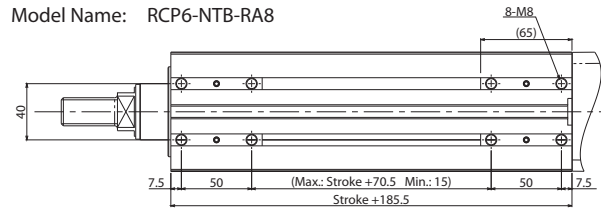

RCS4-WRA10□  
Model Name: RCP6-NTB-WRA10

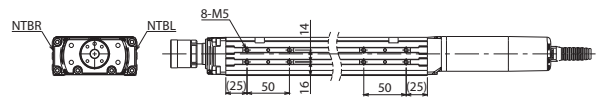

RCS4-WRA12□  
Model Name: RCP6-NTB-WRA12

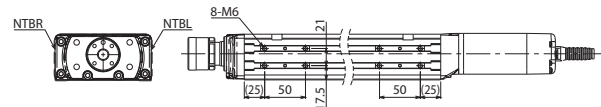

RCS4-WRA14□  
Model Name: RCP6-NTB-WRA14

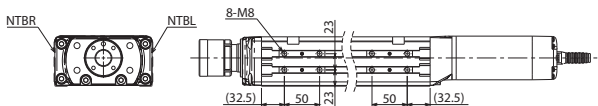

RCS4-WRA16□  
Model Name: RCP6-NTB-WRA16

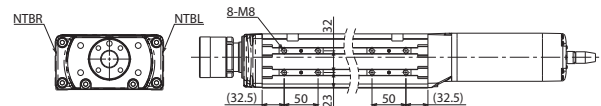

Foreword  
Slider Type  
Wide Slider Type  
Rod Type  
Radial Cylinder  
Wide Radial Cylinder  
Table Type  
Cleanroom Slider  
Cleanroom Wide Slider  
Options  
Reference Data  
Controller

## Back mounting plate

**Model** **RP**

**Description** A metal bracket (plate) for fixing the back of the side-mounted motor type to equipment.  
\* Please refer to product specification pages for drawings.

## Slider Roller Specification

**Model** **SR**

**Description** Changes the slider structure of the standard slider type to the same roller structure of the cleanroom specification.  
Changing to roller specification will make the external view and dimensions of the slider cover the same as the cleanroom specification.

## Slider spacer

**Model** **SS**

**Description** This option changes the top of the slider position to be higher than the motor height.

RCS4-SA4R  
Model Name: RCS4-SS-SA4

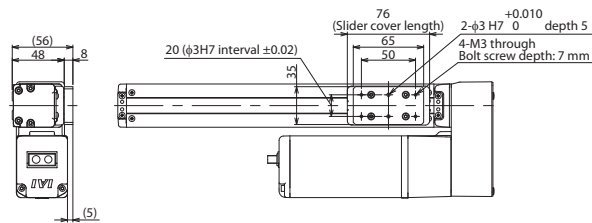

RCS4-SA7R  
Model Name: RCP6-SS-SA7

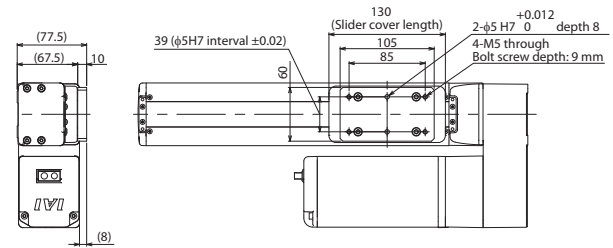

RCS4-SA8R  
Model Name: RCP6-SS-SA8

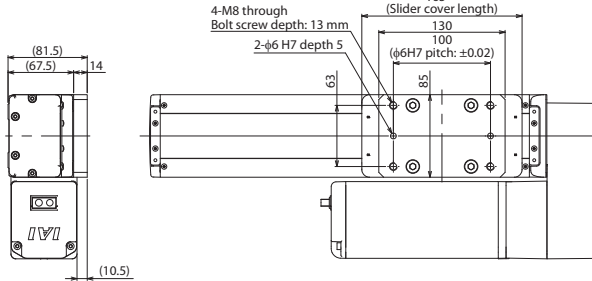

RCS4-WSA10R  
Model Name: RCS4-SS-WSA10

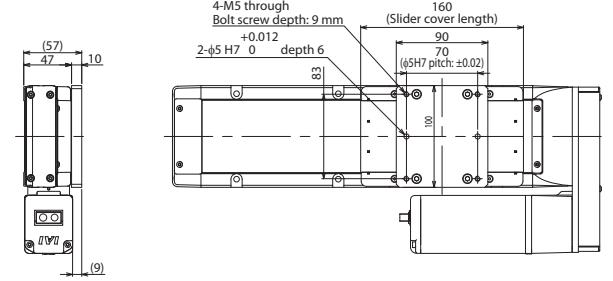

RCS4-WSA14R  
Model Name: RCS4-SS-WSA14

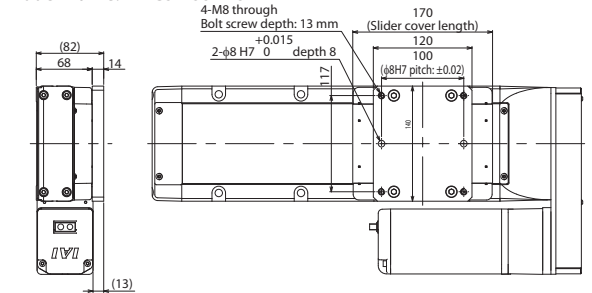

## Vacuum joint mounting position opposite

**Model** **VR**

**Description** As standard, the vacuum joint is installed on the left side of the body when seen from the motor side, but this option changes it to the right side (opposite side).

## Double Slider Specification

**Model** **W**

**Description** This option adds a free slider not connected to the ball screw or drive belt.  
Using a double slider enables increased moment and overhang load length.  
\* For the allowable dynamic moment and overhang load length of the double slider, refer to P.248.

## ■ Cautions When Selecting the Rod Attachment Option

Model	Options			Model	Options			Model	Options		
RCS4	FL	NTBL	NTBR	RCS4	FL	NTBL	NTBR	RCS4	FL	NTBL	NTBR
RA4R	①	—	—	RRA4R	③	—	—	WRA10R	②	⑥	⑦
RA6R	①	—	—	RRA6R	④	—	—	WRA12R	②	⑥	⑦
RA7R	①	—	—	RRA7R	⑤	—	—	WRA14R	②	⑥	⑦
RA8R	②	—	—	RRA8R	②	—	—	WRA16R	②	⑥	⑦

Be sure to check the following conditions when selecting options.

- ① Cannot be selected for 100st or less
- ② Cannot be selected for 50st
- ③ Cannot be selected for 110st or less
- ④ Cannot be selected for 65st
- ⑤ Cannot be selected for 70st
- ⑥ Can only be selected when MR is selected
- ⑦ Can only be selected when ML is selected

- The flange rod attachment option cannot be used on side mounting position for RCS4-RRA8R when the following strokes are selected.

· RCS4-RRA8R: 50 to 100st (standard/with brake)

## ■ Mounting Orientation

○: Can be installed △: Daily inspection required

Mounting orientation						
Classification	Series	Type	Horizontal mounting on flat surface	Vertical mounting (*1)	Side mounting	Ceiling mounting
Standard specification	RCS4	SA/WSA	○	○	△ (*2)	△ (*2)
		RA/RRA/WRA	○ (*3)	○	○	○
		TA	○	○	○	○
Cleanroom Specification	RCS4CR	SA/WSA	○	○	△ (*4)	△ (*4)

\*1. When mounting vertically, please install the motor on the top if possible. While installing the motor on the bottom will not cause problems during normal operation, long periods of inactivity may cause the grease to separate, flow into the motor unit, and cause problems on rare occasions.

\*2. While installation in the side and ceiling mount positions are available, this may cause slack or misalignment in the stainless steel sheet. Continuing to use it this way could cause the stainless steel sheet to break. Please inspect it daily and adjust the sheet if any slack or misalignment is found.

\*3. Please install a support block when front mounting or back mounting a horizontally mounted actuator. Depending on the operation/installation conditions, vibration may cause damage to the actuator body. Do not fix the side-mounted motor specification only at the back of the reverse bracket. Fix the base with a support block, etc. If the actuator will experience external force or is being used in conjunction with a Cartesian robot, etc., please use the mounting holes on the base of the actuator to secure it into place.

<Flange mount specification>

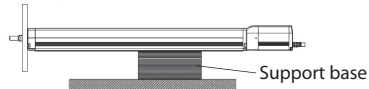

<Side-mounted motor specification>

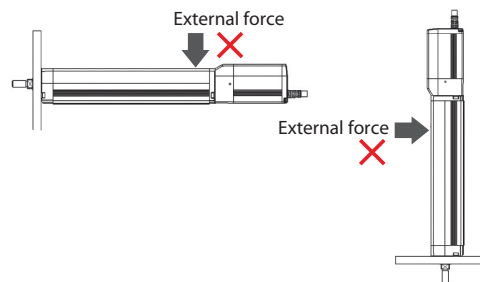
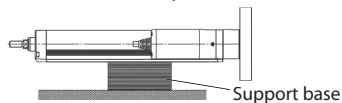

\*4. Cleanliness class 10 may not be maintained in side mounting or ceiling mounting if slack or misalignment occurs in the stainless steel sheet. Please inspect it daily and adjust the sheet if any slack or misalignment is found.

# Tables of Payload by Acceleration

The tables below show the max. payload at each acceleration/deceleration for different models. Please select a model that satisfies the operational conditions you desire.

## RCS4 horizontal position

\* RCS4CR is the same.

Series	Type	Motor wattage	Lead	Payload per Acceleration/Deceleration (kg)					
				0.2G	0.3G	0.5G	0.7G	1.0G	1.2G
RCS4	SA4C	60	2.5		20	20	20		
			5		17	17	15	15	
			10		14	14	12	10	6
			16		10	8	6	6	4
	SA6C	100	3		45	30	20		
			6		45	30	20	20	
			12		30	24	20	15	15
			20		18	15	10	8	6
	SA7C	200	30		11	6	6	4	3
			4		50	50	40		
			8		45	40	40	35	
			16		40	30	15	15	12
	SA8C	400	24		30	12	10	6	5
			36		7	7	6	4	3
			5		90	90	70		
			10		80	80	70	60	
	SA4R	60	20		60	40	30	20	15
			30		30	25	20	15	10
			48		8	8	6	5	4
			2.5		20	20	20		
	SA6R	100	5		17	17	15	13	
			10		14	14	12	10	
			16		10	8	6	6	
			3		45	30	20		
	SA7R	200	6		45	30	20	20	
			12		30	24	20	15	
			20		18	15	10	8	
			30		11	6	6	4	
	SA8R	400	4		50	50	40		
			8		45	40	40	35	
			16		38	30	15	15	
			24		30	12	10	6	
	RA4C	60	36		7	7	6	4	
			5		90	90	70		
			10		80	80	70	60	
			20		60	40	30	20	
	RA6C	100	30		30	25	20	15	
			48		8	8	6	5	
			2.5		40	40	35		
			5		30	30	25	20	
	RA7C	200	10		18	15	12	12	8
			16		8	8	6	5	4
			3		60	50	40		
			6		50	45	30	25	
	RA8C	400	12		25	20	20	12	12
			20		15	10	8	6	4
			4		80	70	60		
			8		60	50	40	40	
RA4R	60	16		45	30	25	20	15	
		24		20	15	10	10	8	
		5	100	100	80	60			
		10		80	80	70	60		
RA6R	100	20		60	40	40	25	20	
		2.5		40	40	35			
		5		30	30	25	20		
		10		18	15	12	12		
RA7R	200	16		8	8	6	5		
		3		60	50	40			
		6		50	45	30	25		
		12		25	20	20	12	12	
RA8R	400	20		15	10	8	6	4	
		4		80	70	60			
		8		60	50	40	40		
		16		45	30	25	20	15	

RCS4 horizontal position

\* RCS4CR is the same.

Series	Type	Motor wattage	Lead	Payload per Acceleration/Deceleration (kg)					
				0.2G	0.3G	0.5G	0.7G	1.0G	1.2G
RCS4	RRA4C	60	2.5		40	40	35		
			5		30	30	25	20	
			10		18	15	12	12	8
			16		8	8	6	5	4
	RRA6C	100	3		60	50	40		
			6		50	45	30	25	
			12		25	20	20	12	12
			20		15	10	8	6	4
	RRA7C	200	4		80	70	60		
			8		60	50	40	40	
			16		45	30	25	20	15
			24		20	15	10	10	8
	RRA8C	400	5	100	100	80	60		
			10		80	80	70	60	
			20		60	40	25	20	15
			30		30	20	15	10	8
	RRA4R	60	2.5		40	40	35		
			5		30	30	25	20	
			10		18	15	12	12	
			16		8	8	6	5	
	RRA6R	100	3		60	50	40		
			6		50	45	30	25	
			12		25	20	20	12	
			20		15	10	8	6	
	RRA7R	200	4		80	70	60		
			8		60	50	40	40	
			16		45	30	25	20	
			24		20	15	10	10	
	RRA8R	400	5	100	100	80	60		
			10		80	80	70	60	
			20		60	40	25	20	
			30		30	20	15	10	
	WRA10C	60	2.5		40	35	25		
			5		25	20	15	10	
			10		16	16	12	10	8
			16		5	5	4	3	2
	WRA12C	100	3		60	50	40		
			6		40	40	30	25	
			12		25	25	20	15	15
			20		12	10	8	6	4
	WRA14C	200	4		85	70	60		
			8		65	50	40	40	
			16		50	30	25	20	15
			24		25	15	10	6	4
	WRA16C	400	5		100	80	60		
			10		80	80	70	60	
			20		60	40	25	20	15
			30		30	20	15	8	6
WRA10R	60	2.5		40	35	25			
		5		25	20	15	10		
		10		13	13	9	6		
		16		5	5	4	3		
WRA12R	100	3		60	50	40			
		6		40	40	30	25		
		12		25	25	20	15		
		20		12	10	8	6		
WRA14R	200	4		85	70	60			
		8		65	50	40	40		
		16		50	30	25	20		
		24		25	15	10	6		
WRA16R	400	5		100	80	60			
		10		80	80	70	60		
		20		60	40	25	20		
		30		30	20	15	8		
WSA10C	50	2.5		40	30	18			
		5		27	27	20	18		
		10		16	16	12	12	6	
		16		7	7	5	4	3	

Foreword  
Slider Type  
Wide Slider Type  
Rod Type  
Radial Cylinder  
Wide Radial Cylinder  
Table Type  
Cleanroom Slider  
Cleanroom Wide Slider  
Options  
Reference Data  
Controller

# Tables of Payload by Acceleration

## RCS4 horizontal position

\* RCS4CR is the same.

Series	Type	Motor wattage	Lead	Payload per Acceleration/Deceleration (kg)						
				0.2G	0.3G	0.5G	0.7G	1.0G	1.2G	
RCS4	WSA12C	100	3		55	30	15			
			6		45	40	30	20		
			12		25	25	20	15	15	
			20		15	10	8	6	4	
			30		5	5	5	4	3	
	WSA14C	200	4		80	60	30			
			8		65	50	40	40		
			16		45	30	20	20	18	
			24		20	15	15	10	5	
			36		7	6	6	4	3	
	WSA16C	400	5		100	100	80			
			10		80	80	70	60		
			20		60	40	25	22	20	
			30		30	25	20	10	8	
			2.5		40	30	18			
	WSA10R	60	5		27	27	20	18		
			10		16	16	12	12		
			16		7	7	5	4		
	WSA12R	100	3		55	30	15			
			6		43	40	30	20		
			12		23	23	16	15		
			20		13	10	8	6		
	WSA14R	200	30		5	5	5	4		
			4		75	60	30			
			8		65	50	40	40		
			16		45	30	20	20		
			24		20	15	15	10		
	WSA16R	400	36		7	6	6	4		
			5		100	100	80			
			10		80	80	70	60		
			20		60	40	25	22		
			30		30	25	20	10		
	TA4C (Single)	60	2.5		5	5	5	5		
			5		5	5	5	5		
			10		5	5	5	5	5	
			16		4	4	4	4	3	
			2.5		10	10	10			
	TA4C (Double)	60	5		10	10	10	8		
			10		8	8	8	6	4	
			3		10	10	10			
	TA6C (Single)	100	6		8	8	8	8	8	
			12		8	8	8	8	8	8
			20		8	8	8	6	4	
			3		20	20	20			
			6		20	20	20	20		
	TA6C (Double)	100	12		14	14	14	14	12	
			4		15	15	15			
			8		15	15	15	15		
	TA7C (Single)	200	16		15	15	15	15	15	
			24		12	12	12	10	8	
4				30	30	30				
8				30	30	25	25			
16				25	25	20	20	15		
TA4R (Single)	60	2.5		5	5	5				
		5		5	5	5	5			
		10		5	5	5	5			
		16		4	4	4	4			
		2.5		10	10	10				
TA4R (Double)	60	5		10	10	10	8			
		10		8	8	8	6			
		3		10	10	10				
TA6R (Single)	100	6		8	8	8	8	8		
		12		8	8	8	8	8		
		20		8	8	8	6			
		3		20	20	20				
		6		20	20	20	20			
TA6R (Double)	100	12		14	14	14	14	14		
		4		15	15	15				
		8		15	15	15	15			
TA7R (Single)	200	16		15	15	15	15	15		
		24		12	12	12	10			
		4		30	30	30				
		8		30	30	25	25			
		16		25	25	20	20	15		
TA7R (Double)	200	4		15	15	15				
		8		15	15	15	15			
		16		15	15	15	15			

RCS4 vertical position

\* RCS4CR is the same.

Series	Type	Motor wattage	Lead	Payload per Acceleration/Deceleration (kg)						
				0.2G	0.3G	0.5G	0.7G	1.0G	1.2G	
RCS4	SA4C	60	2.5		12	12	10			
			5		8	8	6	6		
			10		5	5	3	3	2	
			16		3	3	1.5	1.5	1	
	SA6C	100	3		15	14	10			
			6		15	15	15	15		
			12		11	10	10	8	8	
			20		6	5	4	4	2	
	SA7C	200	30		3.5	2	2	1.5	1.5	
			4		25	25	20			
			8		20	20	20	18		
			16		12	12	10	8	8	
	SA8C	400	24		7	7	6	5	4	
			36		4	4	3	2	2	
			5		45	45	35			
			10		35	35	35	30		
	SA4R	60	20		20	20	18	15	12	
			30		12	12	10	8	6	
			2.5		12	12	10			
			5		8	8	6	6		
	SA6R	100	10		4.5	4.5	3	3		
			16		2.5	2.5	1.5	1.5		
			3		15	14	10			
			6		15	15	15	15		
	SA7R	200	12		9	9	9	8		
			20		5	5	4	4		
			30		3	2	2	1.5		
			4		25	25	20			
	SA8R	400	8		18	18	18	16		
			16		12	12	10	8		
			24		6	6	5	5		
			36		4	4	3	2		
	RA4C	60	5		45	45	35			
			10		35	35	35	30		
			20		20	20	18	15		
			30		12	12	10	8		
	RA6C	100	2.5		10	10	10			
			5		6	6	6	6		
			10		4	4	4	4	3	
			16		2	2	2	2	1	
	RA7C	200	3		20	20	20			
			6		20	15	12	12		
			12		10	8	8	6	6	
			20		4	4	3	3	2	
	RA8C	400	4		35	35	30			
			8		25	25	20	20		
			16		12	12	10	8	8	
			24		6	6	6	4	4	
RA4R	60	5	72	55	40	25				
		10		40	30	30	20			
		20		20	20	15	12	12		
		2.5		10	10	10				
RA6R	100	5		6	6	6	6			
		10		4	4	4	4			
		16		2	2	2	2			
		3		20	20	20				
RA7R	200	6		19	15	12	12			
		12		9	8	8	6			
		20		4	4	3	3			
		4		35	35	30				
RA8R	400	8		25	25	20	20			
		16		12	12	10	8			
		24		6	6	6	4			
		5	72	55	40	25				
RRA4C	60	10		40	30	30	20			
		20		20	20	15	12			
		2.5		10	10	10				
		5		6	6	6	6			
			10		4	4	4	4	3	
			16		2	2	2	2	1	

Foreword  
Slider Type  
Wide Slider Type  
Rod Type  
Radial Cylinder  
Wide Radial Cylinder  
Table Type  
Cleanroom Slider  
Cleanroom Wide Slider  
Options  
Reference Data  
Controller

# Tables of Payload by Acceleration

RCS4 vertical position

\* RCS4CR is the same.

Series	Type	Motor wattage	Lead	Payload per Acceleration/Deceleration (kg)					
				0.2G	0.3G	0.5G	0.7G	1.0G	1.2G
RCS4	RRA6C	100	3		20	20	20		
			6		20	15	12	12	
			12		10	8	8	6	6
			20		4	4	3	3	2
	RRA7C	200	4		35	35	30		
			8		25	25	20	20	
			16		12	12	10	8	8
			24		6	6	6	4	4
	RRA8C	400	5	72	50	40	25		
			10		40	30	30	20	
			20		20	20	15	12	12
			30		8	8	8	6	6
	RRA4R	60	2.5		10	10	10		
			5		6	6	6	6	
			10		4	4	4	4	4
			16		2	2	2	2	
	RRA6R	100	3		20	20	20		
			6		19	15	12	12	
			12		9	8	8	6	6
			20		4	4	3	3	
	RRA7R	200	4		35	35	30		
			8		25	25	20	20	
			16		12	12	10	8	8
			24		6	6	6	4	4
	RRA8R	400	5	72	50	40	25		
			10		34	30	30	20	
			20		17	17	15	12	12
			30		8	8	8	6	6
	WRA10C	60	2.5		10	8	8		
			5		5	5	5	5	
			10		3	3	2	2	1
	WRA12C	100	3		20	20	20		
			6		15	15	12	12	
			12		6	6	6	5	5
			20		2	2	1.5	1.5	1
	WRA14C	200	4		30	30	30		
			8		20	20	20	20	
			16		8	6	6	6	5
			24		3	3	2	2	2
	WRA16C	400	5		50	30	25		
			10		35	35	35	20	
			20		12	12	10	10	8
			30		6	5	4	3	1.5
	WRA10R	60	2.5		10	8	8		
			5		5	5	5	5	
			10		2.5	2.5	2	2	
	WRA12R	100	3		20	20	20		
			6		15	15	12	12	
12				6	6	6	5		
20				2	2	1.5	1.5		
WRA14R	200	4		30	30	30			
		8		20	20	20	20		
		16		8	6	6	6		
		24		3	3	2	2		
WRA16R	400	5		50	30	25			
		10		35	35	35	20		
		20		12	12	10	10		
		30		6	5	4	3		
WSA10C	60	2.5		10	10	6			
		5		5	5	5	5		
		10		3	3	3	3	2	
WSA12C	100	3		15	10	6			
		6		15	15	12	10		
		12		8	8	8	6	6	
		20		3	3	2	2	2	



RCS4 vertical position

\* RCS4CR is the same.

Series	Type	Motor wattage	Lead	Payload per Acceleration/Deceleration (kg)					
				0.2G	0.3G	0.5G	0.7G	1.0G	1.2G
RCS4	WSA14C	200	4		25	20	12		
			8		10	10	10	10	
			16		8	8	8	8	8
			24		2.5	2.5	2.5	2.5	2.5
	WSA16C	400	5		50	45	30		
			10		35	35	35	30	
			20		20	15	15	12	10
			30		12	12	8	8	6
	WSA10R	60	2.5		10	10	6		
			5		5	5	5	5	
			10		3	3	3	3	
	WSA12R	100	3		15	10	6		
			6		15	15	12	10	
			12		8	8	8	6	
			20		3	3	2	2	
	WSA14R	200	4		25	20	12		
			8		10	10	10	10	
			16		8	8	8	8	
			24		2.5	2.5	2.5	2.5	
	WSA16R	400	5		50	45	30		
			10		35	35	35	30	
			20		18	15	15	12	
			30		12	12	8	8	
	TA4C (Single)	60	2.5		9	9	9		
			5		6	6	6	6	
			10		3	3	3	3	3
			16		1.5	1.5	1.5	1.5	1.5
	TA4C (Double)	60	2.5		9	9	9		
			5		6	6	6	6	
			10		3	3	3	3	3
	TA6C (Single)	100	3		12	12	12		
			6		10	10	10	10	
			12		6	6	6	6	6
			20		4	4	3	3	2
	TA6C (Double)	100	3		12	12	12		
			6		10	10	10	10	
			12		6	6	6	6	6
	TA7C (Single)	200	4		20	20	20		
			8		18	18	18	18	
			16		10	10	8	8	6
24				5	5	4	4	3	
TA7C (Double)	200	4		24	24	24			
		8		18	18	18	18		
		16		8	8	8	8	6	
TA4R (Single)	60	2.5		9	9	9			
		5		6	6	6	6		
		10		3	3	3	3		
		16		1.5	1.5	1.5	1.5		
TA4R (Double)	60	2.5		9	9	9			
		5		6	6	6	6		
		10		3	3	3	3		
TA6R (Single)	100	3		10	10	8			
		6		10	10	8	8		
		12		6	6	6	6		
		20		4	4	3	3		
TA6R (Double)	100	3		12	12	12			
		6		10	10	10	10		
		12		6	6	6	6		
TA7R (Single)	200	4		20	20	20			
		8		18	18	18	18		
		16		10	10	8	8		
		24		5	5	4	4		
TA7R (Double)	200	4		24	24	24			
		8		18	18	18	18		
		16		8	8	8	8		

Foreword  
Slider Type  
Wide Slider Type  
Rod Type  
Radial Cylinder  
Wide Radial Cylinder  
Table Type  
Cleanroom Slider  
Cleanroom Wide Slider  
Options  
Reference Data  
Controller

# Selection Guideline for Allowable Load Mass

The radial cylinder has a built-in guide, so loads up to a certain level can be applied to the rod without using an external guide. Refer to the graphs below for the allowable load mass.

If the allowable load will be exceeded under the required operating conditions, add an external guide.

## Allowable Load Mass for Horizontally Mounted RCS4-RRA Series

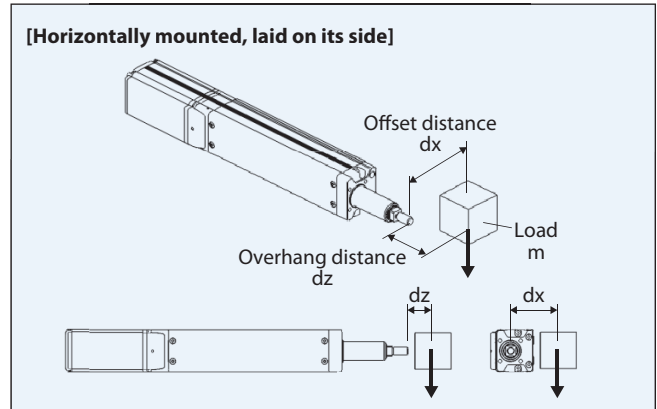
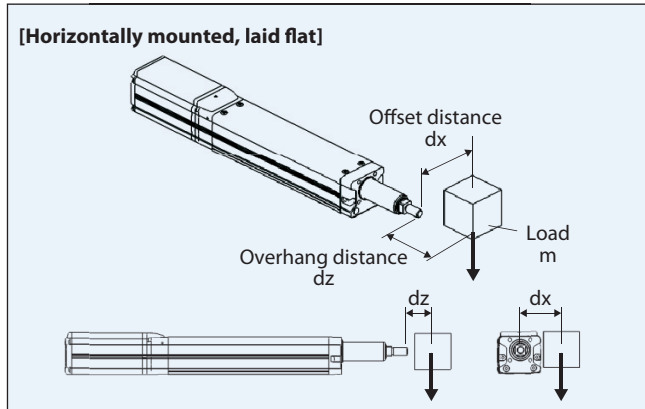

### RCS4-RRA4

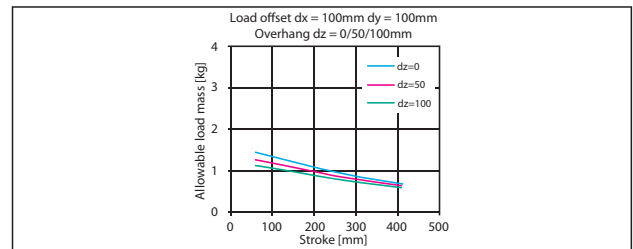
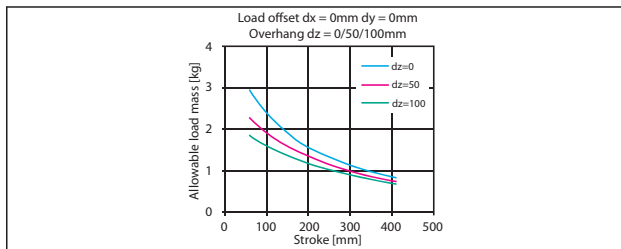

### RCS4-RRA6

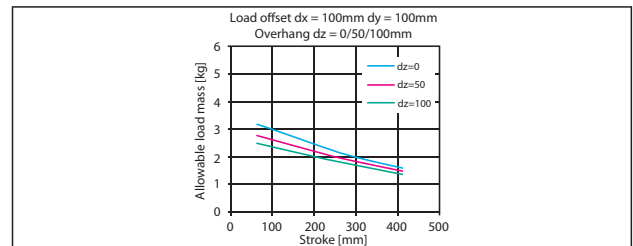
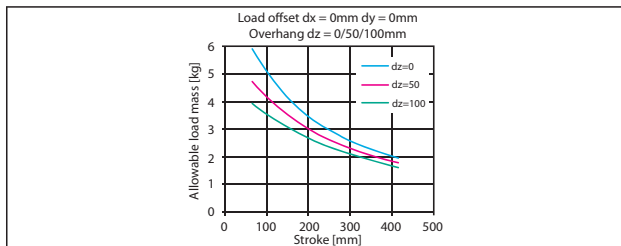

### RCS4-RRA7

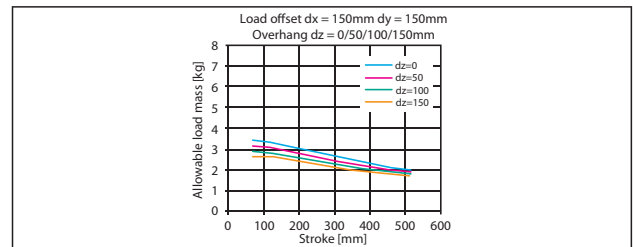
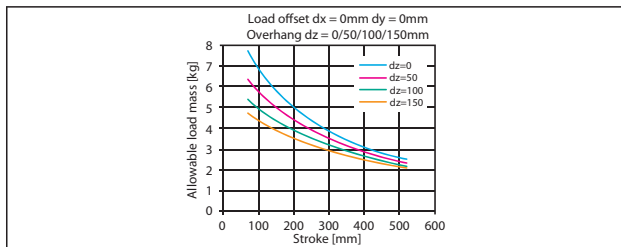

### RCS4-RRA8

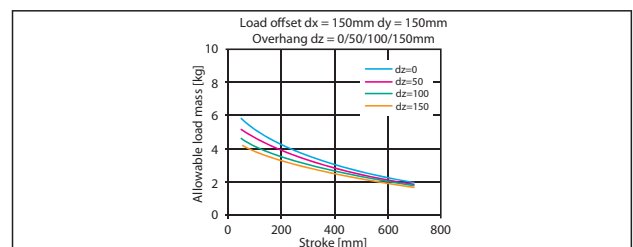
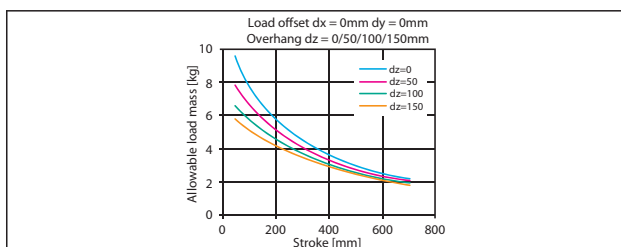

Foreword  
 Slider Type  
 Wide Slider Type  
 Rod Type  
 Radial Cylinder  
 Wide Radial Cylinder  
 Table Type  
 Cleanroom Slider  
 Cleanroom Wide Slider  
 Options  
 Reference Data  
 Controller

■ Allowable Load Mass for Vertically Mounted RCS4-RRA Series

[Vertically mounted]

Offset distance dx, Load m, dz, dx, dy, dy, dx, dy, dx

Allowable load calculation conditions.  
Load mass corresponding to a product service life of 5,000 km, considering moments generated by acceleration/deceleration.  
(Acceleration: 0.5G, speed: 500mm/s)

■ RCS4-RRA4

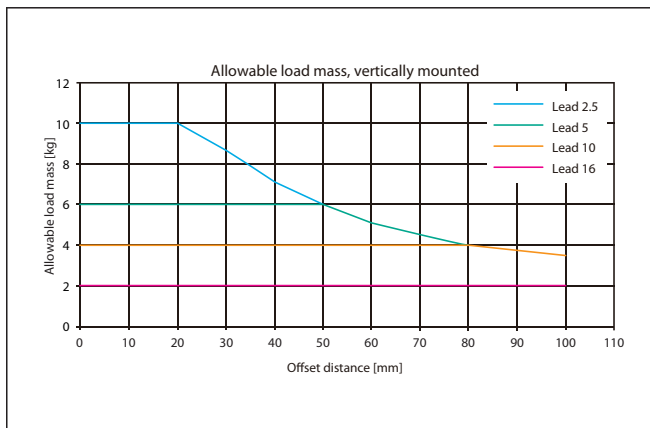

■ RCS4-RRA6

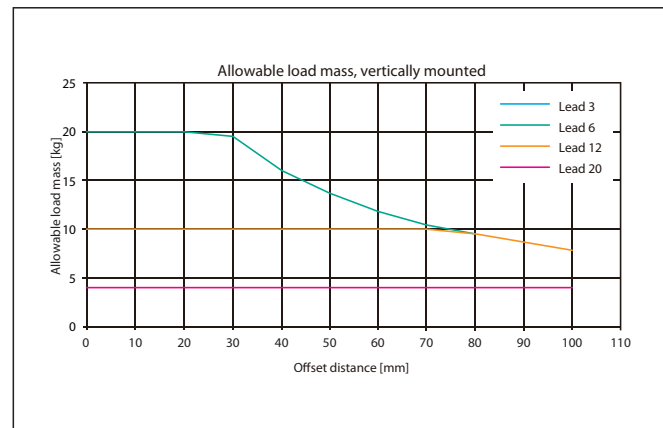

■ RCS4-RRA7

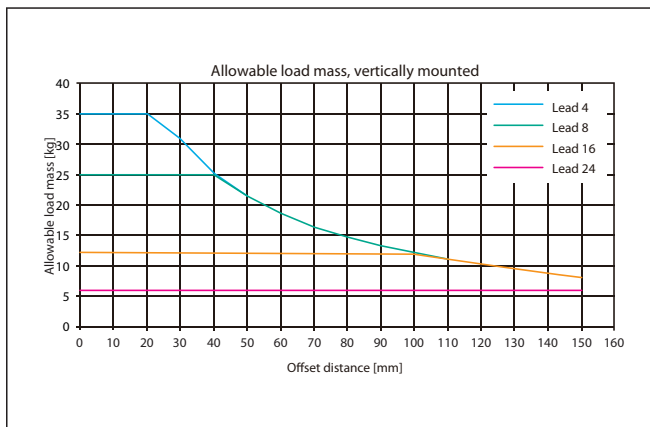

■ RCS4-RRA8

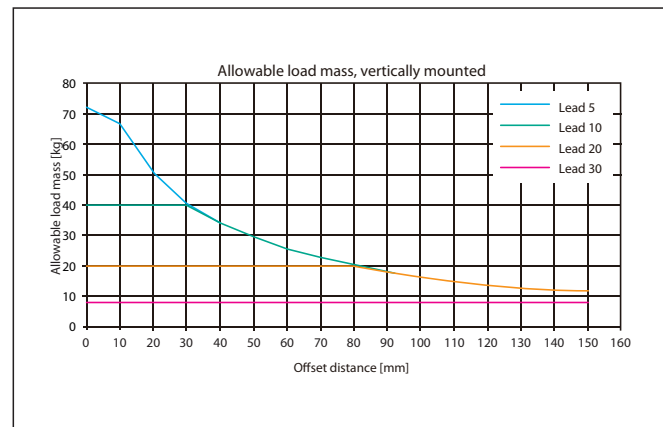

Mount Load

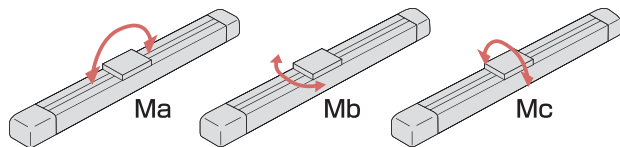

Overhang Length

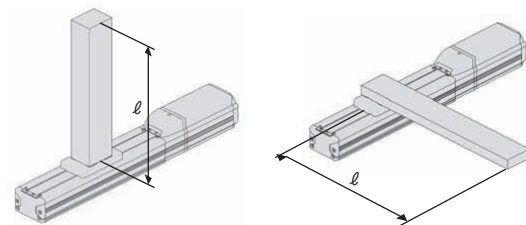

# Selection Guideline for Allowable Load Mass

## Allowable Load Mass for Horizontally Mounted RCS4-WRA Series

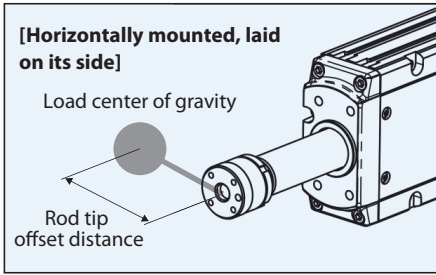
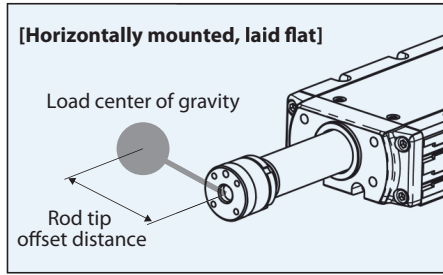

Offset = 0mm/50mm/100mm  
Overhang = 100mm or less

### RCS4-WRA10

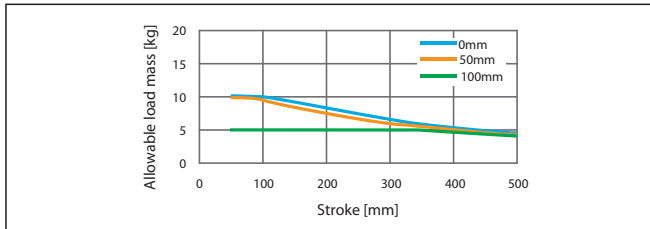

### RCS4-WRA12

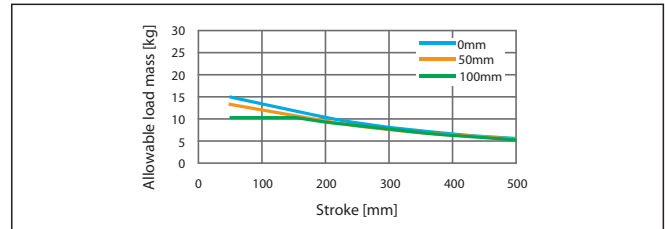

### RCS4-WRA14

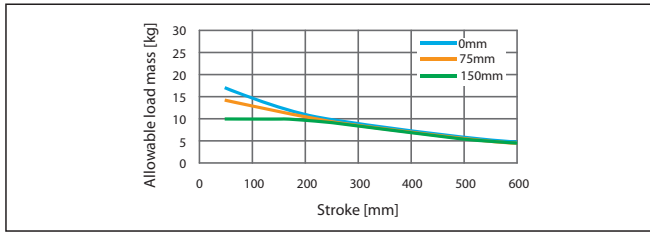

### RCS4-WRA16

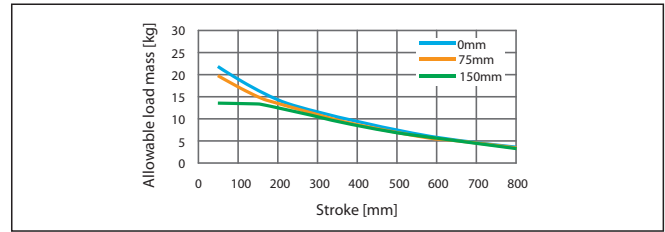

## Allowable Load Mass for Vertically Mounted RCS4-WRA Series

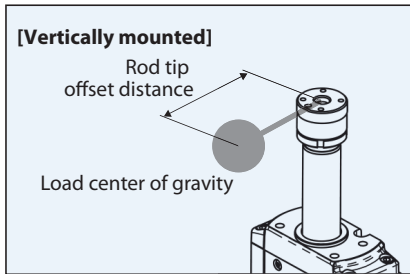

Offset = 0mm/50mm/100mm  
Overhang = 100mm or less

### RCS4-WRA10

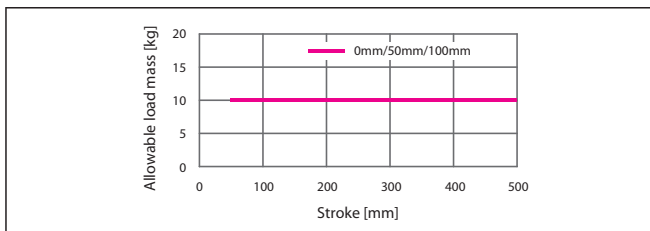

### RCS4-WRA12

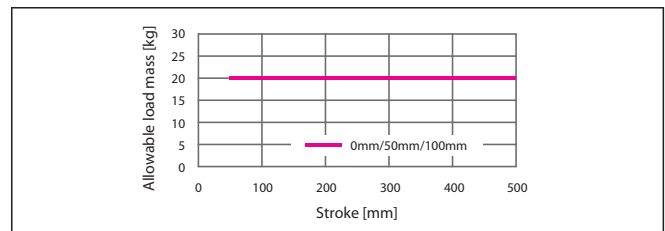

### RCS4-WRA14

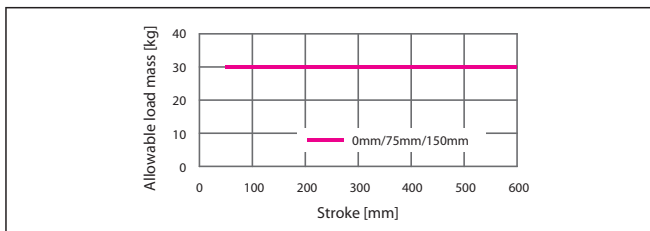

### RCS4-WRA16

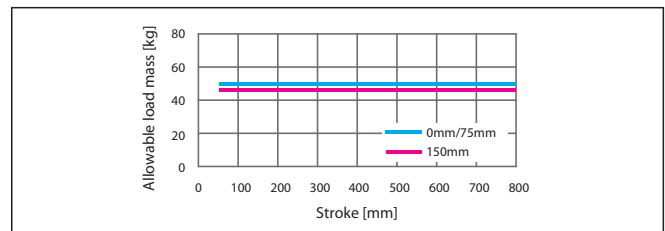

### ■ Allowable Load Mass for (Table Type) Horizontally Mounted RCS4-TA Series

Due to the table type structure, longer stroke actuators result in lower allowable load mass.

#### ■ RCS4-TA4 (horizontal)

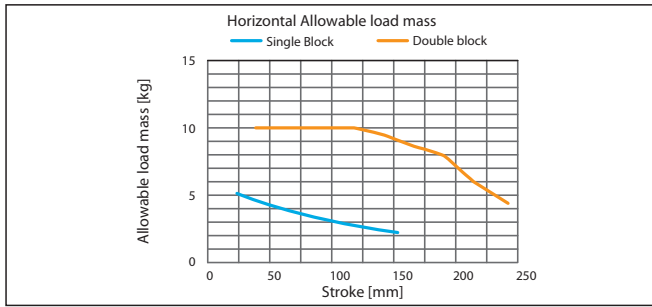

#### ■ RCS4-TA4 (side)

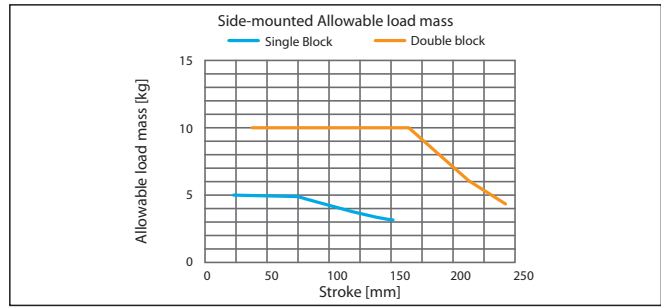

#### ■ RCS4-TA6 (horizontal)

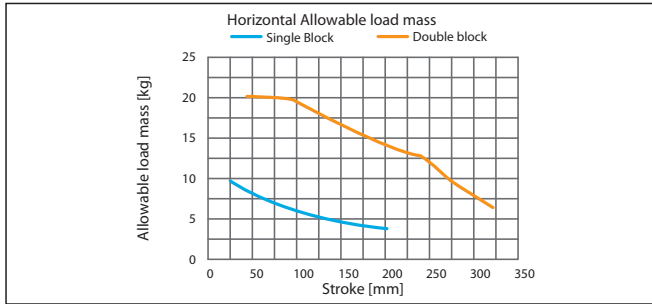

#### ■ RCS4-TA6 (side)

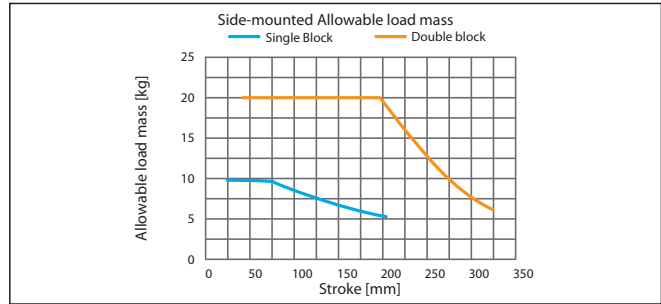

#### ■ RCS4-TA7 (horizontal)

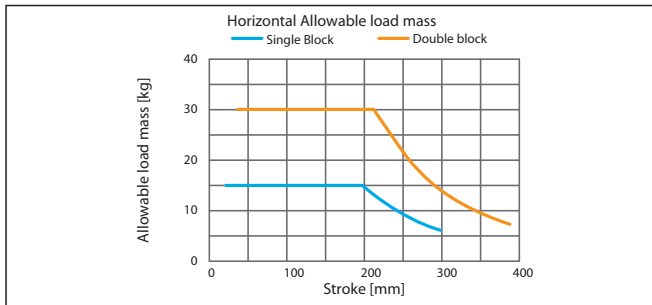

#### ■ RCS4-TA7 (side)

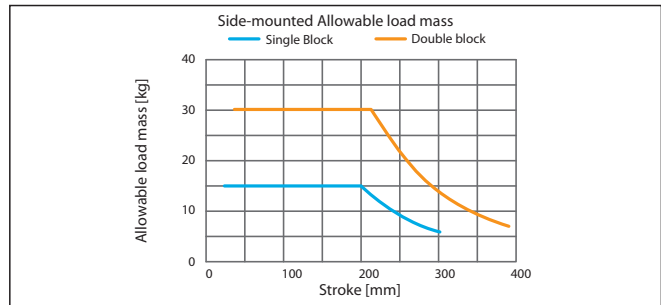

### ■ Allowable Load Mass for (Table Type) Vertically Mounted RCS4-TA Series

Due to the table type structure, longer stroke actuators result in lower allowable load mass.

#### ■ RCS4-TA4

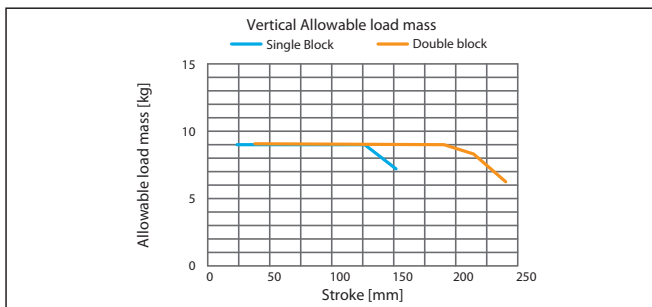

#### ■ RCS4-TA6

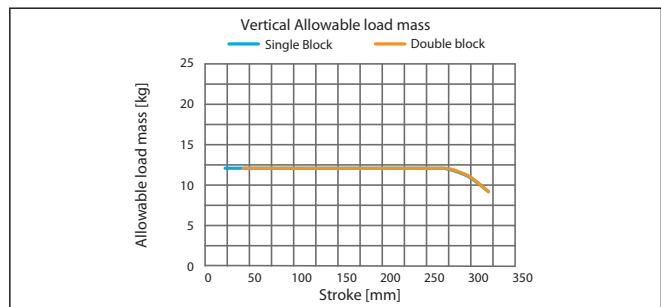

#### ■ RCS4-TA7

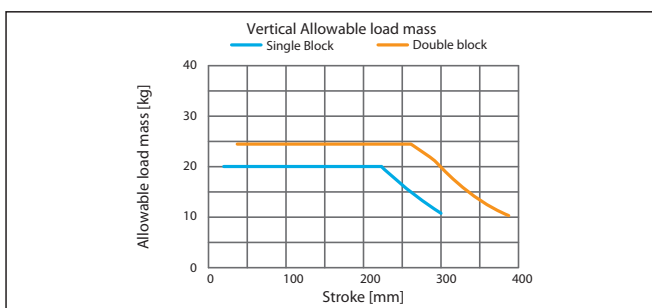

# Duty

Duty cycle varies depending on the operation conditions (payload, acceleration/deceleration, etc.).

Calculate the load factor LF and acceleration/deceleration time ratio  $t_{od}$  from the following formula and obtain it from the graph.

## ① Calculate the load factor LF from the following formula.

RCS4 can be used at or above the rated acceleration/deceleration.

The formula will differ depending on the command acceleration/deceleration.

(1) When the command acceleration/deceleration is at or below the rated acceleration/deceleration, use formula ①.

The load factor LF formula differs depending on the model. Check the target model and calculate the load factor.

$$\textcircled{A} \text{ Load factor: LF } \textcircled{1} = \frac{M \times \alpha}{M_1 \times \alpha_1} (\%)$$

- Payload at rated acceleration :  $M_1$
- Rated acceleration/deceleration :  $\alpha_1$
- Actual payload :  $M$  ( $M \leq M_1$ )
- Command acceleration/deceleration :  $\alpha$  ( $\alpha \leq \alpha_1$ )

(Note) Please refer to the model number/spec table of each model for payload and rated acceleration/deceleration at rated acceleration/deceleration.

(2) When the command acceleration/deceleration is higher than the rated acceleration/deceleration, use formula ②.

$$\textcircled{B} \text{ Load factor: LF } \textcircled{2} = \frac{M \times \alpha}{M_2 \times \alpha} = \frac{M}{M_2} (\%)$$

- Actual payload :  $M$
- Command acceleration/deceleration :  $\alpha$
- Payload of command acceleration/deceleration :  $M_2$  ( $M \leq M_2$ )

(Note) For the acceleration/deceleration of each model and the payload corresponding to that acceleration/deceleration, refer to the table of payload by acceleration for each model.

The load factor is as follows when operating under the following operating conditions.

As an example, we will use the table of payload by acceleration of "RCS4-SA8C 400 W Lead 30".

Model	Type	Motor wattage	Lead [mm]	Payload by Acceleration/Deceleration [kg]				
				0.3G	0.5G	0.7G	1G	1.2G
RCS3	SA8C	400W	30	30	25	20	15	10

(Note) When horizontally mounted, the rated acceleration/deceleration is 0.3G

### <Example 1>

Actual payload : 12kg  
 Command acceleration/deceleration : 1.0G  
 Payload of command acceleration/deceleration : 15kg  
 Load factor: LF ② = 80%

### <Example 2>

Actual payload : 12.5kg  
 Command acceleration/deceleration : 0.5G  
 Payload of command acceleration/deceleration : 25kg  
 Load factor: LF ② = 50%

### <Example 3>

Actual payload : 30kg  
 Command acceleration/deceleration : 0.3G  
 Payload of command acceleration/deceleration : 30kg  
 Load factor: LF ③ = 100%  
 (Note) Use load factor calculation method ①.

## ② Calculate the acceleration/deceleration time ratio $t_{od}$ from the following formula.

$$\text{Acceleration/deceleration time ratio: } t_{od} = \frac{\text{Acceleration time} + \text{deceleration time}}{\text{Operating time}} \%$$

$$\text{Acceleration time} = \frac{\text{Speed (mm/s)}}{\text{Acceleration (mm/s}^2\text{)}} \text{ (s)}$$

$$\text{Acceleration (mm/s}^2\text{)} = \text{Acceleration (G)} \times 9,800\text{mm/s}^2$$

$$\text{Deceleration time} = \frac{\text{Speed (mm/s)}}{\text{Deceleration (mm/s}^2\text{)}} \text{ (s)}$$

$$\text{Deceleration (mm/s}^2\text{)} = \text{Deceleration (G)} \times 9,800\text{mm/s}^2$$

## ③ Read the duty guideline from calculated "load ratio" and "acceleration/deceleration time ratio".

Duty guideline graph 1 (for standard use)

Example: When the load ratio is 80% and the acceleration/deceleration time ratio is 80%, the duty guideline will be approximately 75%.

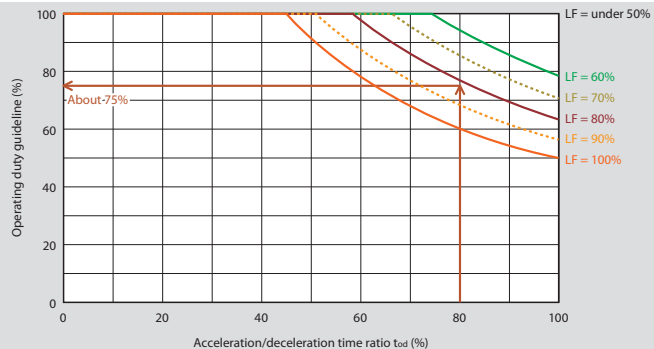

# RCS4(CR) Double Slider Specification

Series name	Type name	Lead (mm)	Allowable dynamic moment						Overhang load length (mm)	Cleanroom specification suction amount (Nℓ/min)	* Payload compensation (kg)	Slider length (mm)	Minimum stroke for double slider (mm)	
			Standard rated life (km)	Slider span (mm)		Ma direction (N·m)	Mb direction (N·m)	Mc direction (N·m)						Ma direction Mb/Mc direction
				Slider actual span	Slider cover span									
RCS4	SA4C(R)	16	5000	60	24	44.6	63.6	15.7	420	-	1	76	50	
		10												
		5												
		2.5												
	SA6C(R)	20	5000	90	40	106	152	40	630	-	2	110	50	
		12												
		6												
		3												
	SA7C(R)	24	5000	70	20	285	285	145	810	-	2	130	50	
		16												
		8												
		4												
SA8C(R)	30	5000	120	35	565	565	237	1200	-	2.5	165	50		
	20													
	10													
	5													
RCS4CR	SA4C	10	5000	60	24	44.6	63.6	15.7	420	60	1	76	50	
		5								30				
		2.5								20				
	SA6C	12	5000	90	40	106	152	40	630	110	2	110	50	
		6								60				
		3								35				
	SA7C	16	5000	70	20	285	285	145	810	100	2	130	50	
		8								50				
		4								40				
	SA8C	10	5000	120	35	565	565	237	1200	120	2.5	165	50	
		5								50				

\* Double slider specification values obtained by subtracting the payload compensation value from the standard specification payload are the payload specification values. (Note) Double slider is not configured for leads not listed in the table.

# SCON-CB



Single axis robot / Cartesian robot / Linear servo / ROBO Cylinder RCS2/RCS3/  
RCS4 position controller

## Features

### 1 Supports Battery-less Absolute Encoder

The RCS2, RCS3, RCS4, ISB and ISDB can operate equipped with a battery-less absolute encoder. As no battery is needed for retaining position data, it is possible to save control panel space, which helps to keep down the initial costs and maintenance costs.



### 2 Major field networks supported <Optional function>

Direct connection can be made to MECHATROLINK, CompoNet, EtherCAT, EtherNet/IP and PROFINET IO in addition to DeviceNet, CC-Link and PROFIBUS-DP. Operation is also possible by specifying the coordinate values directly via the field network.

DeviceNet

PROFI BUS

CompoNet

CC-Link

EtherNet/IP

EtherCAT

MECHATROLINK

PROFI NET

### 3 Equipped with vibration control function <Standard function>

The equipped vibration control function reduces the runout (vibration) of the workpiece attached to the slider of the actuator. The standby time for vibration convergence is shortened, reducing the cycle time.

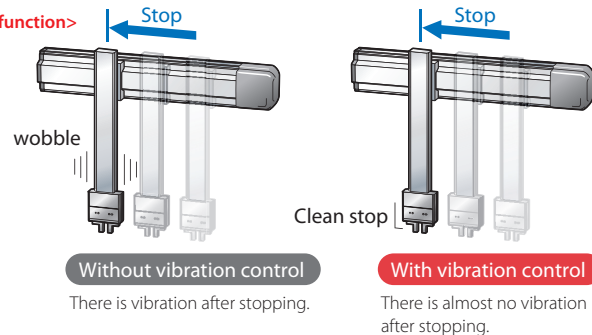

### 4 Capable of predictive maintenance <Standard function>

- A function that issues a warning when a motor overload is detected has been included  
Monitoring changes in the temperature of the motor makes it possible to detect abnormalities before the occurrence of a breakdown or a malfunction.
- Improvement of monitoring functions  
Similar to an oscilloscope, it is now possible to acquire the waveforms of the position, speed, etc. from the instant the state of the selected signal changes. Also, it is possible to acquire the signal states of positioning complete, alarms, etc.
- Smart tuning and off-board tuning enable acceleration/deceleration and gain adjustment according to the payload.
- A function that integrates the number of cycles with the traveled distance accumulation makes it possible to check maintenance timing.
- The calendar function makes it possible to keep a timetable of the alarms that have been generated.

<Maintenance information>

Total moving count	123 <<	< Send
Total moving count threshold	0	
Total moving distance[m]	456 <<	< Send
Total moving distance threshold[m]	0	

<Calendar function>

Data type	Code	Message	Addr	Detail	Time (H/M/S)	Time (h:m:s)
Decomposed Item	FFF	PowerOP No. Error	----	----	22/11/14	21:57:58
History 1	0CE	Control power voltage reduction	----	----	01/11/09	04:54:49
History 2	FFF	PowerOP No. Error	----	----	01/11/08	04:44:48
History 3	0CE	Control power voltage reduction	----	----	01/11/09	09:43:07
History 4	FFF	PowerOP No. Error	----	----	01/11/09	09:30:41
History 5	0CE	Control power voltage reduction	----	----	01/11/09	10:15:38
History 6	0CE	Control power voltage reduction	----	----	01/11/09	10:04:59
History 7	FFF	PowerOP No. Error	----	----	01/11/09	10:04:46
History 8						
History 9						
History 10						
History 11						
History 12						
History 13						
History 14						
History 15						



Model Number		SCON-CB									
External view											
I/O type		Standard specification		Field network type (*1)							
		PIO connection specification (*1)		DeviceNet connection specification CC-Link connection specification PROFIBUS-DP connection specification CompoNet connection specification MECHATROLINK-I/II connection specification MECHATROLINK-III connection specification EtherCAT connection specification EtherNet/IP connection specification PROFINET IO connection specification							
I/O type model number		NP/PN	DV	CC	PR	CN	ML	ML3	EC	EP	PRT
Supported encoder		Battery-less Absolute Incremental Quasi absolute	Absolute	Battery-less absolute/Incremental/Absolute/Quasi absolute							
SCON-CB	12~150W	-	-								
	200W	-	-								
	300~400W	-	-	-	-	-	-	-	-	-	-
	600W	-	-								
	750W	-	-								

(\*1) Please note that the network specifications cannot use PIO or pulse train communication.  
 (Note) The index absolute type cannot be used in the pulse-train control and MECHATROLINK III control. (Please contact IAI America for more information)  
 (Reference) Please contact IAI America for details of the PLC function equipped type.

Model

**SCON** - [ ] - [ ] [ ] [ ] - [ ] - [ ] - [ ]

Series      Type      Motor Type      Encoder Type      Options      I/O Type      I/O Cable Length      Input power

CB	High-function type			HA	Hi-accel./decel. specification		1	Single phase 100VAC
CGB	Safety category type						2	Single phase 200VAC

\* High acceleration/deceleration specification is only available if the high acceleration/deceleration supported option is selected for the actuator.  
 <High Acceleration/Deceleration Target Actuators>  
 RCS2-SA4C/SA5C/SA6C/ SA7C/RA4C/RA5C/RGS4C/ RGS5C/RGD4C/RGD5C

\* Check the power supply voltage that can be selected in the actuator page.

12	12W	150	150W
20	20W	200	200W
30D	30W	200S	200W
30R	30W	300S	300W
60	60W	400	400W
100	100W	600	600W
100S	100W	750	750W

WAI	Battery-less Absolute Incremental
A	Absolute
G	Quasi absolute *1
AI	Index absolute type *2
AM	Absolute Multi-rotation type *2

\*1 The quasi absolute is for LSAS Series.  
 \*2 DD motor operation mode is added.

NP	PIO NPN spec. (Standard)
PN	PIO PNP spec.
DV	DeviceNet connection specification
CN	CompoNet connection specification
CC	CC-Link connection specification
ML	MECHATROLINK-I, II connection specification (Note 1)
ML3	MECHATROLINK-III connection specification (Note 1)
PR	PROFIBUS-DP connection specification
EC	EtherCAT connection specification
EP	EtherNet/IP connection specification
PRT	PROFINET IO connection specification

0	No cable
2	2m(Standard)
3	3m
5	5m

\* When a field network specification is selected, the I/O cable length is "0" (No cable).

(Example) 12:12W servo motor supported

**Notes**

In principle, the same type of motor as the type of motor of the actuator to be connected should be entered, but there are some models where the motor type of some controllers and actuators do not match. Be sure to check the corresponding models listed below during selection.

<30D/30R/200S Target Actuators>

- Controller motor type [30D] 30W actuators other than RS
- Controller motor type [30R] RS
- Controller motor type [200S] DD-LT18□ DDCR-LT18□ DDA-LT18C DDACR-LT18C

\* For 200S, the controller casing will be 400W. Check the 400W specification for the price.

(Note 1) For precautions during selection, be sure to contact IAI America for more details.

Foreword  
 Slider Type  
 Wide Slider Type  
 Rod Type  
 Radial Cylinder  
 Wide Radial Cylinder  
 Table Type  
 Cleanroom Slider  
 Cleanroom Wide Slider  
 Options  
 Reference Data  
 Controller

## <SCON-CB/CGB>

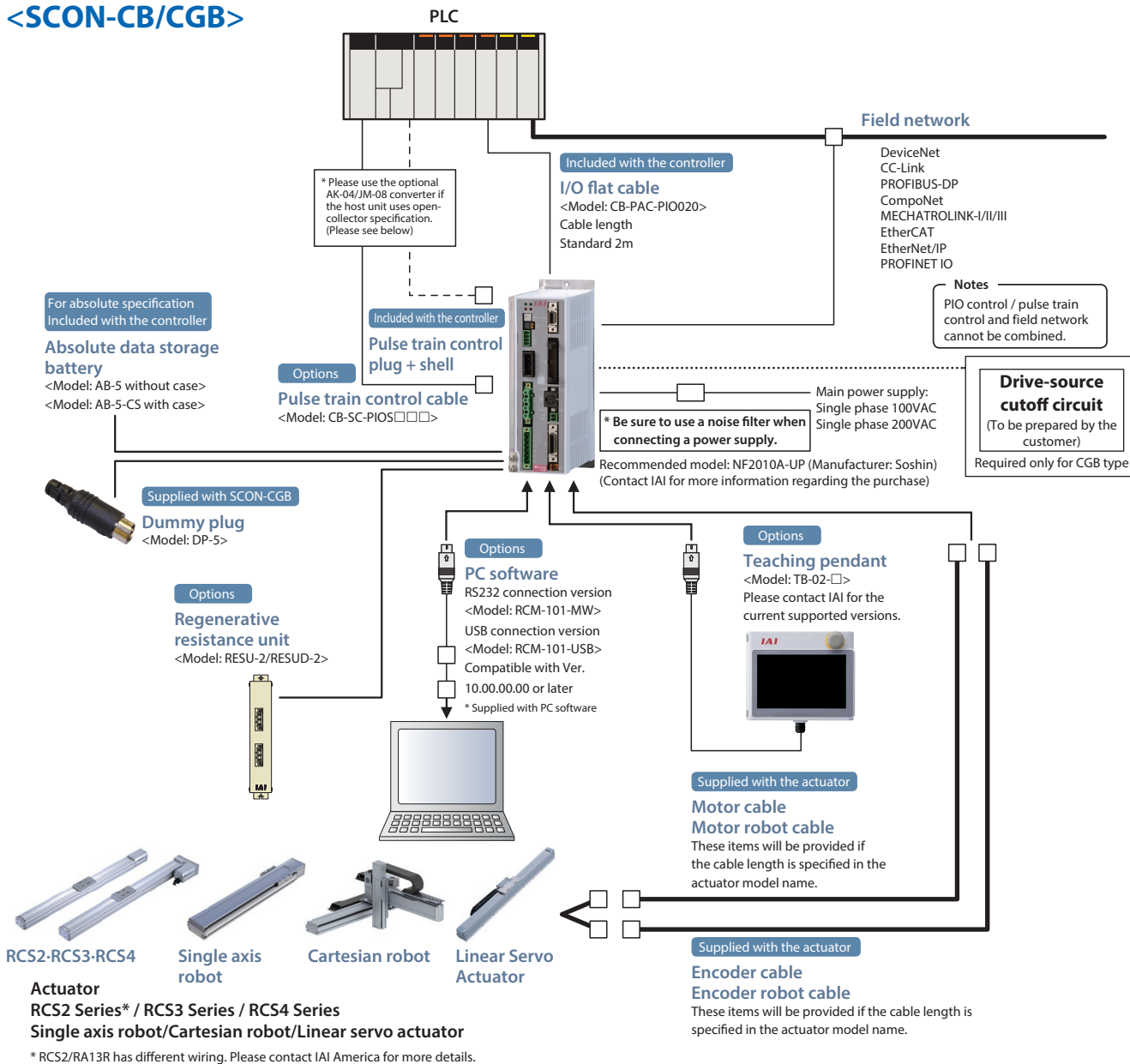

### ■ Pulse Converter: Model AK-04

Converts open-collector specification pulses to the differential system. Please use this converter if the host controller uses open-collector specification for output pulse.

#### ■ Specifications

Item	Specification
Input power	24VDC ±10% (Max. 50mA)
Input pulse	Open collector (collector current max. 12mA)
Input frequency	200kHz or less
Output pulse	Differential output (Max. 10mA) (26C31 or equivalent)
Mass	10g or less (not including the cable connectors)
Accessories	37104-3122-000L (e-CON connector) x 2 by 3M Suitable power line AWG No.24~26

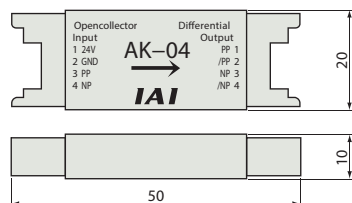

### ■ Pulse Converter: Model JM-08

Converts differential pulses to the open-collector specification. Please use this converter if the host controller uses open-collector specification for pulse input.

#### ■ Specifications

Item	Specification
Input power	24VDC ±10% (Max. 50mA)
Input pulse	Differential input (Max. 10mA) (RS422 compliant)
Input frequency	500kHz or less
Output pulse	24VDC open collector (collector current max. 25mA)
Mass	10g or less (not including the cable connectors)
Accessories	37104-3122-000FL (e-CON connector) x 2 by 3M Suitable power line AWG No.24~26

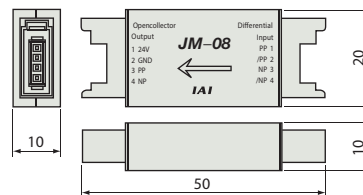

The control method of this controller can be selected from positioner mode and pulse train control mode.

In positioner mode, it can be operated by specifying the position data (travel position, speed, acceleration, etc.) numbers input to the controller from the outside using I/O (input/output signal).

As well, in positioner mode, 8 different operation modes can be selected depending on the parameters.

In pulse train control mode, it is possible to control the travel distance, speed, acceleration and the like with pulses sent from an external pulse generator.

Mode		Type	Number of positioning points	Features
Positioner mode	Positioning mode	PIO pattern 0	64 points	This is the factory default standard mode. Specify from outside the position number you want to move.
	Teaching mode	PIO pattern 1	64 points	In this mode, the slider (rod) can be moved with an external signal to register the stop position as position data.
	256-point mode	PIO pattern 2	256 points	In this mode, the number of positioning points in positioning mode is increased to 256.
	512-point mode	PIO pattern 3	512 points	In this mode, the number of positioning points in positioning mode is increased to 512.
	Solenoid valve mode 1	PIO pattern 4	7 points	This mode allows travel by signal ON/OFF alone, as with air cylinder solenoid valves.
	Solenoid valve mode 2	PIO pattern 5	3 points	In solenoid valve mode, the output signal is the same as the air cylinder auto switch.
	Force control mode 1	PIO pattern 6	32 points	In this mode, position movement during force control can be done with positioning mode. (The maximum number of positioning points is 32)
	Force control mode 2	PIO pattern 7	5 points	In this mode, position movement during force control can be done with solenoid valve mode. (The maximum number of positioning points is 5)
Pulse train control mode	Pulse train control mode for incremental	PIO pattern 0	—	Position data input to the controller is not required, as operation is according to the transmitted pulses.
	Pulse train control mode for absolute	PIO pattern 1		

Table of I/O Signals \* I/O signal assignment can be selected from 9 types.

Pin No.	Category	Number of positioning points	Parameter (PIO pattern) selection									Pulse train mode
			0	1	2	3	4	5	6	7	0/1	
			Positioning mode 64 points	Teaching mode 64 points	256-point mode 256 points	512-point mode 512 points	Solenoid valve mode 1 7 points	Solenoid valve mode 2 3 points	Force control mode 1 32 points	Force control mode 2 5 points	—	
1A	24V		P24									P24
2A	24V		P24									P24
3A	—		NC									NC
4A	—		NC									NC
5A	Input	IN0	PC1	PC1	PC1	PC1	ST0	ST0	PC1	ST0	SON	
6A		IN1	PC2	PC2	PC2	PC2	ST1	ST1(JOG+)	PC2	ST1	RES	
7A		IN2	PC4	PC4	PC4	PC4	ST2	ST2(-)	PC4	ST2	HOME	
8A		IN3	PC8	PC8	PC8	PC8	ST3	—	PC8	ST3	TL	
9A		IN4	PC16	PC16	PC16	PC16	ST4	—	PC16	ST4	CSTP	
10A		IN5	PC32	PC32	PC32	PC32	ST5	—	—	—	DCLR	
11A		IN6	—	MODE	PC64	PC64	ST6	—	—	—	BKRL	
12A		IN7	—	JISL	PC128	PC128	—	—	—	—	RMOD	
13A		IN8	—	JOG+	—	PC256	—	—	—	CLBR	CLBR	RSTR Note 1
14A		IN9	BKRL	JOG-	BKRL	BKRL	BKRL	BKRL	BKRL	BKRL	BKRL	—
15A		IN10	RMOD	RMOD	RMOD	RMOD	RMOD	RMOD	RMOD	RMOD	RMOD	—
16A		IN11	HOME	HOME	HOME	HOME	HOME	—	HOME	HOME	—	
17A		IN12	*STP	*STP	*STP	*STP	*STP	—	*STP	*STP	—	
18A		IN13	CSTR	CSTR/PWRT	CSTR	CSTR	—	—	CSTR	—	—	
19A		IN14	RES	RES	RES	RES	RES	RES	RES	RES	—	
20A	IN15	SON	SON	SON	SON	SON	SON	SON	SON	—		
1B	Output	OUT0	PM1	PM1	PM1	PM1	PE0	LSO	PM1	PE0	PWR	
2B		OUT1	PM2	PM2	PM2	PM2	PE1	LS1(TRQS)	PM2	PE1	SV	
3B		OUT2	PM4	PM4	PM4	PM4	PE2	LS2(-)	PM4	PE2	INP	
4B		OUT3	PM8	PM8	PM8	PM8	PE3	—	PM8	PE3	HEND	
5B		OUT4	PM16	PM16	PM16	PM16	PE4	—	PM16	PE4	TLR	
6B		OUT5	PM32	PM32	PM32	PM32	PE5	—	TRQS	TRQS	*ALM	
7B		OUT6	MOVE	MOVE	PM64	PM64	PE6	—	LOAD	LOAD	*EMGS	
8B		OUT7	ZONE1	MODES	PM128	PM128	ZONE1	ZONE1	CEND	CEND	RMDS	
9B		OUT8	PZONE/ZONE2	PZONE/ZONE1	PZONE/ZONE1	PM256	PZONE/ZONE2	PZONE/ZONE2	PZONE/ZONE1	PZONE/ZONE1	ALM1	
10B		OUT9	RMDS	RMDS	RMDS	RMDS	RMDS	RMDS	RMDS	RMDS	ALM2	
11B		OUT10	HEND	HEND	HEND	HEND	HEND	HEND	HEND	HEND	ALM4	
12B		OUT11	PEND	PEND/WEND	PEND	PEND	PEND	—	PEND	PEND	ALM8	
13B		OUT12	SV	SV	SV	SV	SV	SV	SV	SV	*OVLW/*ALML	
14B		OUT13	*EMGS	*EMGS	*EMGS	*EMGS	*EMGS	*EMGS	*EMGS	*EMGS	REND Note 1	
15B		OUT14	*ALM	*ALM	*ALM	*ALM	*ALM	*ALM	*ALM	*ALM	ZONE1	
16B	OUT15	*BALM	*BALM	*BALM	*BALM	*BALM	*BALM	*BALM	*BALM	ZONE2		
17B	—									—		
18B	—									—		
19B	0V					N				N		
20B	0V					N				N		

\* Parentheses in the above symbol names show functions before home return.

\* The above signal names marked with \* are set to OFF when the actuator is operating.

Note 1: Used only with pulse train control mode PIO pattern 1

Foreword  
Slider Type  
Wide Slider Type  
Rod Type  
Radial Cylinder  
Wide Radial Cylinder  
Table Type  
Cleanroom Slider  
Cleanroom Wide Slider  
Options  
Reference Data  
Controller

If the SCON-CB is controlled via a field network, you can select one of the following nine modes to operate the actuator. Please note that the data areas required on the PLC side will vary depending on the mode.

■ Mode Description

	Mode	Description
0	Remote I/O mode	Similarly to the PIO specification, this mode operates by directing bytes to ON/OFF via a network. The number of positioning points and functions will vary depending on the operation patterns (PIO patterns) set by the controller's parameters.
1	Position/simple direct value mode	The target position value is directly input, while all other operational conditions (speed, acceleration, etc.) are set by indicating the position number corresponding to the desired operating conditions from the position data table.
2	Half direct value mode	The actuator is operated by directly inputting values for speed, acceleration/deceleration rate and push current, as well as the target position.
3	Full direct value mode	The actuator is operated by directly inputting values for the target position, speed, acceleration/deceleration rate and push current limit value, etc. In addition, you are able to read the current position, current speed, and the command current value, etc.
4	Remote I/O mode 2	This mode is the same as the remote I/O mode above, with the added functionality of reading current position and the command current value.
5	Position/simple direct value mode 2	This mode is equipped with a force control function instead of the teaching and zone functions of the position/simple direct value mode above.
6	Half direct value mode 2	Instead of the half direct value mode command current reading function, it can read load cell data. It also supports the force control function.
7	Remote I/O mode 3	This mode is the same as the remote I/O mode above, with the added functionality of reading current position and load cell data.
8	Half direct value mode 3	This mode supports the vibration control function instead of the jog function of the half direct 2 value mode.

■ Required Data Size for Each Network

	Mode	DeviceNet	CompoNet	CC-Link	MECHATROLINK-I, II	PROFIBUS-DP	EtherCAT	EtherNet/IP	PROFINET IO
0	Remote I/O mode	2 bytes	2 bytes	1 station	2 bytes	2 bytes	2 bytes	2 bytes	2 bytes
1	Position/simple direct value mode	8 bytes	8 bytes	1 station	8 bytes	8 bytes	8 bytes	8 bytes	8 bytes
2	Half direct value mode	16 bytes	16 bytes	2 stations	16 bytes	16 bytes	16 bytes	16 bytes	16 bytes
3	Full direct value mode	32 bytes	32 bytes	4 stations	× (Note 1)	32 bytes	32 bytes	32 bytes	32 bytes
4	Remote I/O mode 2	12 bytes	12 bytes	1 station	12 bytes	12 bytes	12 bytes	12 bytes	12 bytes
5	Position/simple direct value mode 2	8 bytes	8 bytes	1 station	8 bytes	8 bytes	8 bytes	8 bytes	8 bytes
6	Half direct value mode 2	16 bytes	16 bytes	2 stations	16 bytes	16 bytes	16 bytes	16 bytes	16 bytes
7	Remote I/O mode 3	12 bytes	12 bytes	1 station	12 bytes	12 bytes	12 bytes	12 bytes	12 bytes
8	Half direct value mode 3	16 bytes	16 bytes	2 stations	16 bytes	16 bytes	16 bytes	16 bytes	16 bytes

(Note 1) Please note that the MECHATROLINK specification does not support the full direct value mode.

■ List of Functions by Operation Mode

	Remote I/O mode	Position/simple direct value mode	Half direct value mode	Full direct value mode (Note 1)	Remote I/O mode 2	Position/simple direct value mode 2	Half direct value mode 2	Remote I/O mode 3	Half direct value mode 3
Number of positioning points	512 points	768 points	Unlimited	Unlimited	512 points	768 points	Unlimited	512 points	Unlimited
Operates by direct assignment of position data	×	○	○	○	×	○	○	×	○
Direct assignment of speed/acceleration	×	×	○	○	×	×	○	×	○
Push-motion operation	○	○	○	○	○	○	○	○	○
Current position read	×	○	○	○	○	○	○	○	○
Current speed read	×	×	○	○	×	×	○	×	○
Operation by position number input	○	○	×	×	○	○	×	○	×
Completed position number read	○	○	×	×	○	○	×	○	×
Force control	△ (Note 2)	×	×	○	△ (Note 2)	○	○	△ (Note 2)	×
Vibration control	○	○	×	○	○	○	×	○	○
Servo gain switching	○	○	○	○	○	○	×	○	○

\* ○ indicates that the operation is supported, and X indicates that it is not supported.

(Note 1) Please note that the MECHATROLINK specification does not support the full direct value mode.

(Note 2) Usable when PIO pattern is set to 6 or 7.

### Positioning Mode / Teaching Mode / Solenoid Valve Mode

PIO connector (NPN specification)

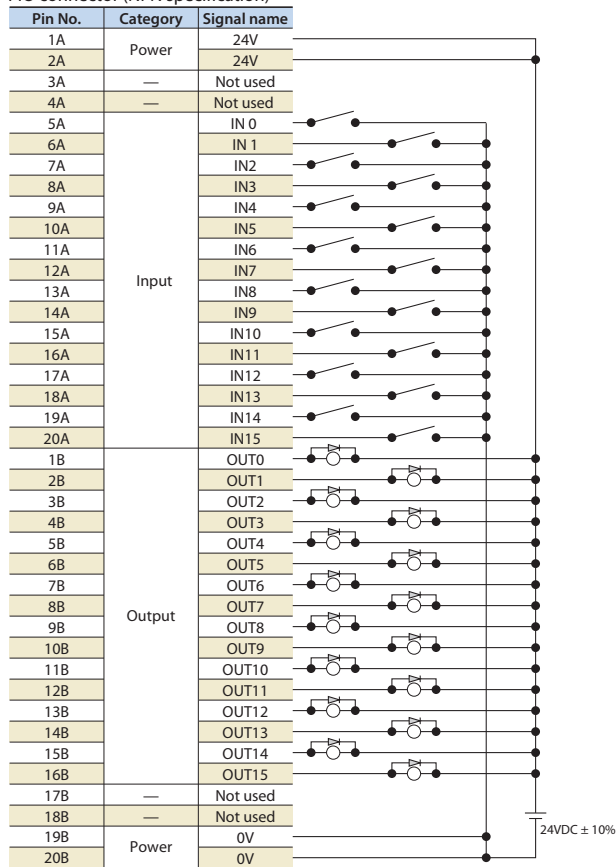

\* Connect pin numbers 1A and 2A to 24V, and connect pin numbers 19B and 20B to 0V.

### Pulse Train Mode (Differential output)

Pulse connector

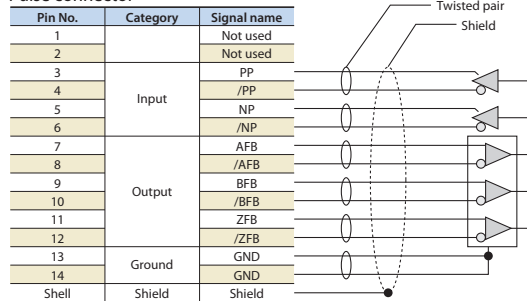

PIO connector (NPN specification)

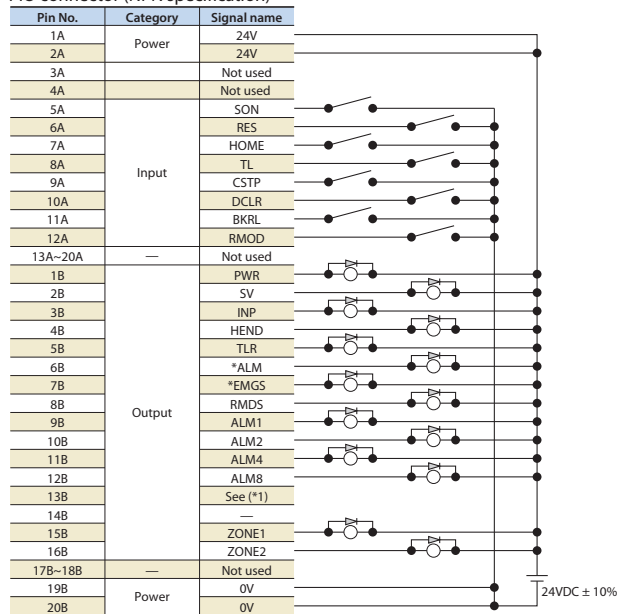

\* The shield of the twisted pair cable connected to the pulse connector must be connected to the shell. Also, set the cable length within 10m.

\* Connect pin numbers 1A and 2A to 24V, and connect pin numbers 19B and 20B to 0V.  
(\*1) -\*/ALML\*/OVLW\*/BALM (can be switched by parameter)

### PIO Input/Output Interface

#### Input External input specification

Item	Specification
Input voltage	24VDC ±10%
Input current	4mA/circuit
ON/OFF voltage	ON voltage: Min. 18.0VDC OFF voltage Max. 6.0VDC
Isolation method	Photocoupler

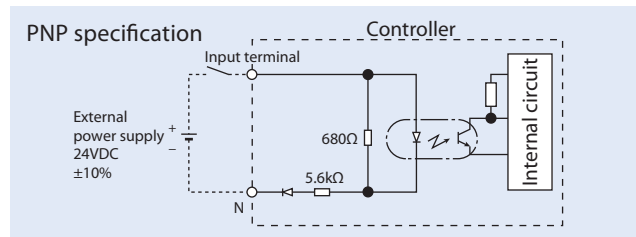
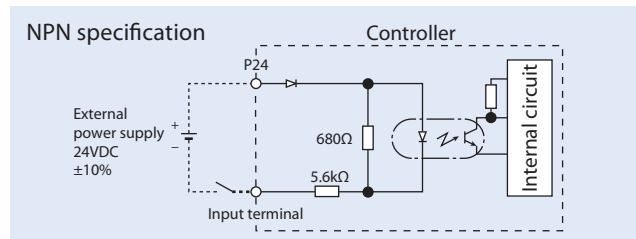

#### Output External output specification

Item	Specification
Load voltage	24VDC
Maximum load current	50mA/point
Leakage current	Max. 0.1mA/point
Isolation method	Photocoupler

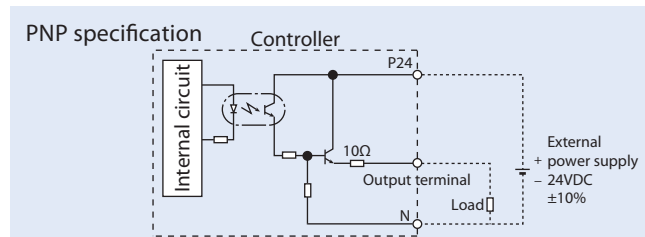
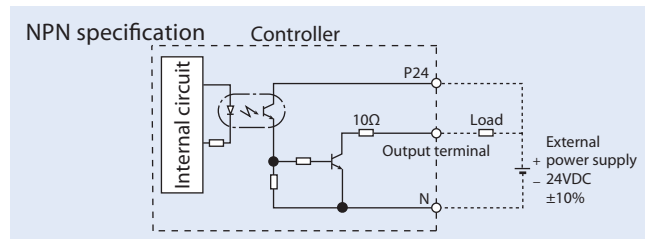

Foreword  
Slider Type  
Wide Slider Type  
Rod Type  
Radial Cylinder  
Wide Radial Cylinder  
Table Type  
Cleanroom Slider  
Cleanroom Wide Slider  
Options  
Reference Data  
Controller

## Pulse Train Type Input/Output Specification (differential line driver specification)

### Input part

**Maximum input pulse** : Line driver interface 2.5Mpps  
**Isolation method** : Photocoupler isolation

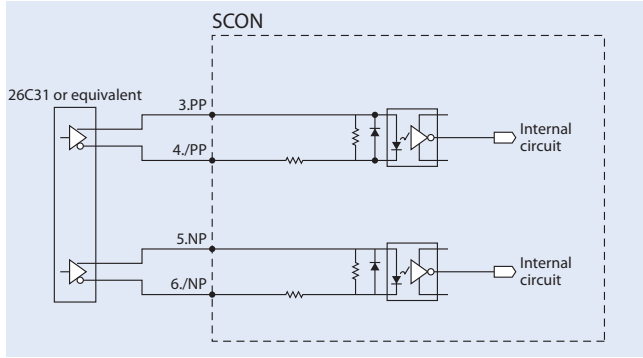

### Output part

**Maximum output pulse** : Line driver interface 2.5Mpps  
**Isolated/Non-isolated** : Non-isolated

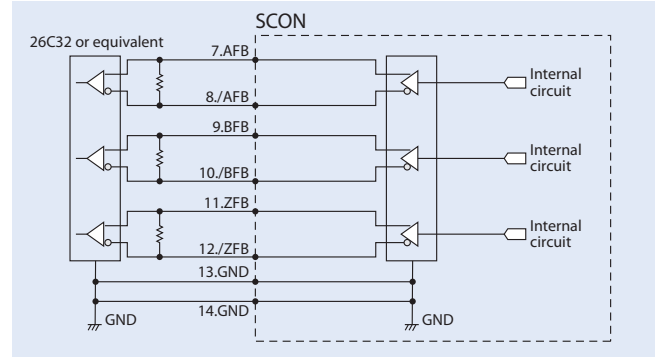

## Pulse Train Type Input/Output Specification (open collector specification)

The AK-04 (optional) is needed to input pulses. The JM-08 (optional) is required for pulse train output.

**Maximum input pulse** : 200kpps (AK-04 required)  
**Maximum output pulse** : 500kpps (JM-08 required)

- \* The 24VDC power supply connected to the AK-04 should be common with the PIO interface power supply.
- \* Make sure that the cable between the pulse output unit (PLC) and AK-04/JM-08 is as short as possible. Also, make sure that the cable length between AK-04/JM-08 and the pulse connector is within 2m.

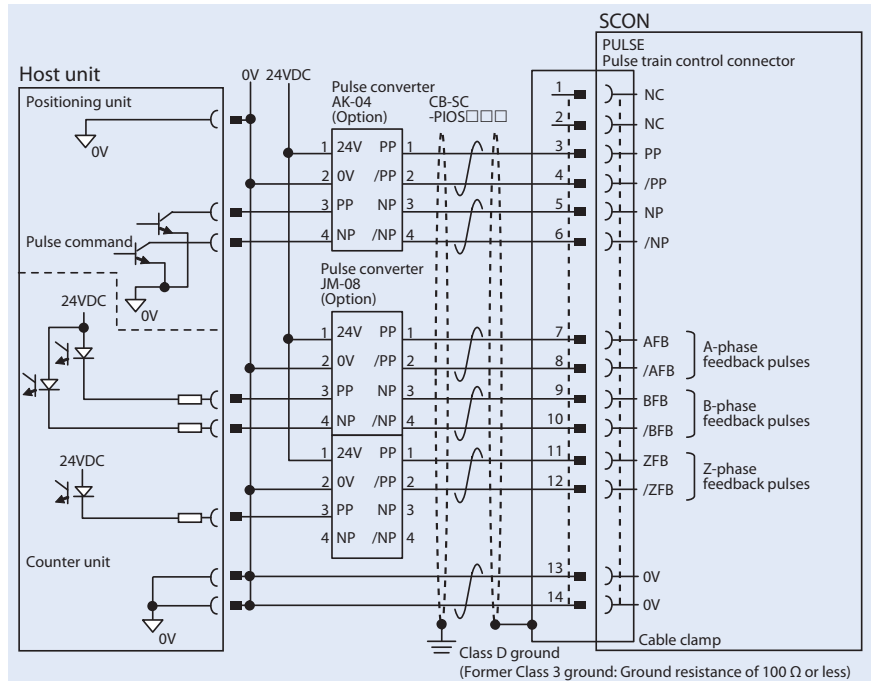

### Notes

Use the same power supply for open collector input/output to/from the host and for the AK-04 and JM-08.

## Command Pulse Input Patterns

Command pulse train pattern		Input terminal	Forward	Reverse	
Negative logic	Forward pulse train	PP./PP			
	Reverse pulse train	NP./NP			
	A forward pulse train indicates the amount of motor rotation in the forward direction, while a reverse pulse train indicates the amount of motor rotation in the reverse direction.				
	Pulse train	PP./PP			
	Sign	NP./NP	Low	High	
The command pulses indicate the amount of motor rotation, while the sign indicates the rotating direction.					
Positive logic	Forward pulse train	PP./PP			
	Reverse pulse train	NP./NP			
	Command phases A and B pulse having a 90° phase difference (multiplier is 4) indicate the amount of motor rotation and the rotating direction.				
	Pulse train	PP./PP			
	Sign	NP./NP	High	Low	
Phase A/B pulse train	PP./PP				
	NP./NP				

Item	Specification	
Compatible motor capacity	Less than 400W	400W or more
Number of controlled axes	1-axis	
Method of operation	Positioner type/Pulse train type	
Number of positioning points	512 points (PIO specification), 768 points (fieldbus specification)	
Backup memory	Non-volatile memory (FRAM)	
I/O connector	40-pin connector	
Number of I/O points	Input 16 points / output 16 points	
I/O power supply	External supply 24VDC ±10%	
Serial communication	RS485 1ch	
Command pulse train input method (Note 1)	Differential line driver output supported	
Maximum input pulse frequency	Differential line driver system: Max. 2.5Mpps / Open collector system (pulse converter used): Max. 200kpps	
Position detection method	Incremental encoder / absolute encoder / serial encoder quasi absolute / battery-less absolute encoder	
Drive-source cutoff function	CB: available (relay built in) CGB: not available	
Electromagnetic brake forced release	External brake release switch ON/OFF	
Input power	Single phase 100~115VAC ±10% Single phase 200~230VAC ±10%	Single phase 200~230VAC ±10%
Power supply capacity (Note 2)	12W / 89VA 20W / 74VA 30W (Excluding RS)/94VA 30W (For RS)/186VA 60W (Excluding RCS3-CTZ5C)/186VA 60W (For RCS3-CTZ5C)/245VA 100W / 282VA 150W / 376VA 200W / 469VA	100SW (For LSA/LSAS-N10) <sup>(*)</sup> /331VA 200SW (For LSA-S10H, LSA/LSAS-N15S) <sup>(*)</sup> /534VA 200SW (For LSA/LSAS-N15H) <sup>(*)</sup> /821VA 300W (For LSA-N19) <sup>(*)</sup> /710VA 400W (Excluding RCS3-CT8C)/968VA 400W (For RCS3-CT8C)/1278VA 600W / 1212VA 750W / 1569VA
Vibration resistant	X, Y, and Z directions 10~57Hz Single-side width 0.035mm (continuous), 0.075mm (intermittent) 58~150Hz 4.9m/s <sup>2</sup> (continuous), 9.8m/s <sup>2</sup> (intermittent)	
Calendar/clock functionality	Retention time	Approx. 10 days
	Charging time	Approx. 100 hours
Protection functionality	Overcurrent, abnormal temperature, fan speed degradation monitoring, encoder disconnection, etc.	
Ambient operating temperature	0 to 40°C	
Ambient operating humidity	85% or less (Non-condensing)	
Operating ambience	Free from corrosive gases	
Ingress protection	IP20	
Mass	Approx. 900g (25g added for simple absolute specification)	Approx. 1.2kg (25g added for simple absolute specification)
External dimensions	58mm(W)×194mm(H)×121mm(D)	72mm(W)×194mm(H)×121mm(D)

(Note 1) Use a differential line driver method resistant to noise for the command pulse input method.  
If the open collector method must be used, convert the pulse to differential using the optional pulse converter (AK-04/JM-08).  
(Note 2) External dimensions of controllers under 400W that operate models marked with (\*) are that of 400W or more.

\* The number of encoder pulses of actuators that can be operated with SCON-CB is 3,072 pulses for RCS2-SRA7BD/SRGS7BD/SRGD7BD, 1,600 pulses for RCS2-□□5N (incremental), 1,048,576 pulses for DD-□18P: 20 bits, 131,072 pulses for DD-□18S: 17 bits, 2,400 pulses for NS-S□M□ (incremental), 131,072 pulse for ISB (battery-less absolute) and 16,384 pulses for all other models.

Foreword  
 Slider Type  
 Wide Slider Type  
 Rod Type  
 Radial Cylinder  
 Wide Radial Cylinder  
 Table Type  
 Cleanroom Slider  
 Cleanroom Wide Slider  
 Options  
 Reference Data  
 Controller

Less than 400W

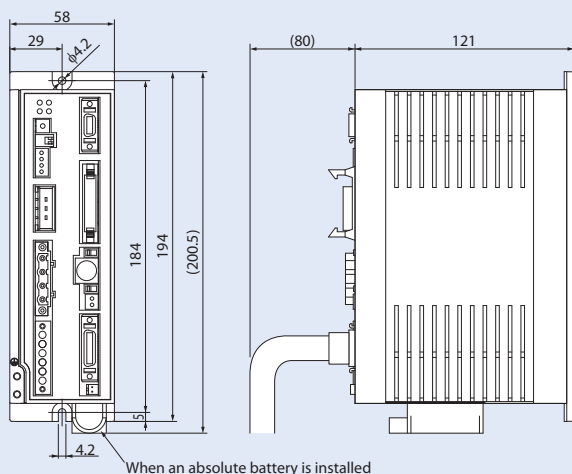

400W or more

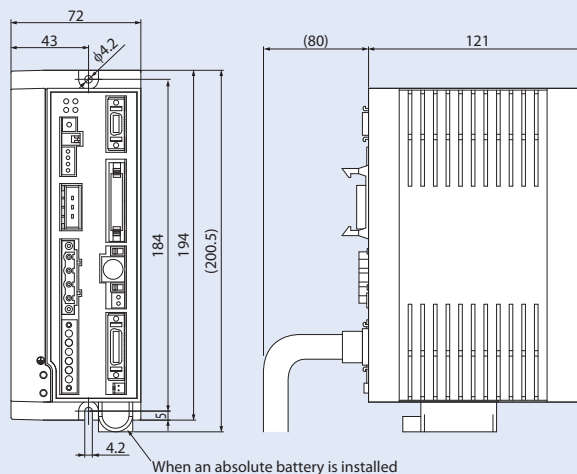

Name of Each Component

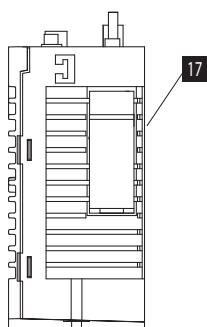
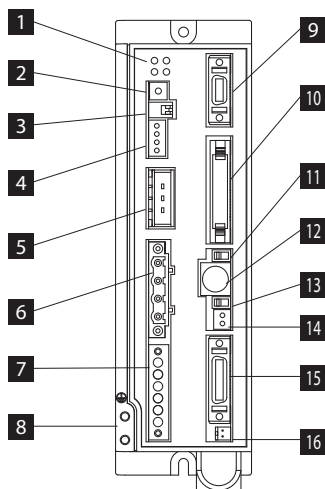

**1** LED display

It represents the state of the controller.

Name	Color	Description
PWR	Green	Lights up on system-ready (after the power is turned on, in normal CPU)
SV	Green	Lights up on servo-on
ALM	Orange	Lights up on alarm
EMG	Red	Lights up on emergency stop

**2** Rotary switch

Used to set up the controller address after connecting the controller in order to identify every controller connected.

**3** Piano switch

Switch for the controller system.

Name	Description
1	Press-operation mode selection switch OFF: Positioner mode, ON: Pulse train control mode * Enabled at power on.
2	Used by the manufacturer for adjustment. Always keep this switch OFF.

**4** System I/O connector

Connector for emergency stop switch, etc.

**5** Regenerative resistance unit cable connector

Resistance unit connector for absorbing regenerative current that occurs when the actuator decelerates to a stop.

**6** Motor connector

Connector for motor cable of actuator.

**7** Power supply connector

Connector for the AC power supply. It has divided inputs on the control power supply side and motor power supply side.

**8** Ground terminal

Screw for protective grounding. Be sure to ground.

**9** Pulse train control connector

Connector used when operating in pulse train control mode. Feedback pulses are also enabled in positioner mode.

**10** PIO connector

Cable connector for performing parallel communication with peripheral devices such as PLC.

**11** Operation mode selection switch

Name	Description
MANU	Does not accept commands from PIO.
AUTO	Ready to accept commands from PIO.

\* The emergency stop switch on the teaching pendant is enabled when the connection is made, regardless of the states, AUTO or MANU. Be sure to turn OFF the power when disconnecting the teaching pendant and SIO communication cable.

**12** SIO connector

Connector for teaching pendant or PC communication cable.

**13** Brake release switch

Used to forcibly release the electromagnetic brake installed in the actuator.

\* To release the brake, the power supply (24VDC) for driving brake must be connected.

**14** Brake power supply connector

Brake power 24VDC supply connector (required only when a brake-equipped actuator is connected).

**15** Encoder/sensor connector

Connector for encoder/sensor cable.

**16** Connector for the absolute data backup battery

Absolute data backup battery connector (required only for the absolute encoder specifications).

**17** Absolute battery holder

Battery holder for installing the absolute data backup battery.



## Touch panel teaching pendant

■ **Features** A teaching device equipped with functions such as position teaching, trial operation, and monitoring.

■ **Model** **TB-02-C**

■ **Configuration**

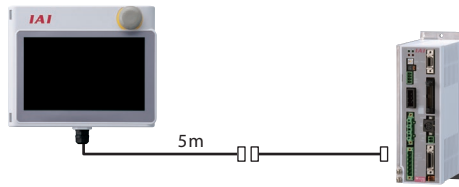

### Specifications

Rated voltage	24V DC
Power consumption	3.6W or less (150mA or less)
Ambient operating temperature	0 to 40°C
Ambient operating humidity	20~85% RH (Non-condensing)
Environmental resistance	IP20
Mass	470g (TB-02 unit only)

## PC software (Windows only)

■ **Features** The start-up support software which comes equipped with functions such as position teaching, trial operation, and monitoring. A complete range of functions needed for making adjustments contributes to shortened start-up time.

■ **Model** **RCM-101-MW** (with an external device communication cable + RS232 conversion unit)

■ **Configuration**

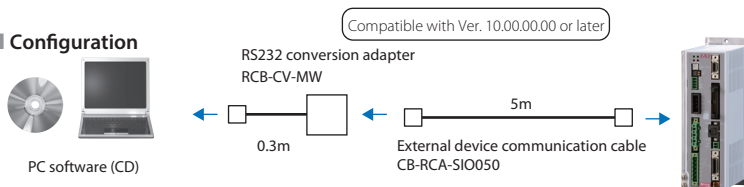

■ **Model** **RCM-101-USB** (with an external device communication cable + USB conversion adapter + USB cable)

■ **Configuration**

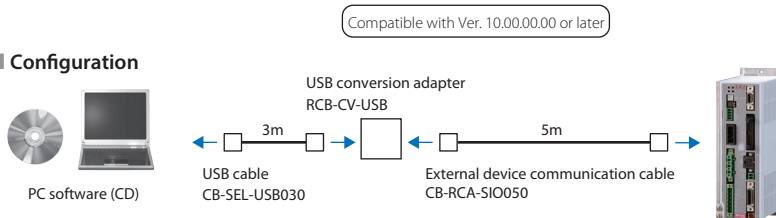

XP SP2 or later / Vista / 7 / 8



## Regenerative resistance unit

■ **Features** Unit that converts the regenerative current generated in motor deceleration to heat. Check the total W of the actuator to be operated in the table below, and prepare one if regenerative resistance is required.

■ **Model** **RESU-2** (standard specification)/**RESUD-2** (DIN rail mounting specification)

■ **Specifications**

Model	RESU-2	RESUD-2
Unit weight	About 0.4kg	
Built-in regenerative resistance value	235Ω 80W	
Unit mounting method	Screw mount	DIN rail mount
Attached cable	CB-SC-REU010	

■ **Necessary Amount Guideline**

	Horizontal	Vertical
0	~100W	~100W
1	~400W	~400W
2	~750W	~750W

\* Depending on the operating conditions, a regeneration resistance higher than that mentioned above may be necessary.

\* The measure of linear servo actuator is in the table above. However, one unit is required for the LSA/LSAS-N105 type.

■ **Necessary Amount Guideline (RCS2-RA13R)**

	Lead 2.5	Lead 1.25
Horizontal	1	0
Vertical	1	1

\* Depending on the operating conditions, a regeneration resistance higher than that mentioned above may be necessary.

■ **Necessary Amount Guideline (DD)**

Series	Type	Required number
DD	LT18□	1
DDA	LH18□	2

■ **External Dimensions**

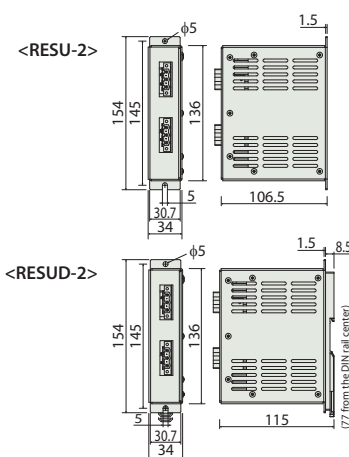

\* If two regenerative units are required, please prepare RESU-2 and RESU-1 (Consult IAI America for more information).

## Absolute data storage battery

■ **Features** Absolute data storage battery for operating an actuator of the absolute specification.

■ **Model** **AB-5 (battery)**  
**AB-5-CS (with case)**



## Dummy plug

■ **Features** This is required when the safety category specification (SCON-CGB) is used.

■ **Model** **DP-5**



When placing an order for a replacement cable, please use the model name shown below.

■ Cable Compatibility Chart

Model name		Motor cable	Motor robot cable	Encoder cable	Encoder robot cable
①	RCS2(CR/W) RCS3(CR) Models other than ② ~ ④	CB-RCC-MA□□□□	CB-RCC-MA□□□□-RB	CB-RCS2-PA□□□□	CB-X3-PA□□□□
②	RCS3 CTZ5C CT8C RCS4(CR)			-	CB-X1-PA□□□□
③	RCS2**	RT	CB-RCC-MA□□□□-RB	CB-RCS2-PLA□□□□	CB-X2-PLA□□□□
④		RA13R(Standard)	CB-RCC-MA□□□□-RB	CB-RCS2-PLA□□□□	CB-X2-PLA□□□□
⑤		RA13R (With brake)		CB-RCS2-PLA□□□□ * CB-RCS2-PLA□□□□ between the controller and brake	CB-X2-PLA□□□□ * CB-X2-PLA□□□□ between the controller and brake
⑥	Without LS	-	CB-X-MA□□□□	-	CB-X3-PA□□□□
⑦	With LS	-		-	CB-X2-PLA□□□□
⑧	LSA	S/H/L/N	-	-	CB-X3-PA□□□□
⑨		W	-	CB-XMC-MA□□□□	-
⑩	DD/DDA DDCR/DDACR DDW	LT18□	-	-	CB-X3-PA□□□□
⑪		LH18□	-	CB-XMC-MA□□□□	-
⑫	DDA DDACR (With brake)	LT18	-	-	CB-X3-PA□□□□ CB-DDB-BK□□□□ between brake box and actuator
⑬	LH18	-	CB-XMC-MA□□□□	-	CB-X3-PA□□□□ CB-DDB-BK□□□□ between brake box and actuator
⑭	IS(P)WA	S/M/L	-	-	CB-X1-PA□□□□-WC
⑮	Models other than ① ~ ⑫	-	CB-X-MA□□□□	-	CB-X1-PA□□□□ (for 20m or less) *
⑯		Models other than ① ~ ⑫ LS specification		-	-
⑰	Models other than ① ~ ⑫ LS specification	-	-	-	CB-X1-PLA□□□□ (for 20m or less) *
⑱	Models other than ① ~ ⑫ LS specification	-	-	-	CB-X1-PLA□□□□-AWG24 (For 21m or more)

\* Those that do not have the battery-less absolute specification will also be CB-X1-PA□□□□/CB-X1-PLA□□□□ for 20m or more.  
\*\* For the RCS2-RA13R load cell specification cables, please contact IAI America.

Model name	PIO flat cable	Pulse train control cable	
⑲	SCON-CB	CB-PAC-PIO□□□□	CB-SC-PIOS□□□□

Model Name **CB-RCC-MA□□□□/CB-RCC-MA□□□□-RB**

\* Please indicate the cable length (L) in □□□□, (e.g. 080 = 8m), maximum 30m

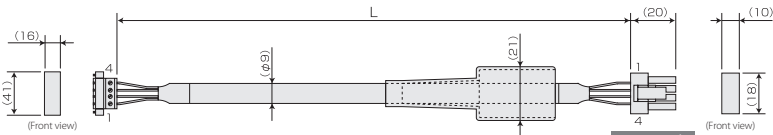

Minimum bending radius  $r = 51\text{mm}$  or more (Dynamic bending condition)  
\* Please use the robot cable if the cable needs to be installed through the cable track

Wiring	Color	Signal	1	2	3	4	Signal	Color	Wiring
0.75sq	Green	PE	1	2	3	4	1	U	Red
	Red	U	2	3	4	1	2	V	White
	White	V	3	4	1	2	3	W	Black (Crimped)
	Black	W	4	1	2	3	4	PE	Green

Model Name **CB-XMC-MA□□□□**

\* Please indicate the cable length (L) in □□□□, (e.g. 080 = 8m), SCON/SSEL: 20m, XSEL: 30m

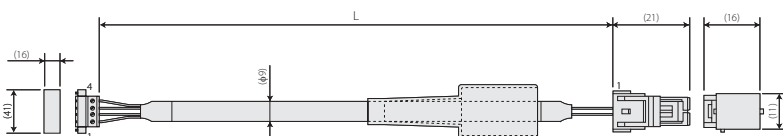

Minimum bending radius  $r = 55\text{mm}$  or more (Dynamic bending condition)  
\* Only the robot cable is available for this model.

Wiring	Color	Signal	1	2	3	4	Signal	Color	Wiring
1.25sq	Green	PE	1	2	3	4	1	U	Red
	Red	U	2	3	4	1	2	V	White
	White	V	3	4	1	2	3	W	Black (Crimped)
	Black	W	4	1	2	3	4	PE	Green

Model Name **CB-RCS2-PA** (for RCS2/RCS3) / **CB-X3-PA** (for NS/RCS2/RCS3)

\* Please indicate the cable length (L) in □□□, (e.g. 080 = 8m), maximum 30m

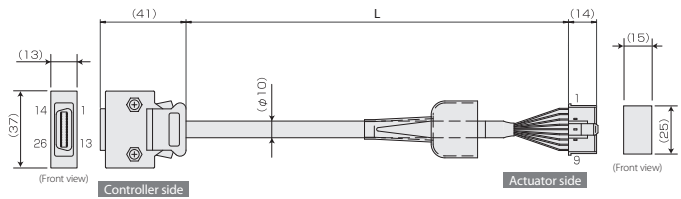

Minimum bending radius  $r = 58\text{mm}$  or more (Dynamic bending condition)  
\* Please use the robot cable if the cable needs to be installed through the cable track.

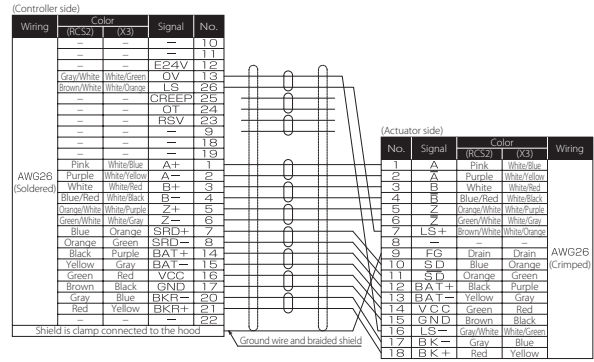

Model Name **CB-X-MA**

\* Please indicate the cable length (L) in □□□, (e.g. 080 = 8m), maximum 30m

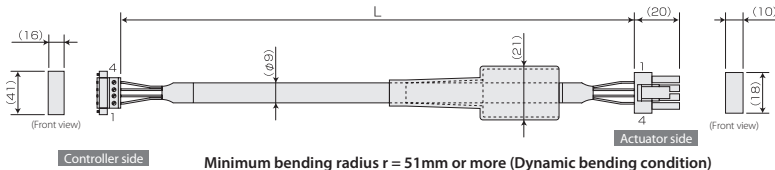

Minimum bending radius  $r = 51\text{mm}$  or more (Dynamic bending condition)  
\* Only the robot cable is available for this model.

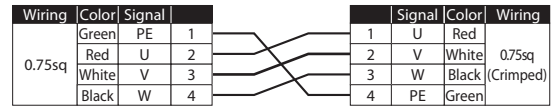

Model Name **CB-X1-PA**

\* Please indicate the cable length (L) in □□□, (e.g. 080 = 8m), maximum 30m

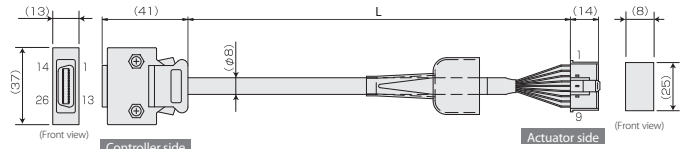

Minimum bending radius  $r = 44\text{mm}$  or more (Dynamic bending condition)  
\* Only the robot cable is available for this model.  
\* If you require ISB/ISDB/ISDBCR (encoder type is battery-less absolute) with the cable of 21m or more, select the CB-X1-PA-□□□-AWG24.

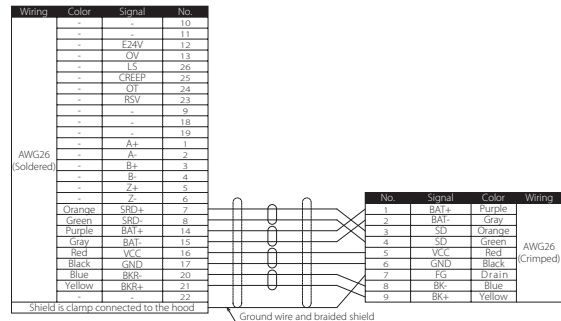

Model Name **CB-X1-PA-□□□-AWG24**

\* Please indicate the cable length (L) in □□□, (e.g. 210 = 21m), maximum 30m

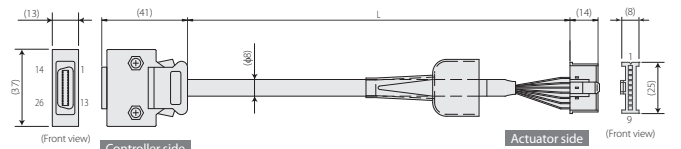

Minimum bending radius  $r = 44\text{mm}$  or more (Dynamic bending condition)  
\* Only the robot cable is available for this model.

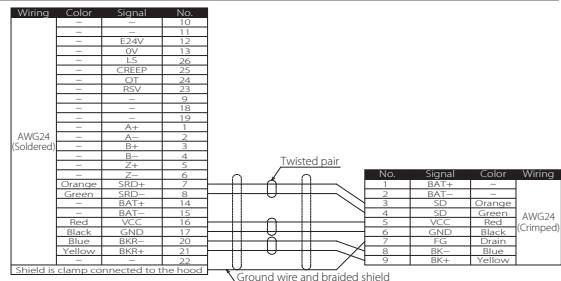

Model Name **CB-X1-PLA**

\* Please indicate the cable length (L) in □□□, (e.g. 080 = 8m), maximum 30m

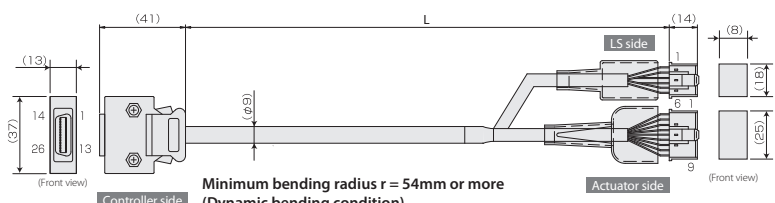

Minimum bending radius  $r = 54\text{mm}$  or more (Dynamic bending condition)  
\* Only the robot cable is available for this model.  
\* If you require ISB/ISDB/ISDBCR (encoder type is battery-less absolute) with the cable of 21m or more, select the CB-X1-PLA-□□□-AWG24.

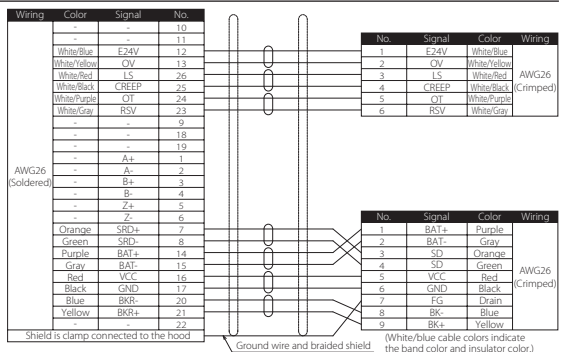

When placing an order for a replacement cable, please use the model name shown below.

Model Name **CB-RCS2-PLA**□□□ (for RCS2 rotary)/**CB-X2-PLA**□□□ (NS LS specification/for RCS2 rotary)

\* Please indicate the cable length (L) in □□□, (e.g. 080 = 8m), maximum 30m

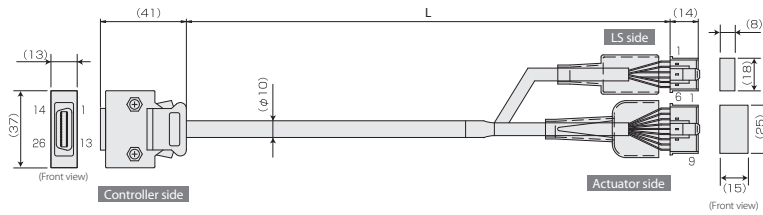

Minimum bending radius  $r = 58\text{mm}$  or more (Dynamic bending condition)  
 \* Please use the robot cable if the cable needs to be installed through the cable track.

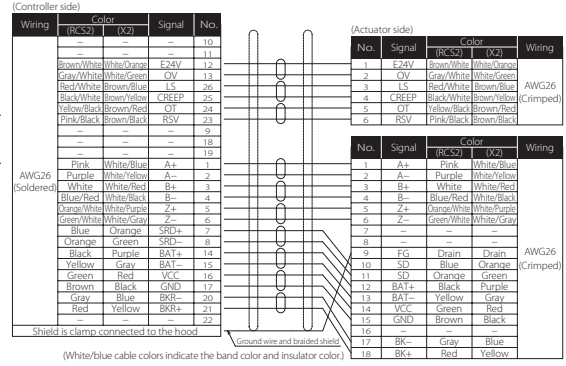

\* The above is the wiring diagram of encoder cables. For the wiring diagram of encoder robot cables, please contact IA.

Model Name **CB-X1-PLA**□□□-AWG24

\* Please indicate the cable length (L) in □□□, (e.g. 210 = 21m), maximum 30m

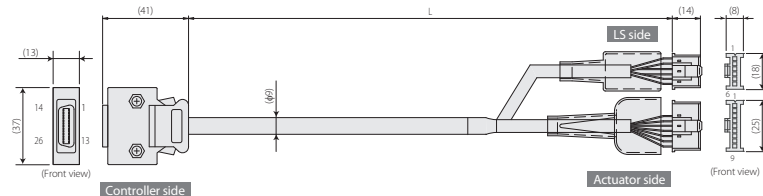

Minimum bending radius  $r = 54\text{mm}$  or more (Dynamic bending condition)  
 \* Only the robot cable is available for this model.

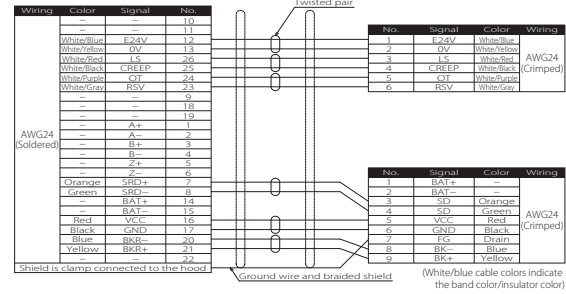

Model Name **CB-XEU-MA**□□□

\* Please indicate the cable length (L) in □□□, (e.g. 080 = 8m), maximum 30m

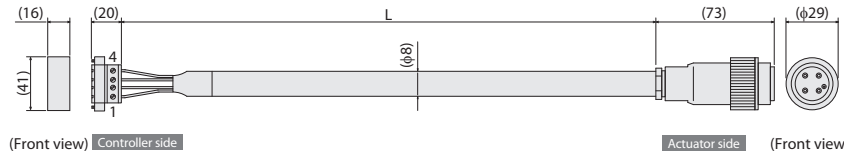

Minimum bending radius  $r = 48\text{mm}$  or more (Dynamic bending condition)  
 \* Only the robot cable is available for this model.

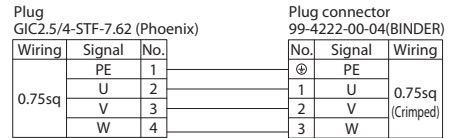

Model Name **CB-X1-PA**□□□-WC

\* Please indicate the cable length (L) in □□□, (e.g. 080 = 8m), maximum 30m

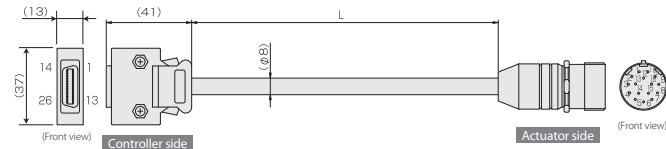

Minimum bending radius  $r = 44\text{mm}$  or more (Dynamic bending condition)  
 \* Only the robot cable is available for this model.

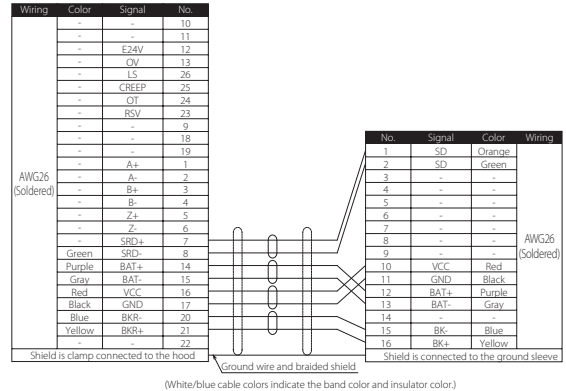

Model Name **CB-PAC-PIO** □ □ □

\* Please indicate the cable length (L) in □ □ □, (e.g. 080 = 8m), maximum 10m

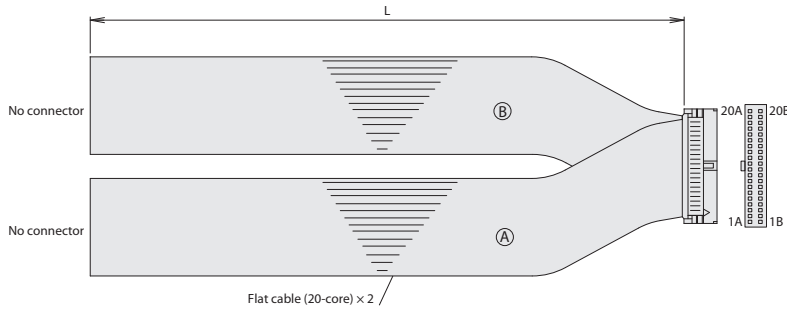

HIF6-40D-1.27R

No.	Signal Name	Cable Color	Wiring	No.	Signal Name	Cable Color	Wiring
1A	24V	Brown-1	Flat cable® (pressure-welded)	1B	OUT0	Brown-3	Flat cable® (pressure-welded) AWG28
2A	24V	Red-1		2B	OUT1	Red-3	
3A	-	Orange-1		3B	OUT2	Orange-3	
4A	-	Yellow-1		4B	OUT3	Yellow-3	
5A	IN0	Green-1		5B	OUT4	Green-3	
6A	IN1	Blue-1		6B	OUT5	Blue-3	
7A	IN2	Purple-1		7B	OUT6	Purple-3	
8A	IN3	Gray-1		8B	OUT7	Gray-3	
9A	IN4	White-1		9B	OUT8	White-3	
10A	IN5	Black-1		10B	OUT9	Black-3	
11A	IN6	Brown-2		11B	OUT10	Brown-4	
12A	IN7	Red-2		12B	OUT11	Red-4	
13A	IN8	Orange-2		13B	OUT12	Orange-4	
14A	IN9	Yellow-2		14B	OUT13	Yellow-4	
15A	IN10	Green-2		15B	OUT14	Green-4	
16A	IN11	Blue-2		16B	OUT15	Blue-4	
17A	IN12	Purple-2		17B	-	Purple-4	
18A	IN13	Gray-2		18B	-	Gray-4	
19A	IN14	White-2		19B	OV	White-4	
20A	IN15	Black-2		20B	OV	Black-4	

Model Name **CB-SC-PIOS** □ □ □

\* Please indicate the cable length (L) in □ □ □, (e.g. 080 = 8m), maximum 10m

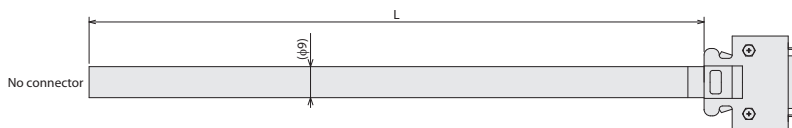

Color	Wiring	Color	Signal No.
Black	Black	Not used	1
White/Black	White/Black	Not used	2
Red	Red	PP	3
White/Red	White/Red	/ PP	4
Green	Green	NP	5
White/Green	White/Green	/ NP	6
Yellow	Yellow	AFB	7
White/Yellow	White/Yellow	/ AFB	8
Brown	Brown	BFB	9
White/Brown	White/Brown	/ BFB	10
Blue	Blue	ZFB	11
White/Blue	White/Blue	/ ZFB	12
Gray	Gray	GND	13
White/Gray	White/Gray	GND	14

Shield  
The shield is connected to the cable clamp

Model Name **CB-DDB-BK** □ □ □

\* Please indicate the cable length (L) in □ □ □, (e.g. 080 = 8m), maximum 20m

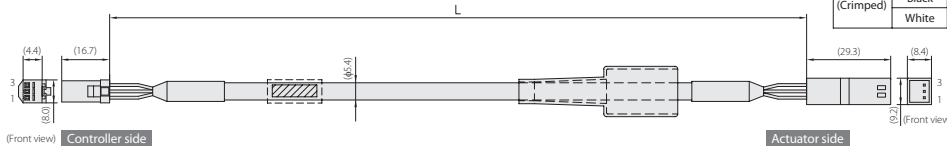

J11SF-03V-KX

Wiring	Color	Signal	No.
AWG20 (Crimped)	Red	+	3
	Black	-	2
	White	FG	1

J11SFM-03V-KX

No.	Signal	Color	Wiring
3	+	Red	AWG20 (Crimped)
2	-	Black	
1	FG	White	

Foreword  
Slider Type  
Wide Slider Type  
Rod Type  
Radial Cylinder  
Wide Radial Cylinder  
Table Type  
Cleanroom Slider  
Cleanroom Wide Slider  
Options  
Reference Data  
Controller

---

## **IAI America, Inc.**

**US Headquarters:** 2690 W. 237th Street, Torrance, CA 90505 (800) 736-1712

**Chicago Office:** 110 E. State Pkwy, Schaumburg, IL 60173 (800) 944-0333

**Atlanta Office:** 1220 Kennestone Circle, Suite 108, Marietta, GA 30066 (888) 354-9470

**[www.intelligentactuator.com](http://www.intelligentactuator.com)**

The information contained in this product brochure may change without prior notice due to product improvements.

## **IAI Industrieroboter GmbH**

Ober der Röth 4, D-65824 Schwalbach am Taunus, Germany

## **IAI (Shanghai) Co., Ltd.**

Shanghai Jiahua Business Center A8-303, 808,  
Hongqiao Rd., Shanghai 200030, China

## **IAI Robot (Thailand) Co., Ltd.**

825 Phairokijja Tower 7th Floor, Bangna-Trad RD.,  
Bangna, Bangna, Bangkok 10260, Thailand